

HUUVAN

Creating Clean, Protecting Health

HV200-ACS(C35/Z2-22)

INDUSTRIAL VACUUMS

USER AND MAINTENANCE BOOK



ATEX directive

ECC/94/09 directive (compulsory since July 1st 2003) regulate the constructive and safety characteristics to be respected in the installation and use of appliances in every environment in which a potentially explosive atmosphere could be generated. All the equipment assigned to be used on potentially explosive atmosphere generated by gas or dust, must be in keeping with ATEX regulations. ECC/99/92 regulations (compulsory since July 1st 2006) compel companies to classify all zones showing potential risks of explosion, dividing all environment where explosive atmosphere could be generated in CLASSIFIED ZONES.

Note: safe use ATEX

The following notes, are an integration of normal notes of use and maintenance. These safety prescriptions are compulsory and always must be completely respected, in case of violation of these prescriptions the producer declines every legal responsibility. In the case of ambiguity between some points of the two handbooks (ATEX and User manual), the present document must have priority.

ATEX record mark

Before buying or operating with vacuum cleaner verify that technical data on the plate label of the appliance are correct for the classified zone in which vacuum cleaner will operate. With the record mark - **II 3D T135°C IP 65** – vacuum cleaner can be used in a classified zone 22. **Every use of the equipment in zones with classification different than the admitted one is forbidden; if this happens Huuvan declines every responsibility.** The equipment is planned to work in classified zone Atex 22, with the potentially explosive dust presence, but the appliance is not classified for the inner parts of the appliance itself.

Electrical connection

Before operation check if the data on the plate (Voltage, Frequency) of the vac are compatible to those of the current network. Check if the sense of rotation of the turbine is correct as written at of the user manual. Always check the sense of rotation in a not-classified zone, moreover the machine should not have dust

Do not change the sense of rotation of turbine in a classified zone.

Before starting operation verify that the earth connection of the system is in compliance with the electrical norms, never start the vacuum cleaner if unprovided of grounding; in case of violation of such prescriptions Huuvan declines legal responsibility.

Additional safety regulations

In order to assure and to preserve the safety of vacuum cleaner, it's compulsory to follow the below rules:

- Never open the appliance in a classified zone.
- It is not allowed to change or to substitute any primary or secondary component installed on the equipment, neither to change the electrical connections.
- Verify periodically the filtering system, if filter seems to be damaged it's compulsory to stop operation and proceed with the maintenance of the filter.
- All maintenance operations (filter cleaning or tank emptying) must be performed with the appliance switched off, disconnected from the power network and in non-classified zone.
- If the phases of power network are inverted (vacuum cleaner blows instead of vacuuming) immediately stop the operation, switch off the appliance and disconnect it from the power network, provide for phases inversion. Never invert the phases of the vacuum cleaner in a classified zone.
- Do not remove the ground strip, verify periodically the wear and tear on the strip; if rubber strip does not touch earth stop immediately the use and ask for correct spare and authorisation to change it.
- Use only adapt accessories, supplied by the producer and suitable for ATEX applications zone 22; every use of non authorised accessories will decay Huuvan responsibility.
- The simple dismantling of whichever electrical or mechanical component compromises the safety of the appliance; in case of dismantling of whichever component the producer declines all responsibilities.
- Schedule maintenance every year by qualified and authorized by Huuvan personnel. Such a prescription is not compulsory, but warmly suggested. In any case a review total of the equipment must be carried on every two years by a technician authorized by Huuvan.
- If whichever problem occurs, suspend the use of the appliance and ask for a complete technical check by authorised personnel.

01. INTRODUCTION

This use and maintenance manual will set out the guidelines and procedures that must be followed by all those operating this equipment in order to guarantee:

- Operators' safety
- Correct use of the machine
- Optimum performance



IT IS NECESSARY THAT THE AUTHORISED PERSONNEL AND MACHINE OPERATOR HAVE READ AND UNDERSTOOD THE MANUAL BEFORE USING THE VACUUM CLEANER.

Due to the importance of this information, we recommend that the operator:

- Always keeps this manual close at hand for easy consultation
- Keeps the manual in a safe place in order to prevent loss or damage
- Asks the manufacturer/supplier for a replacement copy in case of loss or damage
- Supplies this manual and the manufacturer's details together with the machine if it is sold to a third party.



N.B. IF THE PURCHASED VACUUM CLEANER IS ATEX RATED, THE TECHNICAL PLATE ATTACHED TO THE ENGINE HAS A SERIAL NUMBER THAT IS USED FOR REQUESTING A COPY OF THE CERTIFICATE IF THIS IS DETERIORATED OR LOST.

The manufacturer reserves the right to update its products and manuals and is not required to provide updated versions of them.

02. WARRANTY

The vacuum cleaners manufactured for Huuvan have been fully inspected to guarantee correct electrical, pneumatic and mechanical function. The vacuum cleaners are covered by a 12-month warranty from date of delivery. All defective parts of the machine are covered by warranty but this does not include parts damaged during shipping, handling or use nor does it cover parts damaged by normal wear and tear.

Repairs can be carried out by an authorised service centre or directly by a Huuvan service engineer.

To request your warranty service you **MUST** send a written request to the dealer or directly to the manufacturer including the manufacturing details that can be found on a plate fitted inside your machine together with a copy of the invoice or proof of purchase.

The warranty is invalid under the following conditions:

- Improper use of the machine or total or partial failure to comply with the contents of this manual
- Any part of the vacuum cleaner is altered or modified in any way
- Incorrect electrical installation
- If the laws in the country of use are not respected
- Inadequate maintenance
- The machine has not undergone routine maintenance as specified in this manual
- Use of spare parts that are not produced by Huuvan or not specifically indicated for the model in use
- Partial or total failure to comply with the instructions given in this manual

03. UNINTENDED USE

- Never suck up cigarette butts that have not been properly put out and/or any other flammable materials
- Never suck up substances that may explode in contact with the air
- Never operate in environments where explosive gases and/or gases from toxic chemical products are present in the air
- Check the suitability of the cartridge filter before sucking up toxic substances
- Disconnect from the power outlet before accessing any electrical components of the machine
- Do not modify the machine in any way
- Do not use the machine in a way that does not comply with the requirements of this manual

04. MACHINE DATA

4.1 TECHNICAL DATA PLATE

Every Huuvan machine carries a registration plate showing essential details that are necessary when contacting the supplier/manufacturer for advice, suggestions or information on spare parts. The following details are included on the plate:

- Manufacturer
- Model
- Supply voltage
- Installed rated power
- CE symbol (built in compliance with Machinery Directive 2006/42/EEC)

4.2 TESTING

All Huuvan machines are tested before packaging and delivery in order to ensure the correct function of each component. An accurate electrical safety test is carried out in compliance with specific electric safety standards related to:

- Ground continuity test
- Insulation resistance test between every phase and the ground
- Dielectric test
- Measurement of dispersed current
- Measurement of power and absorbed current (acceptable difference of +/-10% of rated value)
- Measurement of maximum depression and air exhaust values (tolerance of +/-15% based on temperature values and humidity of environment)
- Measurement of maximum air absorption

4.3 SAFETY DEVICE

The vacuum cleaner has been manufactured in compliance with all legal standards for the operator's safety.

- All metal components are grounded to eliminate shock or electrostatic discharge, including the flexible suction hose that is properly grounded. also in this regard the choice of a suitable flexible suction hose allows to eliminate this risk on the hose length that goes from the use area to the vacuum cleaner.
- The brakes fitted onto the anterior pivoting castors safely fix the machine in its place of use where there may be a risk of movement due to uneven floor surfaces or other particular working conditions.



BEFORE USING THE MACHINE CHECK THAT THE MACHINE HAS NOT SUFFERED ANY SHOCKS OR DAMAGES DURING THE TRANSPORT THAT CAN AFFECT THE OPERATION OF THE VACUUM CLEANER

05. PERFORMANCE TOLERANCES

The performance of the motor may vary by 15% based on the temperature and air humidity.
The safety valves are calibrated based on the amperage of the motor.

06. SAFETY PROVISIONS

- Carefully read the instructions in this manual before starting, using, servicing or operating the vacuum cleaner
- Check that the vacuum cleaner hasn't been damaged in any way
- Never turn on the machine if it is faulty or if you suspect it is faulty
- Check that the switch isn't worn or damaged
- Do not approach the suction intake of the machine with unfastened or broken garments that could easily be sucked into the machine
- Check that the filters are present and efficient
- Make sure that the filters are installed correctly and in full working order, always observing the regulations in force in the workplace
- Do not carry out repairs without the manufacturer's authorisation
- Never use gasoline, solvents or other flammable liquids for cleaning; only proper detergents should be used for cleaning
- Never move the machine by pulling the power cable or flexible hose
- Never direct the opening of the machine or the flexible tube towards people or animals
- Protect the machine from the rain
- Check that the machine is connected to a power source with the correct voltage indicated on the registration plate
- Make sure that the power cable has no wear or damage. if replacing the cable, always replace it with another of the same specifications as the original one: cables that are not approved or of inferior quality may overheat and cause serious injury to the user
- Make sure that the machine is connected to an appropriate power source in full working order (check the presence of a fully functional grounding socket)
- Repairs must only be carried out by authorised personnel and only when the machine is turned off and disconnected from the power source
- Never allow unauthorised personnel to use the machine
- Make sure that all safety devices are in full working order before turning on the machine
- Never cover the vacuum cleaner during use

07. INSTALLATION

7.1 DELIVERY AND HANDLING

All machines are carefully tested and checked by a Huuvan service engineer before delivery. The machine is transported in a protective film that allows the courier to see the item during transport and is securely fixed to a pallet. If any part of the machine is not intact or has been damaged during transport, fill in an immediate complaint with the courier. Parts that have been damaged or broken due to incorrect transport or handling of the machine will not be recognised by the manufacturer's warranty. The machine must be lifted and moved using a forklift truck in accordance with the relevant safety regulations in force in the workplace.

7.2 CHECK THE PROPER ELECTRICAL CONNECTION

Connect the industrial plug to the power cable and connect the plug to a socket that has the same amp rating and is protected by a line-isolating switch; in the case of the three-phase vacuum cleaner, it is necessary to check before use that the motor rotates in the correct direction (clockwise) as shown by the die-cast indicator on the turbine; if rotation occurs in an anti-clockwise direction, it is necessary to disconnect the machine from the power source, invert one of the three phase cables inside the plug and check again for correct rotation.

08. PERIODICAL MAINTENANCE

Maintenance and cleaning operations on the vacuum cleaner must ALWAYS be carried out when the vacuum is turned off and disconnected from the power source. No particular measures must be taken for the maintenance, cleaning or lubrication of the suction unit. However, it is important to remember that correct use and servicing are essential if the safety and efficiency of the vacuum are to be guaranteed.

To ensure regular and constant operation and to prevent the warranty from becoming void, always use genuine Huuvan spare parts when repairs are needed.

8.1 BEFORE TURNING ON AND TURNING OFF EVERY DAY

- Visually check that the suction hose has not been damaged in any way (it must not be damaged, torn, crushed)
- Check that the electrical switches are in full working order and are not damaged in any way
- Check the level of waste inside the main barrel N.B. Empty the main barrel if you are using an ATEX model empty the main barrel
- Check that the suction hose has not been damaged in any way
- Check that the motor head is correctly positioned on the filter chamber and that the latter is correctly placed on the main barrel
- If the vacuum cleaner is moved, ensure that the power voltage of the play in this new location corresponds to the one on the technical data plate

8.2 AT EVERY 200 HOURS OF OPERATION

- Check the condition of the primary filter: it must not have tears, holes or other damage: in this case replace it (see 14.)
- Check that the technical data plate is legible and not damaged in any way: contact the manufacturer for a replacement if necessary.



N.B. PERFORM THE FOLLOWING OPERATIONS AT EVERY 10 HOURS OF OPERATION IF THE VACUUM CLEANER IS AN ATEX MODEL

09. PRODUCT DISPOSAL

Dispose of the machine and any accessories according to the legislation of the country. To avoid affecting the environment or your health or of others, it is recommended to separate the machine from other waste, and if necessary properly recycle it.

10. TECHNICAL DATA



| Model | HV200-ACS (C35/Z2-22) | HV200-ACS (C35/Z2-22) |
|---|---|---|
| Code | HV200-ACS (C35/Z2-22) 230 V – 50 Hz | HV200-ACS (C35/Z2-22) 400 V – 50 Hz |
| Certificate | CE | CE |
| Motors | Turbine | Turbine |
| Power | 2 kW | 2,6 kW |
| Voltage | 230 V – 50 Hz | 400 V – 50 Hz |
| Filter cleaning | Automatic | Automatic |
| Filtration Class | HEPA | HEPA |
| Air flow rate | 320 m3/h | 320 m3/h |
| Depression | 300 mBar | 320 mBar |
| Useful capacity | 50 L | 50 L |
| Dimensions | 80x60x148 cm | 80x60x148 cm |
| Inlet dimension | 50 mm | 50 mm |
| Tank diameter | 460 mm | 460 mm |
| Weight | 105 Kg | 105 Kg |
| Sound pressure level (ISO 11201) | < 78 | < 78 |

11. DESCRIPTION



1 – Suction Unit

2 – ON - OFF switch

3 – Filter cleaning button

4 – Accessories connection

5 – Wheels with brake

6 – Tank Release

7 – Air exhaust

8 – System clean filter

12. MOUNTING OF PARTS

Depending on the specific needs of the client, the vacuum cleaner may include accessories that are not normally supplied in the standard version. It is necessary to select the suction hose and accessories that are appropriate for the type of material that must be sucked into the cleaner.
The machine is now ready for use.

Connect one end of the flexible hose to the desired accessory and the other with the quick coupling nozzle mounted on the filter chamber. (See the accessories sheet)

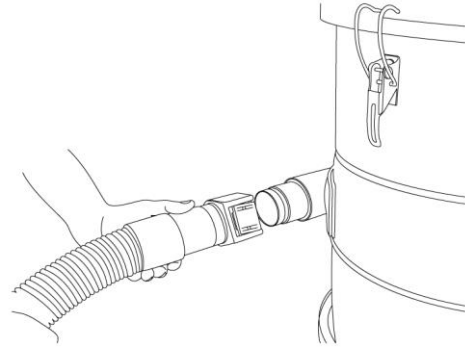

13. USING THE VACUUM CLEANER



Before switching ON the vacuum be sure the container is empty



1. Suction ignition.
2. Suction shutdown.
3. Automatic filter cleaning ignition and shutdown.

Before machine start, check that the switch (3) is in position (I), turned ON.

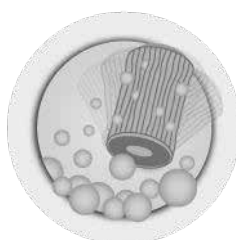

If necessary, it is possible to force the cleaning of filtering system turn off and switch on again (3).
From position 0 to position I

14. FILTER REPLACEMENT



THE SUBSTITUTION OF THE FILTER MUST BE CARRIED ONLY BY AN AUTHORISED HUUVAN SERVICE ENGINEER. EACH NON AUTHORISED SUBSTITUTION AND/OR MAINTENANCE OF FILTERING SYSTEM CAN COMPROMISE THE SAFETY OF APPLIANCE, IN THIS CASE THE PRODUCER DECLINES EVERY RESPONSIBILITY.

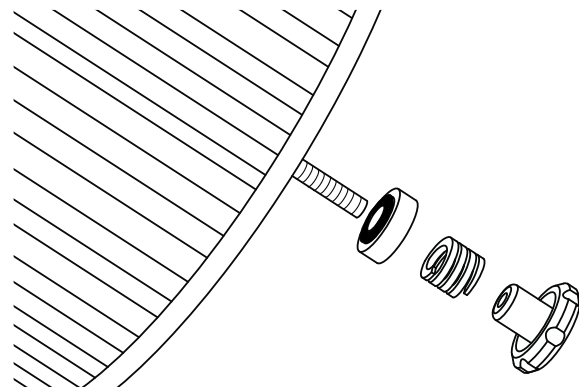
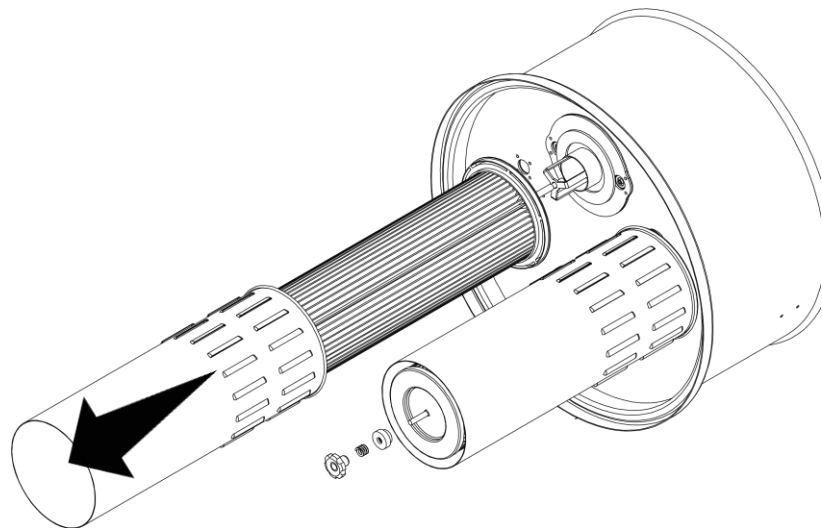

1. Disconnect and lift the head.
2. Remove the filter's cylindrical steel protection (unscrewing the screws on the edge).
3. Unscrew the wing nut and remove the spring and washer.
4. Replace the filter with a proper one for the vacuum cleaner in use
5. Install the new filter according to the label on the bottom of the filter
 - Washer with rubber part facing the base of the filter
 - Spring
 - Plastic wing nut.
6. Mount the cylindrical protection, then reconnect the head on the filtering chamber.



TANK MUST BE EMPTIED EACH TIME THE CLEANING OPERATION IS ENDED; ALWAYS EMPTY THE TANK IN A SAFE AND NON-HAZARDOUS ZONE.

15. EMPTYING THE MAIN COLLECTING BARREL

- 1 - Push the handle upwards and remove the barrel.
- 2 - Empty the barrel.
- 3 - Insert the attachment in "V" in its corresponding seat and slide the bearing on the rail by pushing down on the handle.

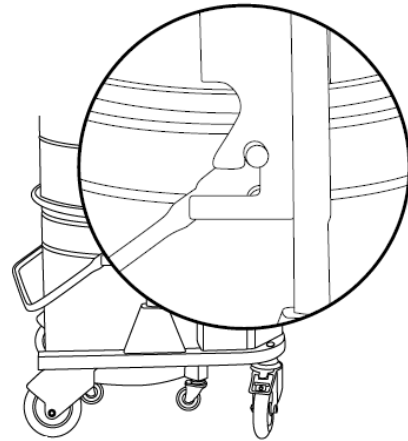

TANK MUST BE EMPTIED EACH TIME THE CLEANING OPERATION IS ENDED; ALWAYS EMPTY THE TANK IN A SAFE AND NON-HAZARDOUS ZONE.

16. TROUBLESHOOTING

You can thus solve any problem that may occur.

Motors do not start. ▶ No electrical voltage. ▶ Check cables, plugs and socket.

Suction capacity decreases slowly. ▶ Filter, nozzle, suction hose or suction pipe may be blocked. ▶ Check, clean accessories. Clean filter.

Dust comes out during the vacuuming. ▶ Filter has not been fastened correctly or is defective. ▶ Check to see if filter is sitting properly; replace if required.

17.1 ELECTRIC DIAGRAM

Electric Triple-Phase Atex Components & Motor Circuit - Wiring Diagram W18

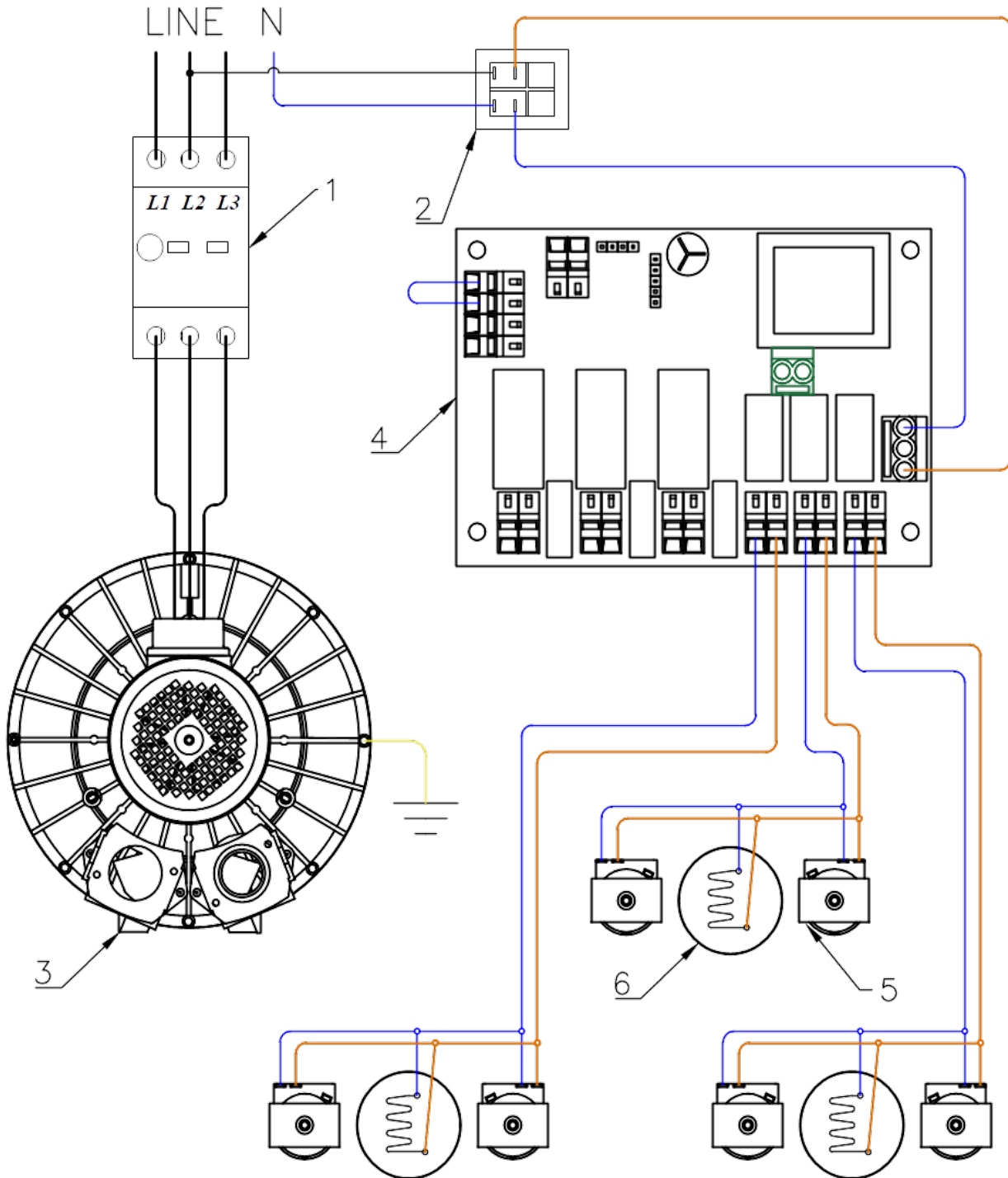

- 1- STARTER
- 2- TOGGLE COMMUTATOR 1-0
- 3- MOTOR
- 4- ELECTRONIC CARD
- 5- VIBRATOR
- 6- SOLENOID

17.2 ELECTRIC DIAGRAM

Electric Single-Phase Atex Components & Motor Circuit - Wiring Diagram W19

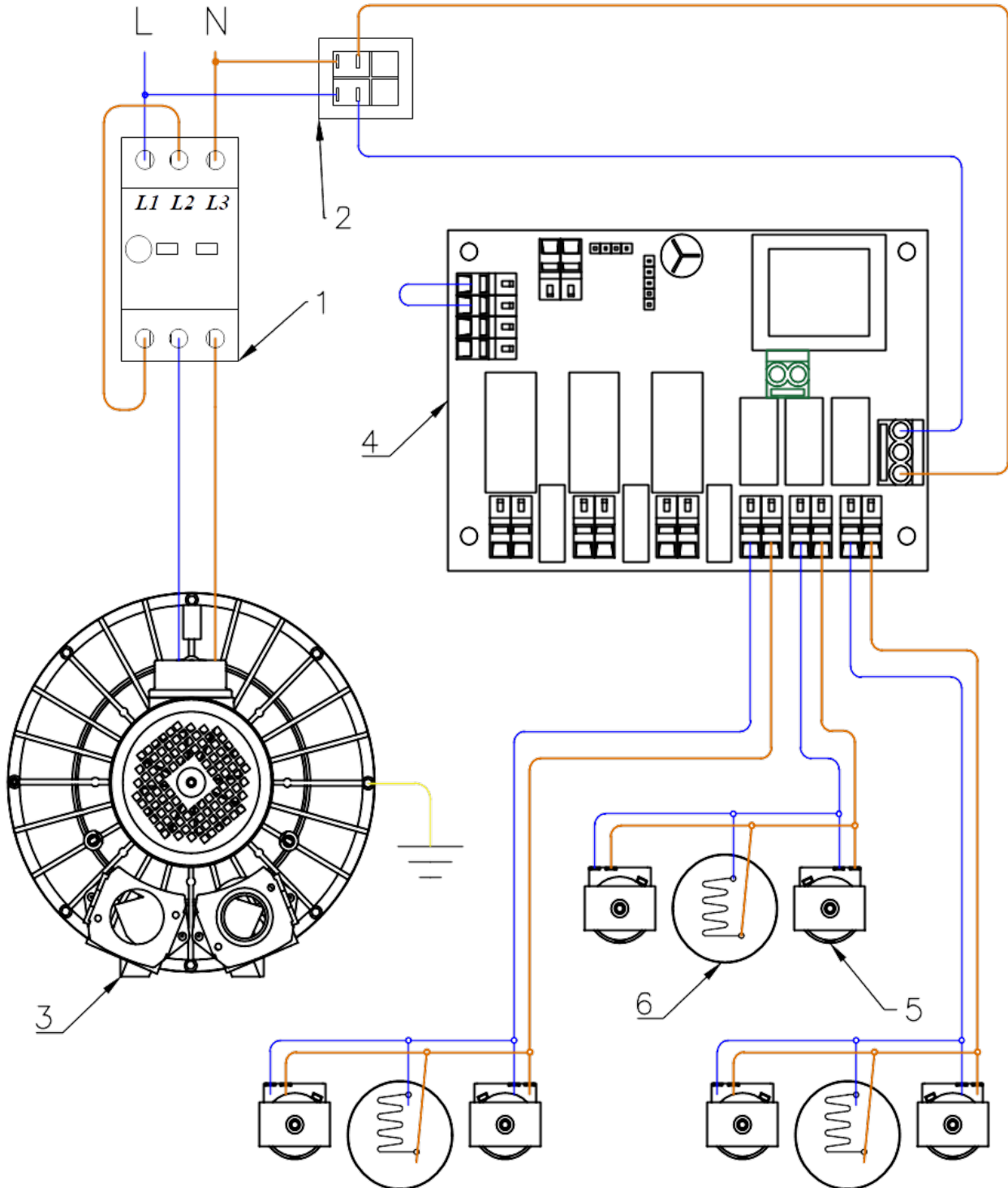

- 1- STARTER
- 2- TOGGLE COMMUTATOR 1-0
- 3- MOTOR
- 4- ELECTRONIC CARD
- 5- VIBRATOR
- 6- SOLENOID

DECLARATION “CE” OF CONFORMITY



ATEX DIRECTIVE 94/9/EC 2014/34/UE

In conformity with European Directive EN 45014

Hereby **DECLARES** under its own responsibility that the model:

| | |
|----------|--|
| MODEL | HV200-ACS (C35/Z2-22) |
| CATEGORY |  II 3GD Ex nA IIB T4 Gc Ex IIIB T 135°C Dc IP65 |

IS FOUND TO COMPLY with the terms of the following **EC directives** and **corresponding Italian laws**

EC Directive:

Machine Directive: **2006/42/EC**

LVD Directive: **2006/95/EC 2014/35/UE**

Electromagnetic Compatibility Directive: **EMC: 2004/18/EC 2014/30/UE**

RoHS Directive: **2011/65/EC**

With the requirements of the following standards:

EN 1127-1 EN 60034-1

EN 13463-1 EN 60034-2

EN 1927 EN 60334-5

EN 12100 EN 60034-6

EN 10011 EN 60034-7

EN 14986 EN 60624-1

EN 50281-1-1-1

This declaration shall become void if any changes are made on the machine or failure to follow instructions contained in the owner's manual.

Riccardo Bettella
Product Specialist

Notes



We supply a full range of cleaning equipment for rental or purchase.

For more information, or a cleaning solution to suit your business, please get in touch –

For a more comprehensive product range, please visit our website.

Distributed by:



Address

Crescent Industrial Ltd
Berrington House,
Berrington Road,
Leamington Spa
CV31 1NB

Contact

t: 0845 33 77 695
f: 0845 33 78 695
e: info@c-ind.co.uk

www.crescentindustrial.co.uk/huuvan/