

TOPFLOOR

SIMPLE, STRONG, SAFE

EX55-0CS

Operator's manual



English

www.crescentindustrial.co.uk

Specifications – Safety - Usage - Maintenance

A copy of these instructions must be made available to everyone involved in putting this machine into use, and its operation, maintenance and servicing!!

Original instructions for use in accordance with Annex 1 (Paragraph 1.7.4.) of the Machinery Directive 2006/42/EC

All rights reserved. No part of this document may be reproduced, stored in a database or retrieval system or published in any form or in any way, electronically, mechanically, by print, photocopy, microfilm or any other means without the prior written permission of Crescent Industrial. This also applies to all accompanying drawings and diagrams. Crescent Industrial shall retain the right to modify machine components at any time with no obligation to inform the purchaser in advance or directly. The contents of this manual may also be subject to change without notice. For information about the machine's settings, maintenance work and repairs that is not provided in this user manual, please contact the supplier's technical services department. This user manual was compiled with the utmost care. Crescent Industrial cannot, however, accept any responsibility for any errors it may contain or the possible consequences thereof.

USER MANUAL EX35-OCS

TABLE OF CONTENTS

ADDRESSES	04
FOREWORD	04
1. INTRODUCTION	05
2. GENERAL DESCRIPTION	05
3. MACHINE OVERVIEW	06
4. INTENDED USE	07
5. TECHNICAL DETAILS	08
5.1 SPECIFICATIONS	08
5.2 PARTS SUBJECT TO WEAR	08
5.3 NOISE EMISSION	08
6. SAFETY	09
6.1 GENERAL	09
6.2 SPECIFIC SAFETY INSTRUCTIONS	10
7. STORAGE	11
8. TRANSPORT	12
9. GETTING DOWN TO WORK!	12
9.1 PRELIMINARY CHECKS	12
9.2 GETTING DOWN TO WORK!	12
9.3 BALLAST PLATES - ADDITIONAL WEIGHT	12
10. MAINTENANCE	13
10.1 LUBRICANTS	13
10.2 MAINTENANCE SCHEDULE	13
10.3 REPLACING A PAD	13
11. TROUBLESHOOTING	14
12. WARRANTY CONDITIONS	15
13. REPAIRS	15
14. END OF SERVICE LIFE	15
15. PARTS	16
16. EU DECLARATION OF CONFORMITY	16

ADDRESSES

Design, Production, Sales and Service:

Crescent Industrial Ltd
Berrington House
Berrington Road
Leamington Spa
CV31 1NB
Tel: 0845 33 77 695
www.crescentindustrial.co.uk

FOREWORD

This manual is intended for everyone involved in putting this machine into use, and its operation, maintenance and servicing. These people must:

- Possess the necessary level of knowledge and qualifications to do their work.
- Have read and understood this user manual.
- Follow all given safety instructions.
- If necessary, have access to sufficient right-sized and good-quality tools.

This user manual, the type plate and stickers placed on the machine contain important safety information and as such form an integral part of the delivery. Store this manual in a safe place and pass it on if the machine is sold.

1. INTRODUCTION

Congratulations with the purchase of your floor treatment machine for cleaning, stripping, polishing, sanding and removing paint, coatings, adhesive residues, etc. You now have a machine specifically designed for your intended use at your disposal. It is built in accordance with the latest insights and most up-to-date techniques, and, provided the instructions in this manual are followed correctly, it will give years of trouble-free use. The aim of this manual is to familiarise yourself with operating the machine and to provide instructions for working with it safely and guidelines for periodic maintenance. Make sure you are familiar with the contents of this manual before starting to work with the machine so that you can use all its features optimally and safely. This user manual, the type plate and stickers placed on the machine contain important safety information and as such form an integral part of the delivery. If they are damaged or lost, they must be replaced. Copies can be obtained from your supplier.

The machine is pre-assembled on delivery and is completely ready for carrying out scrubbing/buffing/polishing work. Make sure you know how to do this work before you start using the machine. On delivery, verbal instructions will be given about operating the machine, safety procedures and necessary maintenance. If this is not possible, the buyer is responsible for providing correct instructions. The machine offers a large number of possibilities for treating a floor. Crescent Industrial provides users with helpful user videos online to help you get the most out of your machine. Go to www.crescentindustrial.co.uk to find a training centre near you.

2. GENERAL DESCRIPTION

EX55-OCS Oscillating Floor Cleaning Machine is designed for easily cleaning floors along the edges, and in corners and smaller spaces. After fitting special pads, these machines can also be used for (solvent-free!) stripping or sanding/polishing parquet floors.

The plastic surround bumper makes it possible to work in tight corners. The Topfloor oscillating floor cleaning method is known for its uniqueness with its high number of oscillations of 2,800 a minute. This makes the effect of the pads unrivalled.

The machine is easy to use and requires no effort, because it is as if it hovers over the floor. The basis of the machine is a robust, sturdy stainless steel frame on which the pad holder with oscillating rubbers is attached. A large-size eccentric electric motor that drives the pad holder is mounted on the frame. When in operation, the machine is guided over the floor on a wheelset by pushing a stainless steel shaft ending in a T-handle that can be adjusted to suit any height

3. MACHINE OVERVIEW

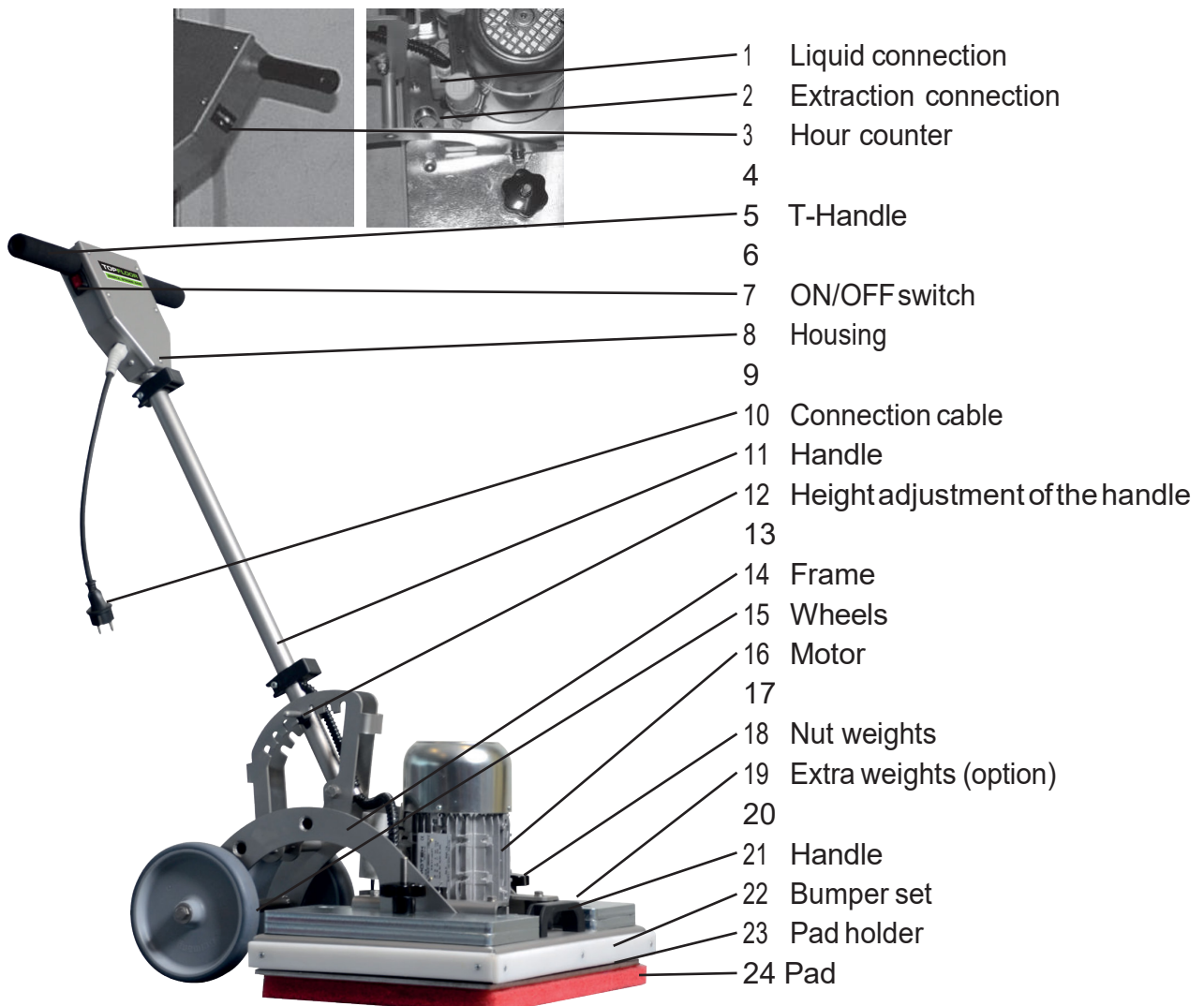

4. INTENDED USE

The EX55-OCS floor treatment machine is designed for:

- Cleaning
- Stripping
- Polishing
- Sanding
- Levelling
- Buffing

small and medium-sized hard and water-resistant floor surfaces using task-specific pads and/or accessories. The duty cycle is 100% for normal professional use. Machines fitted with an IP54 plug can be used with (scrubbing) water.



WARNING!

TOPFLOOR disclaims all responsibility in advance for damage caused as a result of any use other than described above!!

Topfloor has – not yet - tested and approved the use of the machine for other purposes. With respect to other possible uses, we recommend you contact Crescent Industrial IN ADVANCE to discuss whether the machine is suitable. When working, the operator stands BEHIND the machine loosely holding the T-handle.



WARNING!

These machines do NOT comply with ATEX requirements and may NOT be used in an ATEX environment!!



According to information given on the website www.arboportaal.nl the risk of employees suffering hearing loss starts at exposure to a noise level of 80 dB(A). Under the Working Conditions Act, the employer must provide hearing protection if the local noise level exceeds this value. Employees may only work in an environment with a noise level of 83 dB(A) for four hours without hearing protection, there must not be an unacceptably high risk of hearing loss and they may not be exposed to high noise levels during the following four hours. Employees are obliged to wear hearing protection if they are on average exposed to a noise level of 85 dB(A) on a daily basis

5. TECHNICAL DETAILS

5.1 Specifications

Height:	1,25 m
Width:	0,70 m
Depth:	0,55 m
Weight:	ca 45 kg, basis machine (geen ballast)
Ballast:	standard 1 set (=12kg) max 6 sets (=72kg)
Voltage:	220V-240VAC @ 50Hz
Current:	max 8A (input)
Power:	1200W
Insulation:	Rim earthing
Insulation class:	IP54 (dust-tight /splash-proof)
Inclination:	Max 2%

5.2 Parts subject to wear

Machine parts subject to wear are not covered under the warranty conditions due to:

1. additional contact with the product or
2. normal wear and tear during use

The parts of this machine that are subject to wear are:

- The oscillating rubbers
- The pads

5.3 Noise emission

The measured noise level of the machine when in operation is 60 dB(A). Test results show that the machine's noise emission when in operation depends largely on the surface on which and the space in which it is used. Spatial echo can lead to significantly higher noise levels. In these situations, we would recommend making hearing protection permanently available.



6. SAFETY

6.1 General



WARNING!

Almost all accidents are the result of: reduced concentration, inadvertence, negligence or misjudgement! Be sure to work slowly and carefully!

Always make sure the workplace is adequately illuminated. If necessary, place temporary additional (construction site) lighting to maintain sufficient oversight. Everyone involved in putting the machine into operation and its assembly, operation, maintenance and servicing, must:

- Possess the necessary level of knowledge and qualifications to do their work.
- Have read and understood this user manual.
- Follow all given safety instructions.
- If necessary, have access to sufficient right-sized and good-quality tools.



WARNING!

Improper use or operating the machine without having the necessary experience causes an immediate risk of physical injury, and damage to the machines and the environment. Keep bystanders a safe distance away from the machine while in operation!



WARNING!

Regular inspections and scheduled preventive maintenance reduce the chance of malfunctions during operation. Read through the user manual carefully before starting the machine!



Warning!
Electric Voltage!



Please read the user manual carefully before starting the machine!



Wear ear protection!



Use a dust mask when grinding!



WARNING!

Electrical hazard! Wearing hearing protection and a dust mask is compulsory when carrying out dry sanding work. This machine does NOT comply with ATEX requirements

6.2 Specific safety instructions



ATTENTION!

The machine's plug must be removed from the power socket whenever any form of maintenance is carried out.

This Topfloor floor treatment machine may NOT be used for cleaning floors that release substances that form a risk to the health of the operator or bystanders, or the environment! Only use this Topfloor machine on suitable floor surfaces. If you have any doubts or questions, always contact Topfloor or your local dealer.



ATTENTION!

Verify that the switch is set to "OFF" before inserting the machine's plug in the power socket!! Move the machine carefully over steps/stairs.



ATTENTION!

The machine is supplied with an extension cable as standard. The reach of the machine may not be lengthened with an additional extension cable.

Never scrub over the extension cable.

If you accidentally move the machine or scrub over the cable, switch off the machine and remove the plug from the power socket. Check the cable carefully for damage (water can also penetrate through small cracks in the cable!)

ATTENTION!! RISK OF ELECTRIC SHOCK!

The machine is UNSUITABLE for operating completely submerged. Attempting to do this can cause life-threatening situations



ATTENTION!

The machine may only be used with earthed power sockets and an earth leakage circuit breaker

The use of this floor treatment machine is subject to applicable safety and working conditions regulations. In addition to the instructions in this user manual, generally accepted occupational health and safety regulations must always be followed. All forms of improper use must be avoided.



ATTENTION!

You are working with an electric machine and (scrubbing) water. Make sure the earthing and earth leakage circuit breaker are working correctly!! Make sure that none of the cables in use are damaged!! You should preferably wear shoes with rubber soles!!

During the warranty period, a service technician approved by Topfloor may work on the machine.



ATTENTION!

Before changing parts or accessories, ALWAYS make sure that the plug has been removed from the power socket!



ATTENTION!

Stay at least 2m away from the edge of a swimming pool, pond or open water!!

7. STORAGE

If the machine will not be used for a longer period, it is advisable to carry out the following:



ATTENTION!

Always be careful when using a hose/blower!

- Clean the machine with a damp cloth.
- Carry out scheduled maintenance; see Section 10
- If necessary, apply a protective coating.
- Store the machine in a dry space.

8. TRANSPORT

The basic machine weighs approximately 16 kilos and it can be lifted by one person.

9. GETTING DOWN TO WORK!

9.1 Preliminary checks

You are working with (scrub) water and a 220 V machine. Make sure that:

- The mains voltage is 220 V
 - The earth connection functions properly
 - A GFCI (Ground Fault Circuit Interruptor) is installed.
- Check the cables for damage: both the short power cable as well as the extension cord!
- If you detect any deviations: solve these first before you start to work!
- Before starting treatment with the EX55-OCS, examine the floor on colour and shape retention.
- Before you start, check if the correct pad for the job is attached.
- Check that at least one set of weights is installed, but no more than six sets!
- The number of weights on the left and right-hand side of the motor must be equal!

9.2 Getting down to work!

- Move the machine to the location where it will be used.
 - Adjust the handle to a suitable working height and make sure it is locked properly in position!
 - Check whether the switch is set to OFF.
 - Unwind the extension cable (if used) completely and insert the machine's plug into an earthed power socket.
- Push the switch to ON position. The motor will start and the pad will start to work.
- While working the machine, you can easily push it around in any direction without requiring a large amount of force. Work in straight lines, not by moving the machine from left to right.
- Always switch off the machine immediately after stopping work so you do not damage the floor. Remove the plug from the power socket.

10. MAINTENANCE



ATTENTION!

Regular inspections and scheduled preventive maintenance reduce the chance of malfunctions during operation.

10.1 Lubricants

No specific lubricants are recommended for the Topfloor Oscillating Floor Cleaners.

10.2 Maintenance schedule

10.2.1 Daily (before starting work)

- Check all cables for damage. **Repair damaged cables before starting work!**
- Check the pad for wear. A worn pad reduces the operating speed.
- After using the machine with chemical cleaning agents, wipe the machine down with a damp cloth to prevent corrosion of the stainless steel components.
- Check for loose nuts and bolts.

10.2.2 Monthly

- Check whether the plate under the pad holder still has enough grip to hold the pad in position.
- Check the oscillating rubbers for cracks. **Have cracked oscillating rubbers replaced!**

10.2.3 Yearly

- Have the machine tested in accordance with the compulsory occupational health and safety test (NEN 3140) for electrical machines.

10.3 Replacing a pad

If the operating speed drops, or the machine's performance declines, the pad has probably accumulated a large amount of dirt or is worn and it has to be cleaned or replaced. The pad is attached to the plate with Velcro.

Proceed as follows:

- Switch the machine off.
- Remove the plug from the power socket.
- Put the handle in the highest position.
- Tip the machine backwards so that the handle rests on the ground and the pad is vertical.
- Pull the pad off the pad holder.
- Place the new pad carefully on the pad holder and push it firmly into position.
- Return the machine to the upright position.
- Put the handle back in the preferred position.
- Insert the machine's plug in the power socket.
- Switch the machine on and continue working.

11. TROUBLESHOOTING

1) The machine will not start:

- Check the earth leakage.
- Check the supply voltage.
- Check the cables for damage.
- Contact your supplier.

2) The machine makes a rattling sound. **STOP IMMEDIATELY!!**

CHECK THE MACHINE BEFORE CONTINUING WORK!!

- An oscillating rubber is loose: Tighten!
- A rubber has torn: Ensure that it is replaced!
- The eccentric bearing is worn: Ensure that it is replaced!

12. WARRANTY CONDITIONS

In accordance with the Metaalunie Conditions, the machine has a warranty period of six months after delivery. This means that, during this period, material and manufacturing defects will only be repaired free of charge **AFTER THEY HAVE BEEN ASSESSED BY A QUALIFIED TOPFLOOR ENGINEER'** Transportation/travelling expenses shall be for the purchaser's account.

The warranty DOES NOT cover defects caused as a result of:

- demonstrable overloading of the machine.
- using the machine for purposes for which it is not built.
- demonstrable poor maintenance.
- not properly following the instructions in this manual.
- the use of the machine by unauthorised people.
- repairing the machine using non-OEM parts
- modifying the machine without obtaining written permission from TOPFLOOR

The warranty DOES NOT cover parts subject to wear as referred to in Section 5.

13. REPAIRS

The machine has a simple construction and parts diagrams are available on our website. Repairs may only be carried out by competent, experienced personnel! This manual does not contain detailed descriptions of repair procedures. If you have any questions or wish to have repairs carried out by professionals, you can always contact TOPFLOOR.

14. END OF SERVICE LIFE

You must always comply with current local requirements and guidelines for working safely and the responsible disposal of worn out machines! After the machine has been in use for a long time and reached the end of its technical service life, follow the disposal procedure below:

- Clean the machine.
- Dismantle electrical components so they can be sent for recycling.
- Dismantle the plastic components so they can be handed in as separated waste.
- The remaining steel components can be sent for scrap.

*Follow the ECMR (European Cleaning Machines Recycling) guidelines;
go to www.ecmr.nu for more information.*

15. PARTS

All parts lists are available on all Topfloor machines on the website: www.crescentindustrial.co.uk
Contact TOPFLOOR for further information about ordering parts and delivery times!! When ordering parts, please specify the serial number specified on the machine's the type plate.

16. EU DECLARATION OF CONFORMITY

IN ACCORDANCE WITH ANNEX IIA OF THE MACHINERY DIRECTIVE 2006/42/EC
We, TOPFLOOR., having our business address at Crescent Industrial Ltd.

We, **TOPFLOOR – Industrial Floor Cleaning Machines**
Crescent Industrial, Berrington House,
Berrington Road, Leamington Spa,
CV31 1NB

Declare under our sole responsibility that the product:

Brand: Topfloor
Machine: Floor preparation machine
Type: EX55-OCS

To which this declaration applies, meet all stipulations in the following directives:

Machinery Directive 2006/42/EG
Low Voltage Directive 2014/35/EU
EMC richtlijn 2014/30/EU

And in conformity with the following standards and/or other normative documents:

NEN-EN-1050:1997 Risk reduction

Drawn up in: Leamington Spa
05-04-2017

Topfloor (Crescent Industrial Ltd)
SJ Stacey, director

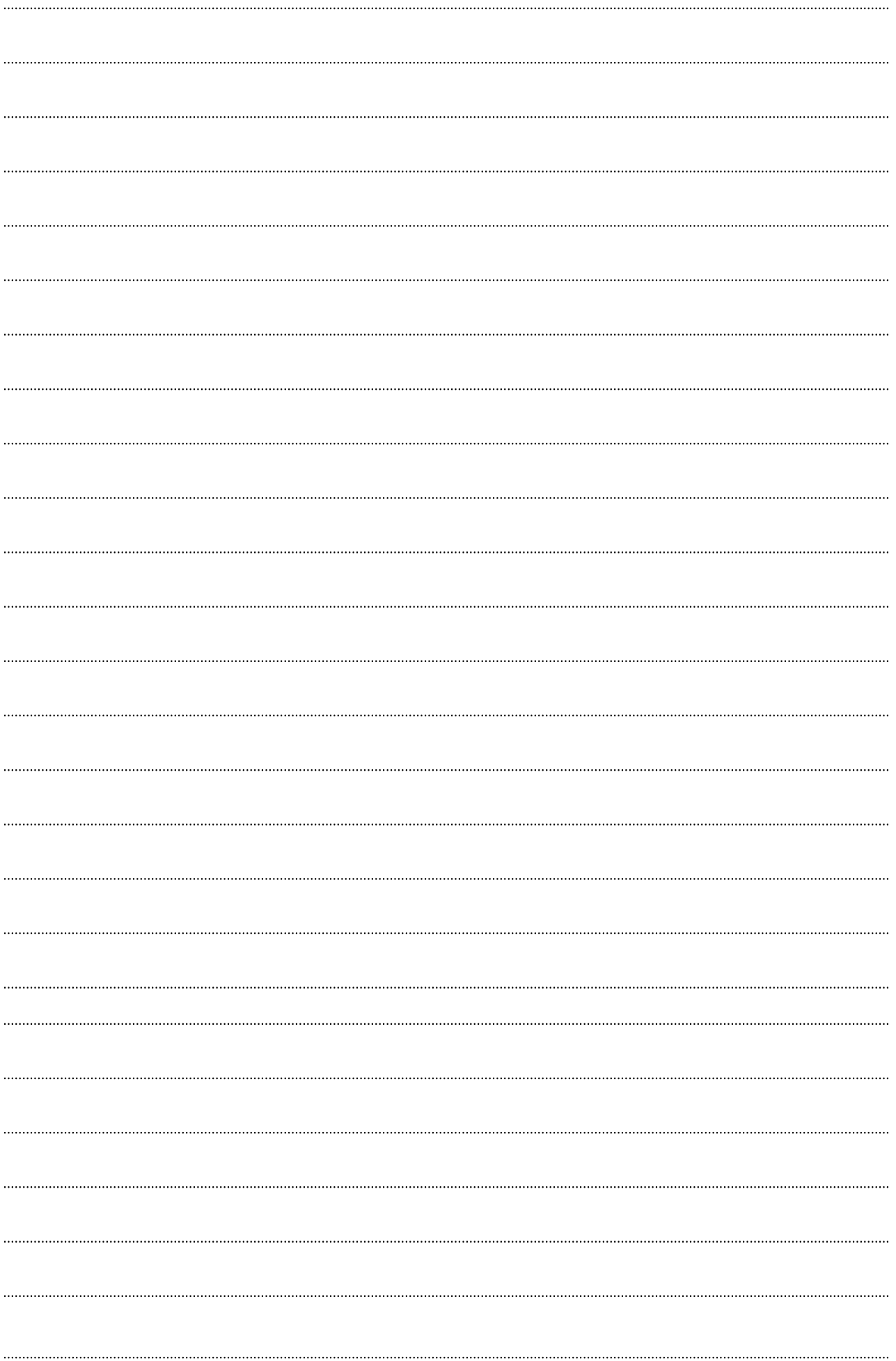

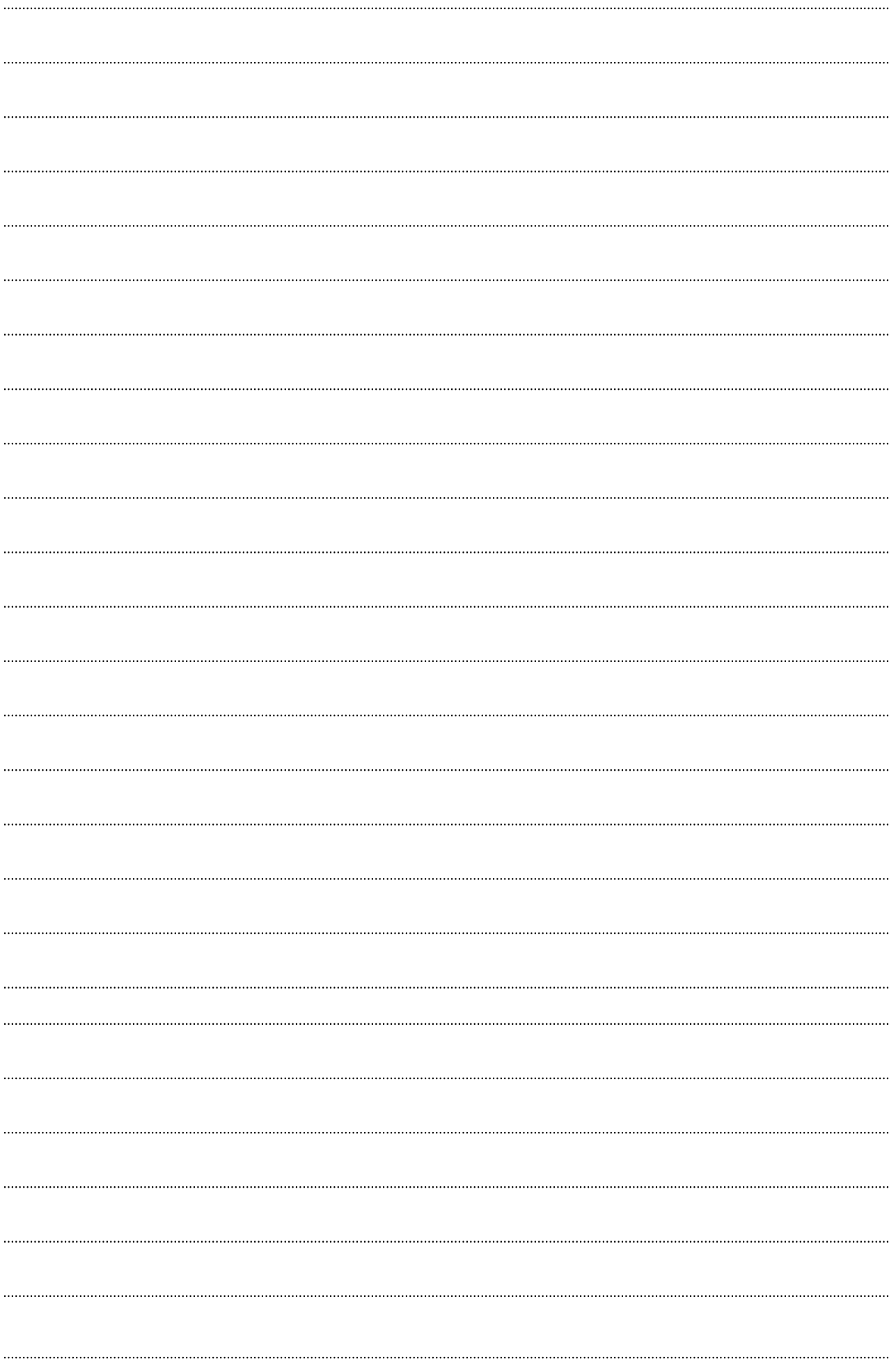

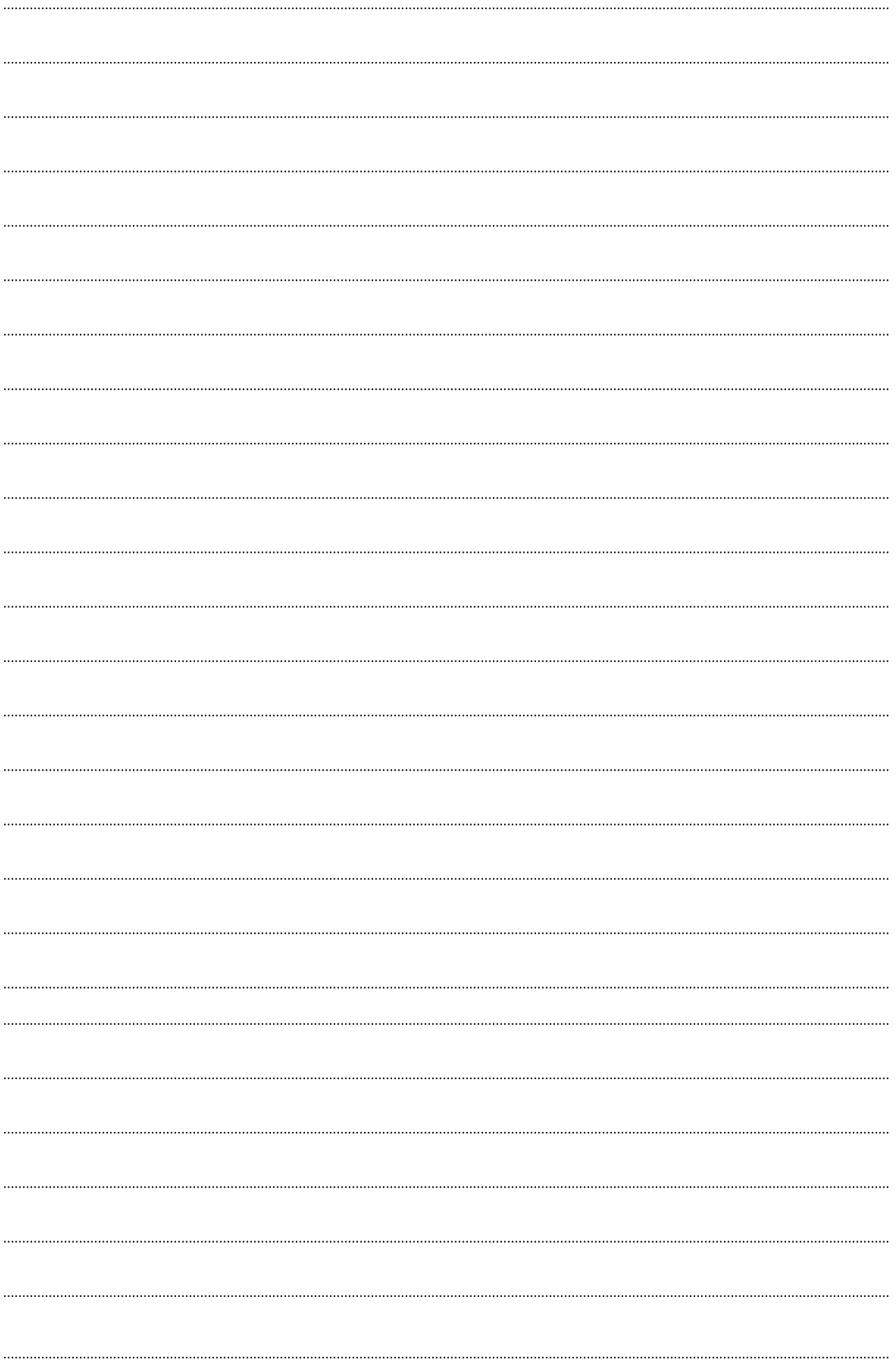

TOPFLOOR

SIMPLE, STRONG, SAFE

We supply a full range of cleaning equipment for rental or purchase.

For more information, or a cleaning solution to suit your business, please get in touch –

For a more comprehensive product range, please visit our website.

Distributed by:



Address

Crescent Industrial Ltd
Berrington House,
Berrington Road,
Leamington Spa
CV31 1NB

Contact

t: 0845 33 77 695
f: 0845 33 78 695
e: info@c-ind.co.uk

www.crescentindustrial.co.uk