

Parts Diagrams and Lists



TABLE OF CONTENTS

DESCRIPTION	PAGE
Chassis System	2-3
Control System	4-5
Decal System.....	6-7
Electrical System	8-9
Recovery System.....	10-11
Scrub System-Cylindrical.....	12-13
Scrub System-Cylindrical-Skirt Assemblies	14-15
Scrub System-Disk BR755	16-17
Scrub System-Disk BR855	18-19
Scrub System-Disk Skirt Assemblies [before January 20 2014 and after April 13 2015].....	20-21
Scrub System-Disk Skirt Assemblies [between January 20 2014 and April 13 2015]	22-23
Solution System.....	24-25
Squeegee System	26-27
Squeegee Assy-BR755.....	28
Squeegee Assy-BR855.....	29
Ladder Diagram	30-31
Optional Kits & Accessories	32
Brush Selector Guide-Disk	33
Brush Selector Guide-Cylindrical.....	34
Squeegee Blade Selector Guide	35

WHEN ORDERING PARTS

* Use the part numbers from the "Ref. No." columns in this parts list. If the "Ref. No." column is blank; look under the "Kit" column to identify which kit contains the part in question, then use the kit callout, for example "K1", to find the "Ref. No." for that kit.

Kit	Item	Ref. No.	Qty	Description
K1	1		16	Washer Flat 3/16 Zinc Plat
K1	2		2	Screw-BHS-Brass-10-32x3/8-MS
K1	3		3	Washer EPDM 7/32 X 1/8
	4	805	1	Chain-Cover
	5	905	2	Caster Swivel 4 Gray Non MA
K1	6		2	Nut, Hex Nyl Loc 10-24
K1	7		3	Scr- Hex SS 1/4-20 X .75
K1	8		16	Scr, Hex Hd Loc 1/4-20 x .50
K1	9		3	Wsh, Flt SS .260 X 1.000 X .074
	10	56113012	1	Solution Tank
	11	56113034	2	Hinge Plate
K1		56113103	1	Kit-Hardware Solution Tank

* Specify the model and serial number of the machine.

* Use the space below to record the model and serial number for future reference.

Model _____ Serial No. _____

CHASSIS SYSTEM

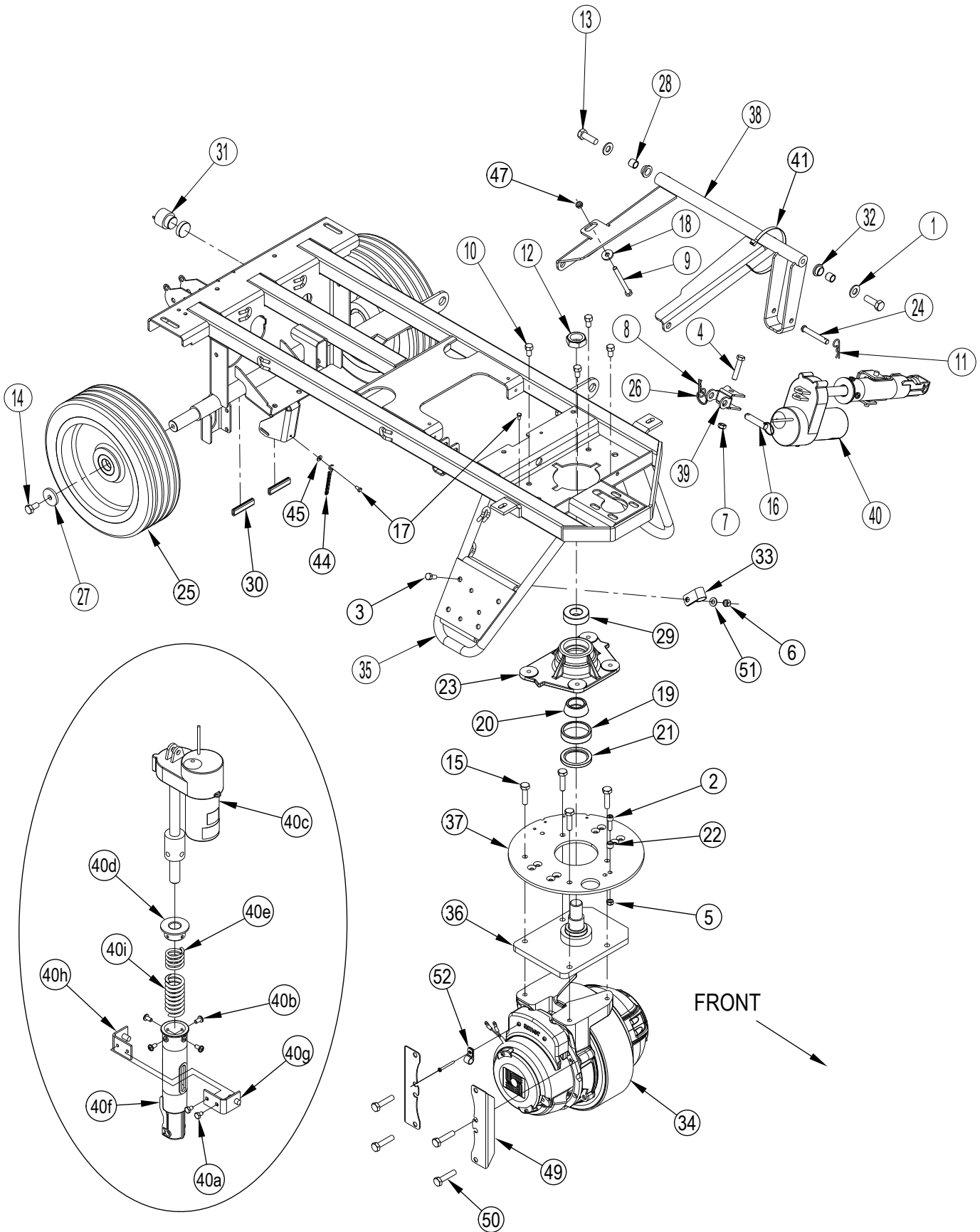

FRONT

CHASSIS SYSTEM

Item	Ref. No.	Qty	Description
1	56001879	2	Wsh, Flt SAE 1/2
2	56002129	1	Scr, Soc Hd 5/16-18 X 1.00
3	56002667	1	Scr Hex 5/16-18 X .75
4	56002684	1	Scr, Hex 3/8-16 X 1.75
5	56002826	1	Nut, Hex Nyl Loc-Thin 5/16-18
6	56002701	1	Nut Hex Nyl Loc 5/16-18
7	56002841	1	Nut, Hex Nyl Loc-Thin 3/8-16
8	56002959	1	Pin, Cotter Hair
9	56003008	1	Scr, Hex Thd To Hd 5/16-18 X 3.50
10	56003040	4	Scr, Hex Hd Loc 3/8-16x.62
11	56003120	1	Pin, Cotter Hair .0915 X .375
12	56003220	1	Nut, Hex Nyl Loc-Thin 1-14
13	56003412	2	Scr, Hex Loc M12-1.75 X 35mm
14	56003442	2	Scr, Hex Loc M10-1.5 X 20mm
15	56003491	4	Scr, Hex M10-1.5 X 40mm
16	56003679	1	Pin, Ring .50 X 1.63
17	56009012	2	Scr, Hex Thd Form 10-24 X .38
18	56009122	1	Wsh, Flt .344 X .938 X .125
19	56158143	1	Bearing Cup
20	56158151	1	Bearing Cone
21	56171081	1	Seal, Shaft
22	56244941	1	Bushing
23	56314032	1	Block, Bearing
24	56003803	1	Pin-Clevis SS .375 x 2.50
25	56382693	2	Wheel TSB-FC-2015-033
26	56317071	1	Ring
27	56367117	2	Wsh, Flt .406 X 1.5 X .1875
28	56367206	2	Bushing
29	56378380	1	Bearing Ball
30	56412122	2	Trim Edge
31	56412177	1	Horn/Backup Alarm (H2)
32	56420160	2	Bearing, Flange
33	56469380	1	Clamp-P

Item	Ref. No.	Qty	Description
34	56601050	1	Motor / Drive Wheel (M1)
[]	56601472	1	Tire With Hub
[]	56601473	1	Motor
[]	56601509	1	Carbon Brush Kit
[]	56601471	1	Tire
[]	56601507	1	Electromagnetic Brake
[]	56422174	1	Tire Puller Kit
[]	56504482	1	Drive Motor Cover
[]	56504481	1	Drive Motor Cover
[]	56380310	1	Brake Lever Kit
35	56114199	1	Chassis, Weldment
36	56601077	1	Spindle Weldt
37	56314116	1	Plate, Steering
38	56601239	1	Deck Linkage, Weldt
39	56601328	1	Yoke, Actuator
40	56601432	1	Lift Actuator Assembly (M4)
40a	56009019	2	Scr, Hex Thd Form 1/4-20 X .38
40b	56009062	4	Scr, Pan Phil Thd Form 1/4-20 X .50
40c	56393303	1	Actuator, Motor
40d	56396268	1	Spring Housing Guide
40e	56412071	1	Compression Spring
40f	56412262	1	Housing, Spring
40g	56420019	1	Nut Retainer
40h	56420020	1	Nut Retainer
40i	56601470	1	Compression Spring
41	56477613	1	Tie-Cable
44	56601716	1	Ground Chain
45	56009011	1	Wsh, Int Shprf 10
47	56009086	1	Nut Hex Jam 5/16-18
49	56344100	2	Bracket-Wheel
50	56003445	4	Scr Hex Nyl Loc M10-1.50X45MM
51	56002220	1	Wsh Flt Std 5/16
52	56486112	1	Clamp, P

[] = Not Shown

CONTROL SYSTEM

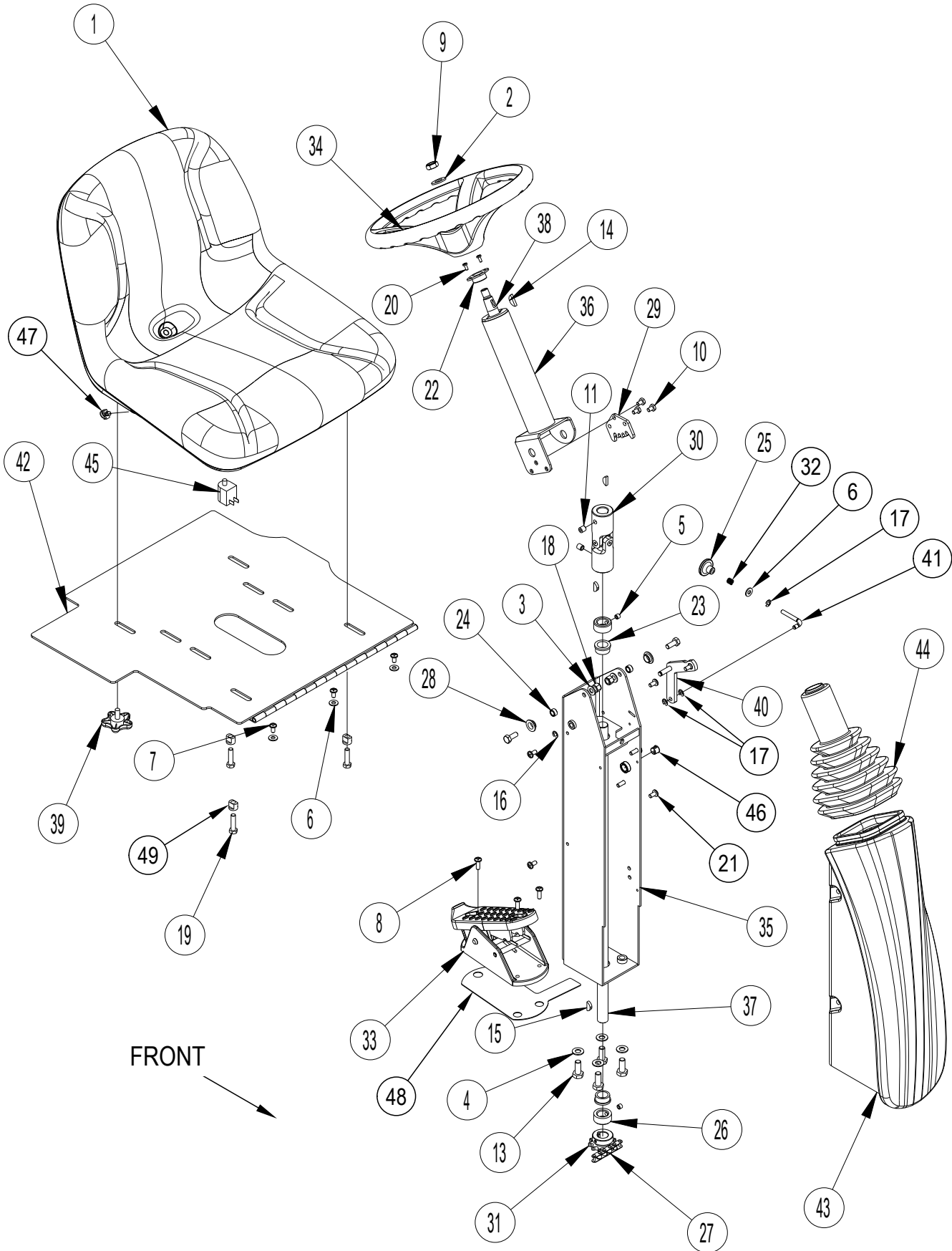

CONTROL SYSTEM

Kit	Item	Ref. No.	Qty	Description
	1	56383187	1	Seat NOTE 1
	2	56001879	1	Wsh, Flt SAE 1/2
	3	56001939	2	Wsh, Flt SAE 5/16
	4	56002063	4	Wsh, Flt SAE 3/8
	5	56002086	2	Scr, Soc Set Loc 5/16-18 X .25
K1	6	56002859	4	Wsh Flt Sae Ss 1/4
K1	7	56003119	3	Scr Pan Phil Ss 1/4-20 X .50
	8	56002957	3	Scr Pan Phil Ss 1/4-20 X .75
	9	56002843	1	Nut, Hex Nyl Loc-Thin 1/2-13
	10	56002933	3	Scr, Hex Hd Loc 1/4-20x.38
	11	56003081	2	Scr, Soc Set Loc 3/8-16 X .38
	12	56003179	2	Scr, Hex Thd To Hd M8-1.25 X 20mm
	13	56003186	4	Scr, Hex Thd To Hd M10-1.5 X 25mm
	14	56003227	1	Key, Wdf .62 X .19
	15	56003228	3	Key, Wdf .75 X .19
	16	56003261	1	Ring, Ret Ext Type E 0.31 Dia
	17	56003268	3	Ring, Ret Ext Type E Reinf. 0.25 Dia
	18	56003389	2	Nut, Hex Nyl Loc M8-1.25
K1	19	56001834	3	Scr-Hex 5/16-18 x 1.25
	20	56009051	2	Scr, Pan Phil Thd Form 8-32 X .38
	21	56009062	4	Scr, Pan Phil Thd Form 1/4-20 X .50
	22	56100393	1	Bushing
	23	56250414	2	Bearing, Flange
	24	56320595	2	Bushing .32x.50x.28
	25	56362778	1	Knob
	26	56367095	2	Collar, Shaft
	27	56412198	1	Chain, Roller
	28	56413211	2	Bearing, Flange .625 X .500 X .250
	29	56413658	1	Ratchet, Steering Column
	30	56454081	1	Universal Joint
	31	56471148	1	Sprocket
	32	56578222	1	Spring, Compression
	33	56601052	1	Foot Pedal Assy
	34	56601060	1	Steering Wheel
	35	56601850	1	Lower Column Weldment
	36	56601169	1	Upper Column Weldment
	37	56601223	1	Shaft, Lower Steering
	38	56601224	1	Shaft, Upper Steering
	39	56601271	1	Knob, 5/16 Stud
	40	56601284	1	Steering Pawl Weldment
	41	56601292	1	Pull Lever
	42	56601362	1	Seat Panel Weldment
	43	56601484	1	Shroud, Lower Column
	44	56601500	1	Boot, Steering
	45	7-82-00050	1	Switch (S2)
	46	56601683	1	Plug-Cap
	47	56315382	1	Clip-Conduit
	48	56601601	1	Foot Pedal Plate
K1	49	56383230	3	Flanged Bushing Seat

Service Kits

K1	56114304	1	Hardware Kit-Seat
-----------	----------	---	-------------------

NOTE 1: Seat 8-69-00022 (steel seat pan) has been replaced by Seat 56383187 (plastic seat pan) in production. Please order Seat Kit 56383240 when replacing Seat 8-69-00022.

DECAL SYSTEM

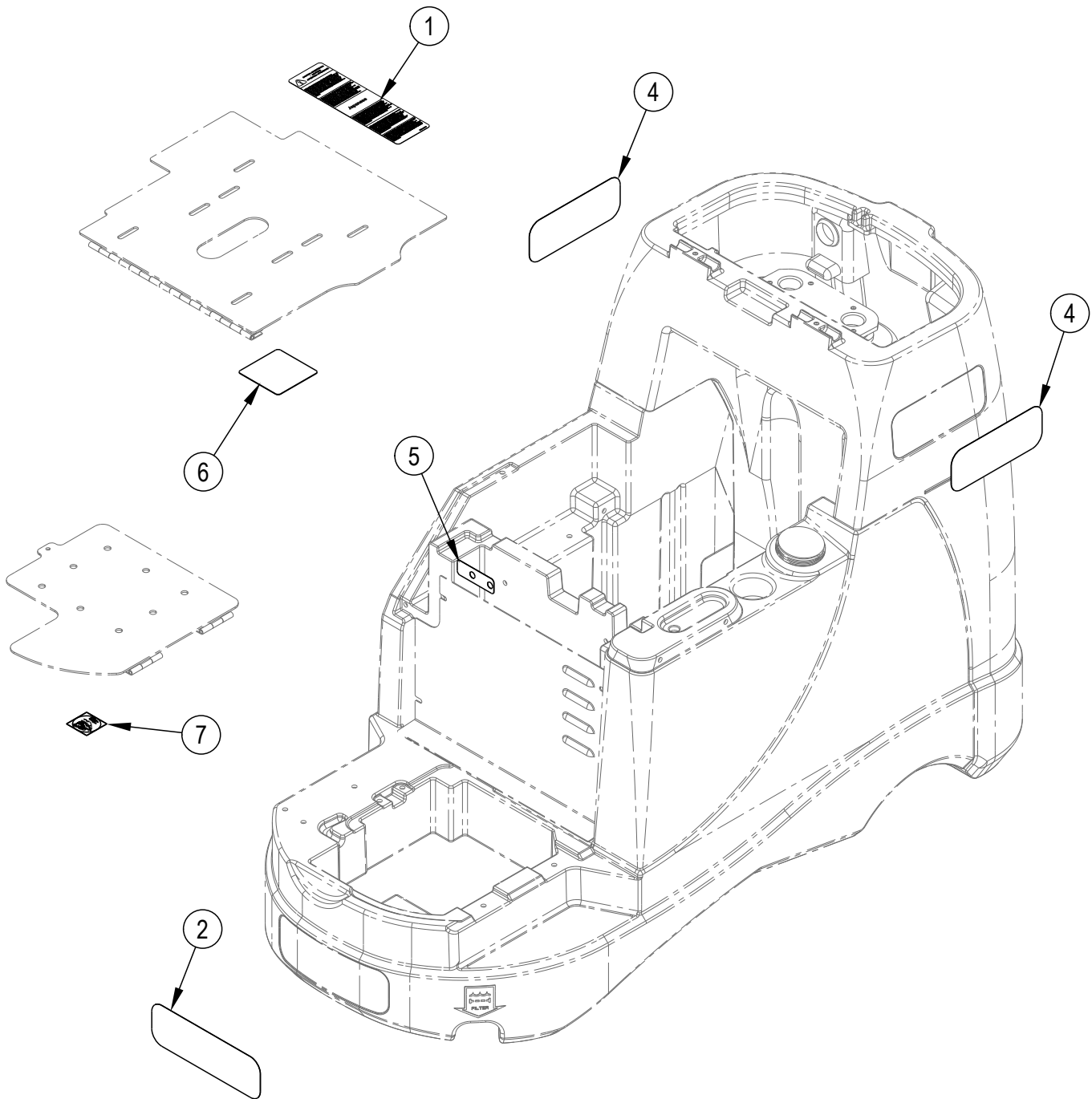

DECAL SYSTEM

Item	Ref. No.	Qty	Description
1	56014601	1	Decal, Caution
2	56016731	1	Decal, Nilfisk
4	56601303	2	Decal, BR755
	56601305	2	Decal, BR855
5	56601414	1	Decal, Circuit Breaker
6	56601416	1	Decal, Battery Wiring
7	56380254	1	Decal, Open When Charging

ELECTRICAL SYSTEM

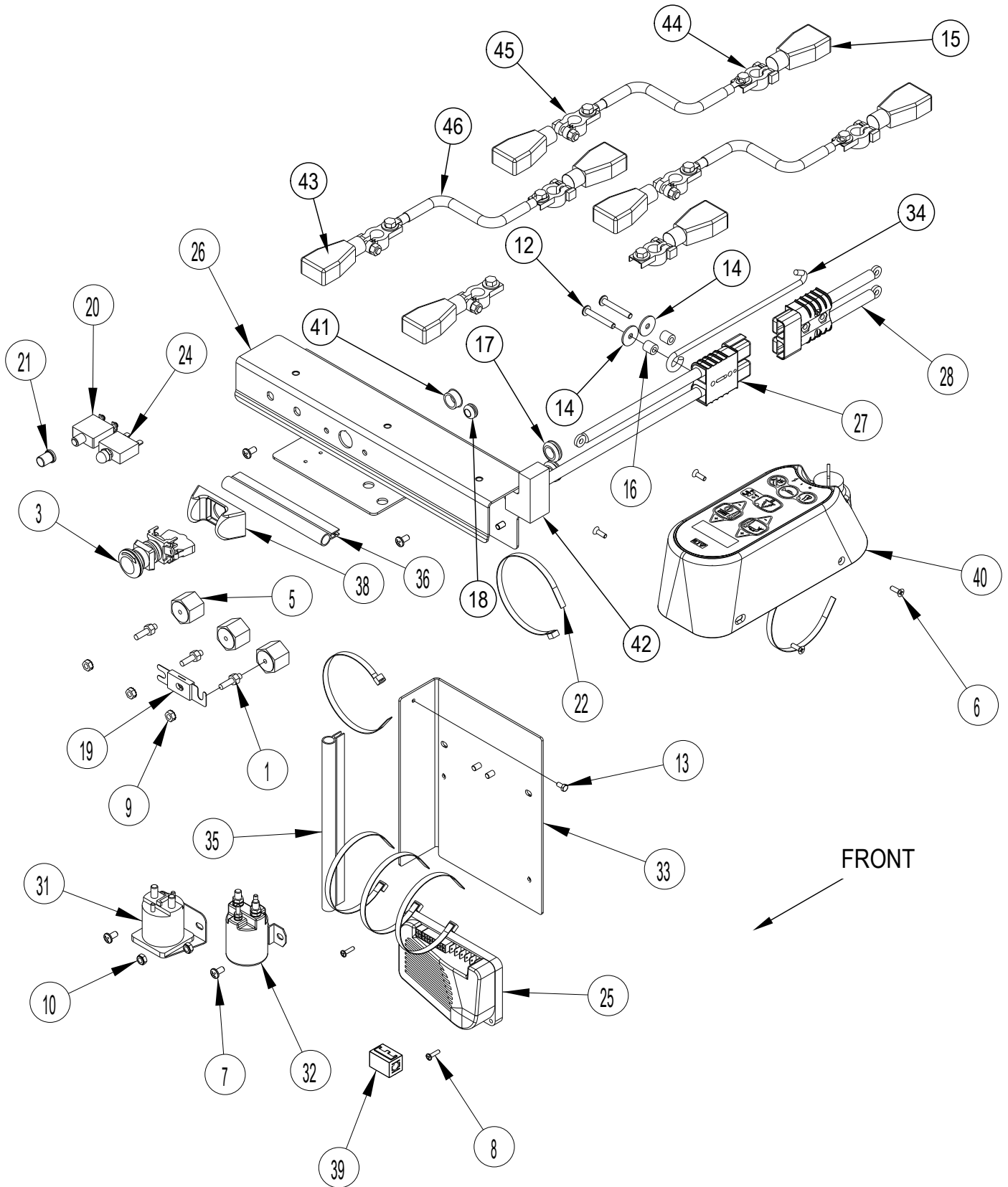

ELECTRICAL SYSTEM

Item	Ref. No.	Qty	Description
1	83302A	3	Stud, 1/4-20
3	56407130	1	Disconnect, Emergency (S4)
5	56469858	3	Electrical Mount
6	56003056	4	Scr Flt Phil Ss 10-24 X .62
7	56009069	4	Scr-Pan Phil Loc 1/4-20 X .50
8	56002146	2	Scr, Pan Phil 8-32 X .62
9	56002561	3	Nut, Hex W/ Shprf 1/4-20
10	56002840	2	Nut, Hex Nyl Loc-Thin 1/4-20
12	56002997	2	Scr, Pan Phil 1/4-20 X 1.75
13	56009012	1	Scr, Hex Thd Form 10-24 X .38
14	56009060	2	Wsh, Flt SS .260 X 1.000 X .074
15	2-00-05173	4	Bat Terminal Cover (Blk)
16	56046309	2	Spacer, Phenolic
17	56157376	2	Grommet
18	56321540	1	Grommet
19	56412089	1	Fuse, 150 Amp (F1)
20	56454429	1	Circuit Breaker, 70 Amp (CB1)
21	56459369	1	Boot, Reset Button
22	56477613	9	Tie, Cable
24	56507644	1	Circuit Breaker, 10 Amp (CB2)
25	56601061	1	Speed Control (A2)
26	56601854	1	Panel
27	56601171	1	Connector Assy
28	56601172	1	Connector Assy
[29]	56601174	1	Main Harness
[30]	56344205	1	Traction Drive Harness
31	56601183	1	Contactactor 24v, 100 Amp (K1)
32	56412179	1	Contactactor 24v (K2)
33	56601185	1	Panel
34	56601215	1	Prop Rod, Seat
35	56601251	1	Gasket
36	56601252	1	Gasket
[37]	56601431	1	Cable, Jumper
38	56601434	1	Emergency Button Guard
39	40849A	1	Suppressor EMI Split
40	56601565	1	Interface Panel Assy (A1)
[]	56601096	1	Kit, Interface Panel (Membrane Switch, Interface Panel)
[]	56303553	1	Key Switch (S1)
[]	56303526	A/R	Replacement Key Set
41	56900144	1	Plug, Cap
42	56601600	1	Foam Insert
43	2-00-05171	4	Bat Terminal Cover (Red)
44	L08812064	4	Terminal Clamp Batt
45	L08812063	4	Terminal Clamp Batt
46	56409485	3	Cable-Battery

[] = Not Shown

RECOVERY SYSTEM

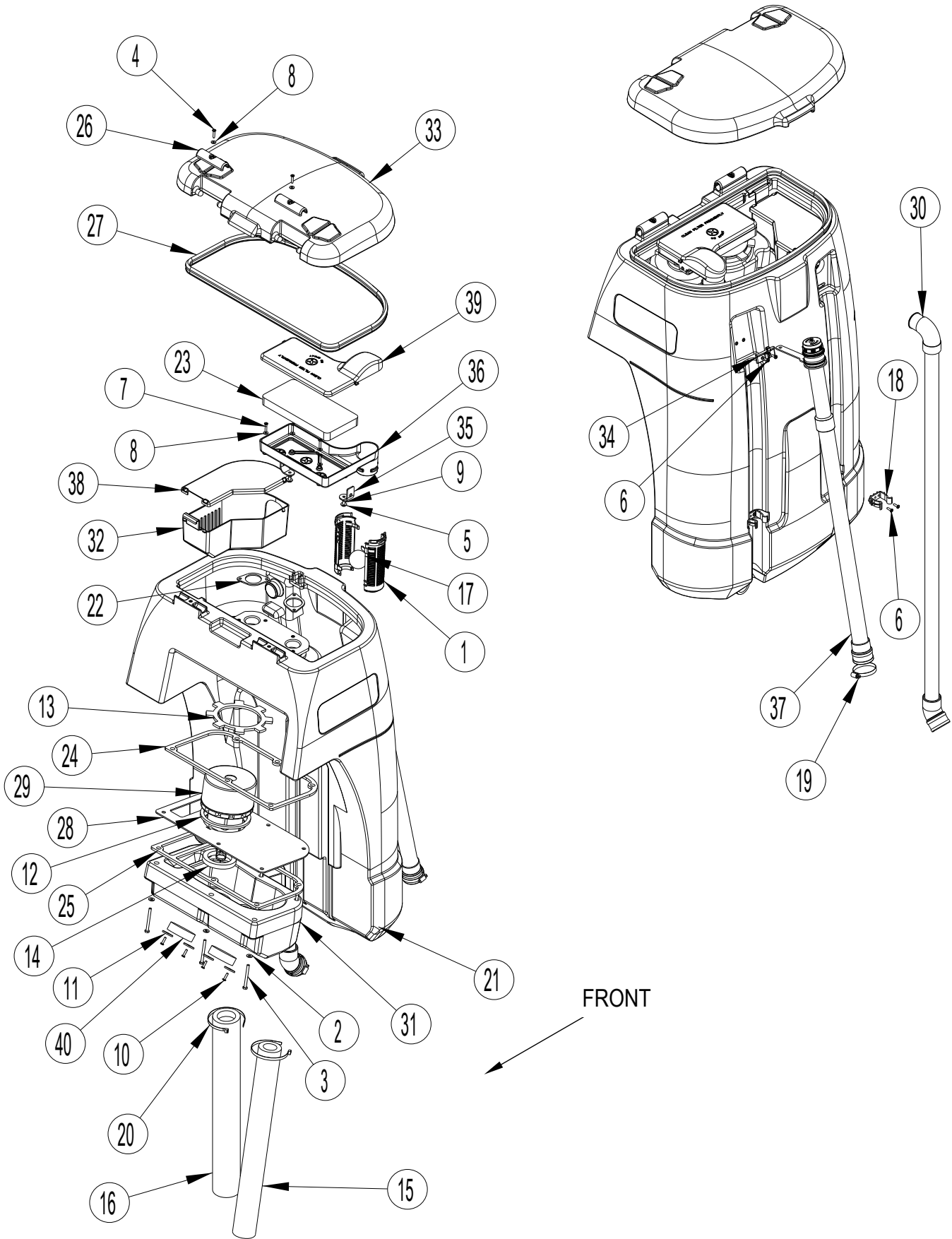

RECOVERY SYSTEM

Item	Ref. No.	Qty	Description
1	56324497	2	Cage, Float
2	56002098	6	Wsh, Flt SAE 1/4
3	56003867	6	Scr-Hex Hd Loc 1/4-20 X 3.00
4	56003951	2	Scr-Pan Phil Loc SS 10-24 X .88
5	56002859	2	Wsh, Flt SAE SS 1/4
6	56002896	6	Scr, Pan Phil SS 10-24 X .62
7	56002898	4	Scr, Pan Phil SS 10-24 X 1.00
8	56002916	6	Wsh, Flt SAE SS #10
9	56003799	2	Scr, Pan Phil SS Plastite 1/4-10 X .50
10	56009005	4	Scr, Pan Phil SS Type Ab 10-16 X .75
11	56003817	4	Wsh-Flt SS .281 x 1.25 x .05
12	56212143	1	Gasket, Vacuum Duct
13	56264103	1	Gasket, Vacuum Motor
14	56314760	1	Gasket, Vacuum Duct
15	56315375	1	Foam, Acoustical
16	56315847	1	Foam Tube Assembly
17	56391690	1	Ball, Float
18	56407361	2	Clamp, Plastic
19	56440213	1	Clamp, Hose SAE #32
20	56477613	2	Tie, Cable
21	56601120	1	Tank, Recovery
22	56601121	2	Gasket, Vac Filter
23	56601125	1	Filter
24	56601126	1	Gasket, Exhaust
25	56601127	1	Gasket, Vac
26	56601128	2	Hinge Clamp
27	56114185	1	Gasket-Recovery Tank
28	56601131	1	Vac Plate, Standard
29	56601488	1	Motor, Vac 24vdc (M5)
[]	56397098	1	Carbon Brush (set of 2)
30	56601136	1	Recovery Hose
31	56601137	1	Cover, Vac Motor
32	56601138	1	Strainer Basket
33	56601139	1	Recovery Lid
34	56601204	1	Hook, Drain Hose
35	56601250	2	Strap, Filter Cover
36	56601253	1	Filter Box
37	56383319	1	Drain Hose Assy-1.5
38	56601421	1	Cover, Debris
39	56601451	1	Cover, Fltr Box W/Gskt
40	56344168	2	Filter

[] = Not Shown

SCRUB SYSTEM-CYLINDRICAL

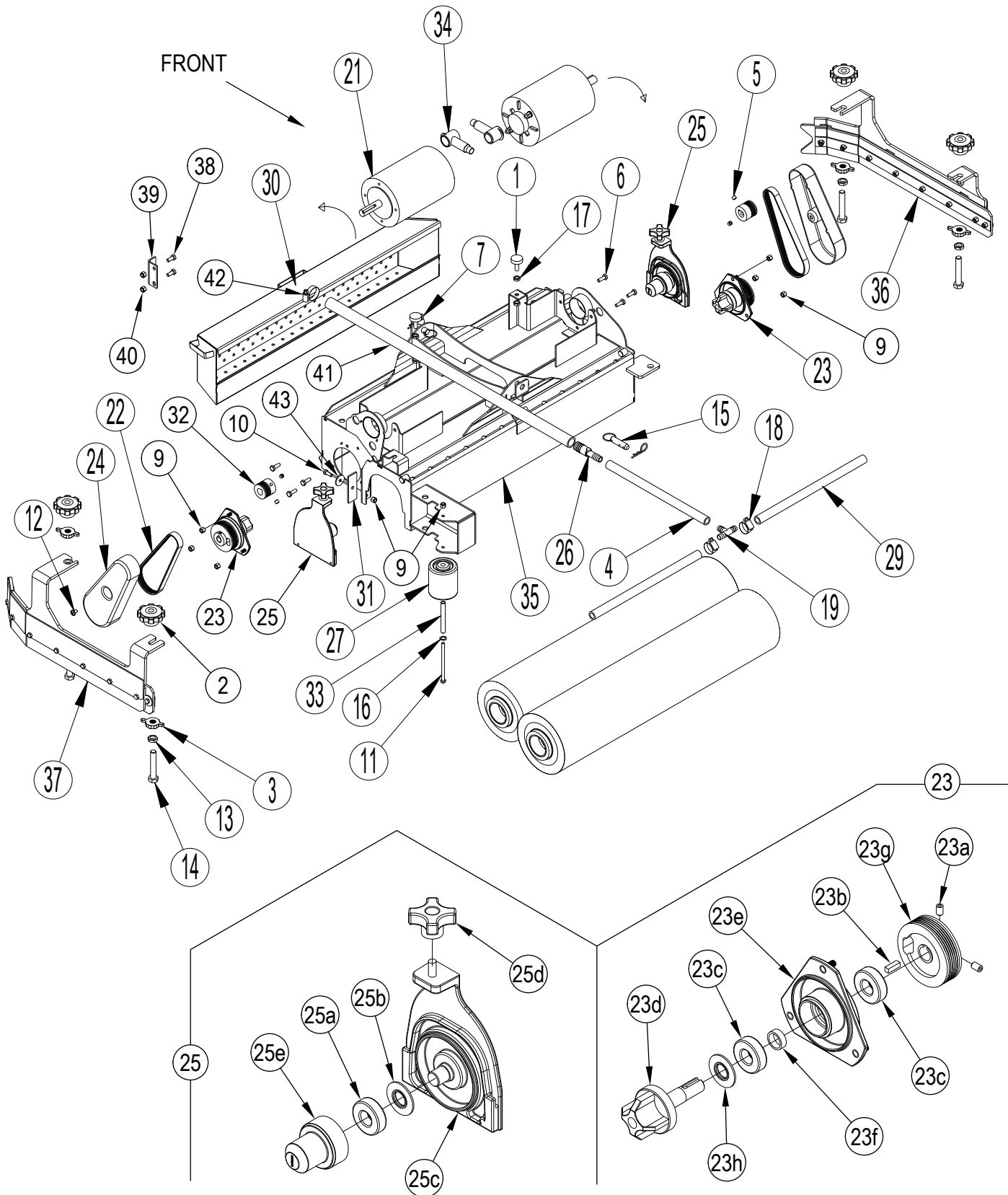

SCRUB SYSTEM-CYLINDRICAL

Item	Ref. No.	Qty	Description
1	56401783	2	Leveler
2	56380149	4	Knob TSBUS2010-1060
3	56601578	4	Knob
4	56409462	1	Hose, Spiral
5	56002086	4	Scr, Soc Set Loc 5/16-18 X .25
6	56002948	6	Scr, Hex Hd Loc 1/4-20 x .75
7	56002959	2	Pin, Cotter Hair
9	56003426	9	Nut, Hex Nyl Loc SS M6-1
10	56003431	2	Scr, Hex SS M6-1 X 16mm
11	56003939	1	Scr-Hex Ss M6-1 X 95mm
12	56003603	2	Scr, Pan Phil Thd Form 1/4-20 X .38
13	56003657	4	Nut, Hex Jam SS M12-1.75
14	56003658	4	Scr, Hex Thd To Hd SS M12-1.75 X 70mm
15	56003671	2	Pin, Ring .50 X 1.25
16	56009045	2	Wsh, Bowed .375 x .578 x .060
17	56009086	4	Nut, Hex Jam 5/16-18
18	56112771	2	Clamp, Hose SAE #10
19	56262549	1	Tee, Barb
21	56315061	2	Motor, 24 VDC, .5 HP, 1800 RPM (M7 / M8) TSBUS2010-1058
[]	56412287	1	Motor Brush / Spring Kit
[]	56412258	4	Brush Assy
[]	56412259	4	Brush Spring
22	56315321	2	Belt, Auto Tension
23#	56115318	2	Drive End Assy
23a#	56002930	2	Scr Soc Set Loc 1/4-20 X .38
23b	56003237	1	Key, Sq .19 x .62
23c	56106070	2	Bearing, Ball
23d#	56115319	1	Spindle-Long
23e	56381765	1	Bearing, Plate
23f	56407389	1	Spacer
23g#	56115316	1	Sheave, Poly-V
23h	56407558	1	Washer, Bearing
24	56315445	2	Cover, Belt
25#	56115344	2	Idler End Assy
25a	56106070	1	Bearing, Ball
25b	56407558	1	Washer, Bearing
25c	56315447	1	Idler Bearing Plate
25d	56407303	1	Knob
25e#	56115273	1	Hub-Idler
26	56315625	1	Barb, Coupler 1/2 X 3/4
27	56316089	1	Wheel
28	56316210	2	Harness, Brush Motor (Not Shown)
29	56316553	2	Manifold, PVC 28 Adv
30	56601049	1	Hopper Weld't
31	56407391	2	Blade
32	56407433	2	Sheave, Poly-V
33	56412176	1	Bushing
34	56493357	2	Insulator, Terminal
35	56601048	1	Housing Weld't
36	56601468	1	Left Skirt Assy
37	56601476	1	Right Skirt Assy
38	56002667	2	Scr-Hex 5/16-18 x .75
39	56601675	1	Bracket
40	56002701	2	Nut-Hex Nyl Loc 5/16-18
41	56379139	1	Tube PVC
42	56244969	1	Clamp Hose SAE 12
43	56009060	2	Wsh Flt Ss .260 x 1.000 x .074

[] = Not Shown

= Revised or new since last update

SCRUB SYSTEM-CYLINDRICAL SKIRT ASSEMBLIES

56601468 - Left Skirt Assy

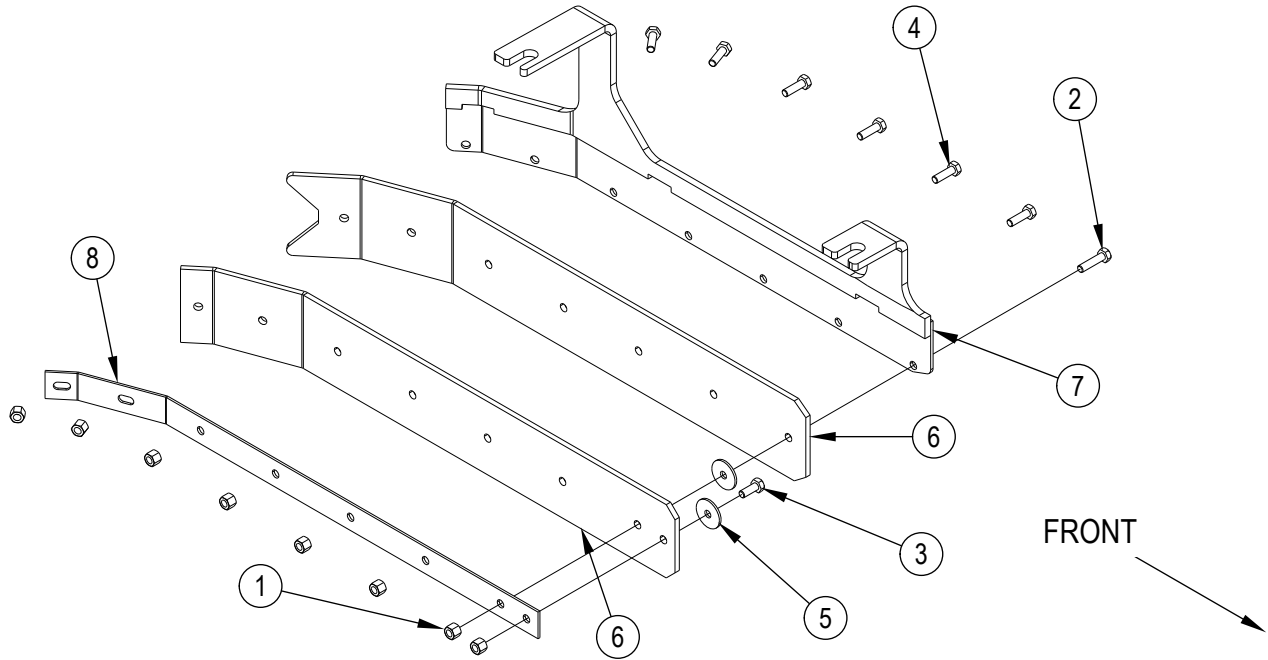

56601476 - Right Skirt Assy

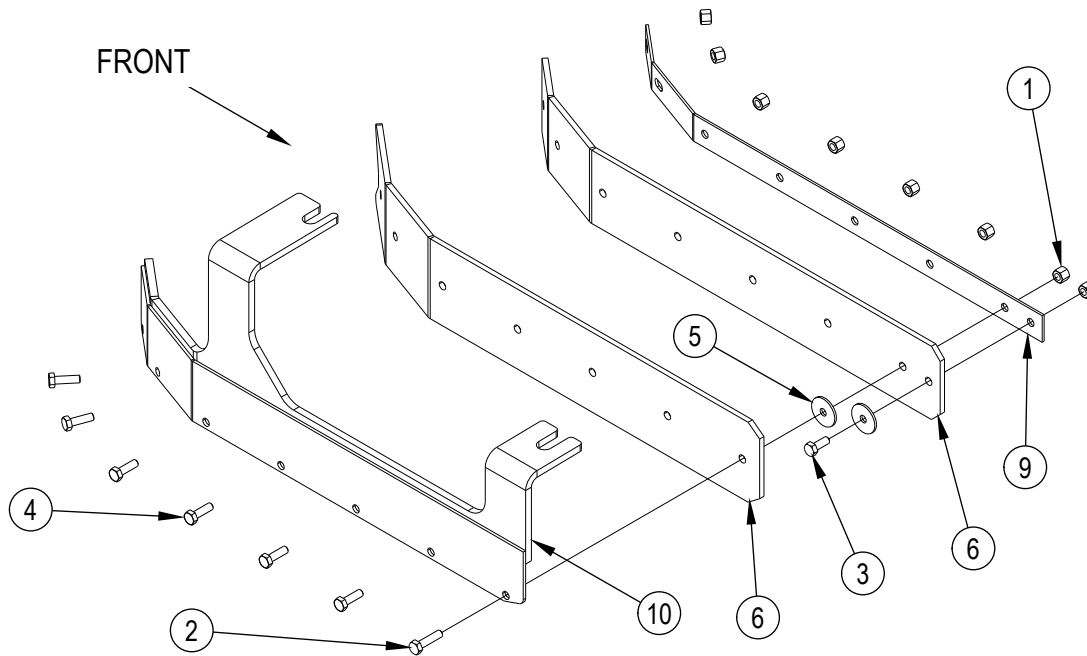

SCRUB SYSTEM-CYLINDRICAL SKIRT ASSEMBLIES

Item	Ref. No.	Qty	Description
	56601468	1	Left Skirt Assy (1-8)
	56601476	1	Right Skirt Assy (1-6, 9, 10)
1	56003426	8	Nut, Hex Nyl Loc SS M6-1
2	56003430	1	Scr, Hex SS M6-1 X 25mm
3	56003431	1	Scr, Hex SS M6-1 X 16mm
4	56003454	6	Scr, Hex Thd To Hd SS M6-1 X 20mm
5	56009060	2	Wsh, Flt SS .260 X 1.000 X .074
6	56316194	1	Blade Kit-Gum NOTE 2
*	56601538	1	Blade Kit-PU Cyl NOTE 2
*	56601681	1	Blade Kit-Red Gum NOTE 2
7	56601047	1	Skirt Bracket Weld't (Left)
8	56601046	1	Retainer, Skirt (Left)
9	56601045	1	Retainer, Skirt (Right)
10	56601044	1	Skirt Bracket Weld't (Right)

* = Optional, Not Included

NOTE 1: Quantities shown for items 1-7 are for one skirt assembly. There are two skirt assemblies on the machine.

NOTE 2: All deck blade kits include all blades necessary.

SCRUB SYSTEM-DISK BR755

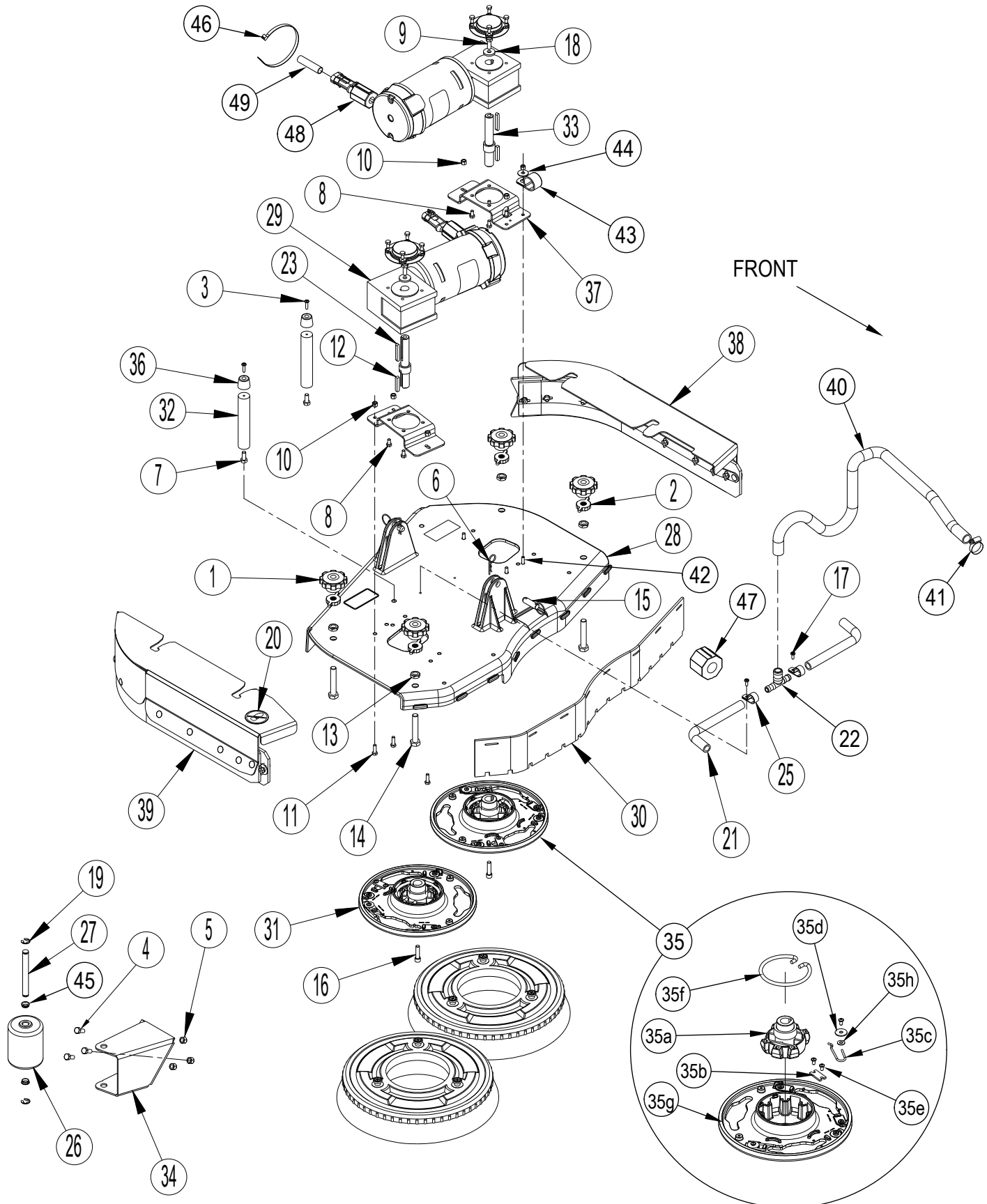

SCRUB SYSTEM-DISK BR755

Item	Ref. No.	Qty	Description	Item	Ref. No.	Qty	Description
1	56380149	4	Knob TSBUS2010-1060	29	56601134	2	Motor Gearbox Assy (M7 / M8)
2	56601578	4	Knob	[]	56601533	1	Gearbox
3	56002192	2	Scr. Pan Phil 10-24 X .75	[]	56314580	1	Bearing (fan end)
4	56002667	3	Scr. Hex 5/16-18 X .75	[]	56601537	1	Bearing (brush end)
5	56002701	3	Nut, Hex Nyl Loc 5/16-18	[]	56601534	2	Carbon Brush
6	56002959	2	Pin, Cotter Hair	[]	56601535	1	Key-6mm Square
7	56003012	2	Scr. Hex SS 5/16-18 X .75	[]	56601508	1	Brush Motor Cover
8	56003211	8	Scr. Hex SS M6-1 X 12mm	[]	56601536	1	Motor Fan
9	56003335	2	Scr. Hex Loc SS 5/16-18 X .88	30	56601248	1	Blade-Front Gum
10	56003426	6	Nut, Hex Nyl Loc SS M6-1	*	56601521	1	Blade-Front PU
11	56003454	5	Scr. Hex Thd To Hd SS M6-1 X 20mm	31	56601733	1	Brush Plate Assy NOTE 1
12	56003526	2	Key, Square .25 X 1.44	32	56601289	2	Rod, Up Stop
13	56003657	4	Nut, Hex Jam SS M12-1.75	33	56601319	2	Shaft, Hub Mount
14	56003658	4	Scr. Hex Thd To Hd SS M12-1.75 X 70mm	34	56601032	1	Roller Brkt 28
15	56003786	2	Pin, Ring .500 X 1.18	35	56601734	1	Brush Plate Assy
16	56003798	2	Scr. Soc Hd 5/16-18 X 1.25 Zinc Plated	35a	56112521	1	Gimbal Assy
17	56009029	2	Scr. Pan Phil Thd Form 10-24 X .50	35b	56366455	1	Plate, Stop
18	56009057	2	Wsh, Flt Harden .344x1.000x.120/.135	35c	56109653	2	Spring Retainer
19	56003264	2	Ring-Ret Ext Type E .50 Dia	35d	56009002	2	Wsh, Flt .266 X .906 X .060
20	56016163	1	Decal, No Step	35e	56009247	3	Scr. Pan Phil Plastite 10-14 X .38
21	56266108	2	Hose, Spiral .500	35f	56601056	1	Spring, Brush Holder
22	56305760	1	Tee, Barb 3/4 X 1/2 X 1/2	35g	56601118	1	Brush Plate
23	56314359	2	Key, 6mm Sq	35h	56002053	1	Wsh, Flt STD #10
25	56328064	2	Clamp,P	36	56601388	2	Up Stop Mount
26	56407006	1	Wheel, Roller	37	56601389	2	Bracket, Motor
27	56601580	1	Pin	38	56601541	1	Skirt Assembly Lt 28 NOTE 4
28	56601113	1	Scrub Deck, Cast		56383471	1	Skirt Assy-Left-28D NOTE 5
				39	56601543	1	Skirt Assembly Rt NOTE 4
					56383470	1	Skirt Assy-Right-28-34D NOTE 5
				40	56601793	1	Hose-.75X36.00
				41	56244969	1	Clamp-Hose SAE 12
				42	56003695	1	Scr. Hex Thd To Hd SS M6-1 X 25mm
				43	56409463	1	Clamp-1.25 Hose Support
				44	56003696	1	Wsh-Flt SS .33 X 1.00 X.060
				45	56302164	2	Nylon Bearing
				46	56477613	1	Tie-Cable
				47	56601687	1	Ferrite Bead NOTE 2
				48	56601686	2	Ferrite Bead NOTE 3
				49	56384077	2	Sleeve-Braided-2.00x.50id NOTE 6

* = Optional, Not Included

[] = Not Shown

NOTE 1: Item 31 (56601733) consists of the exact same components as item 35 (56601734).

NOTE 2: Installed on main harness.

NOTE 3: Installed on each brush drive motor.

NOTE 4: The original Skirt Assemblies have been reactivated and are available again. **If you have a machine built before January 20, 2014 and After April 13, 2015** and you need to replace either skirt assembly you should order **Skirt Assy Kit 56384427** for BR755 models and replace them as a matched pair. **See pages 20 and 21.**

NOTE 5: The Side Skirt Assemblies were updated as of January 20, 2014. **If you have a machine built between January 20, 2014 and April 13, 2015** and you need to replace either skirt assembly you should order **Skirt Assy Kit 56383468** for BR755 models and replace them as a matched pair. **See pages 22 and 23.** If you want to replace either Skirt Assembly with the original Side Skirt Assemblies you should order **Skirt Assy Kit 56384427** for BR755 models and replace them as a matched pair. **See pages 20 and 21.**

NOTE 6: 56384077 is only used on machines built after January 26th 2015.

SCRUB SYSTEM-DISK BR855

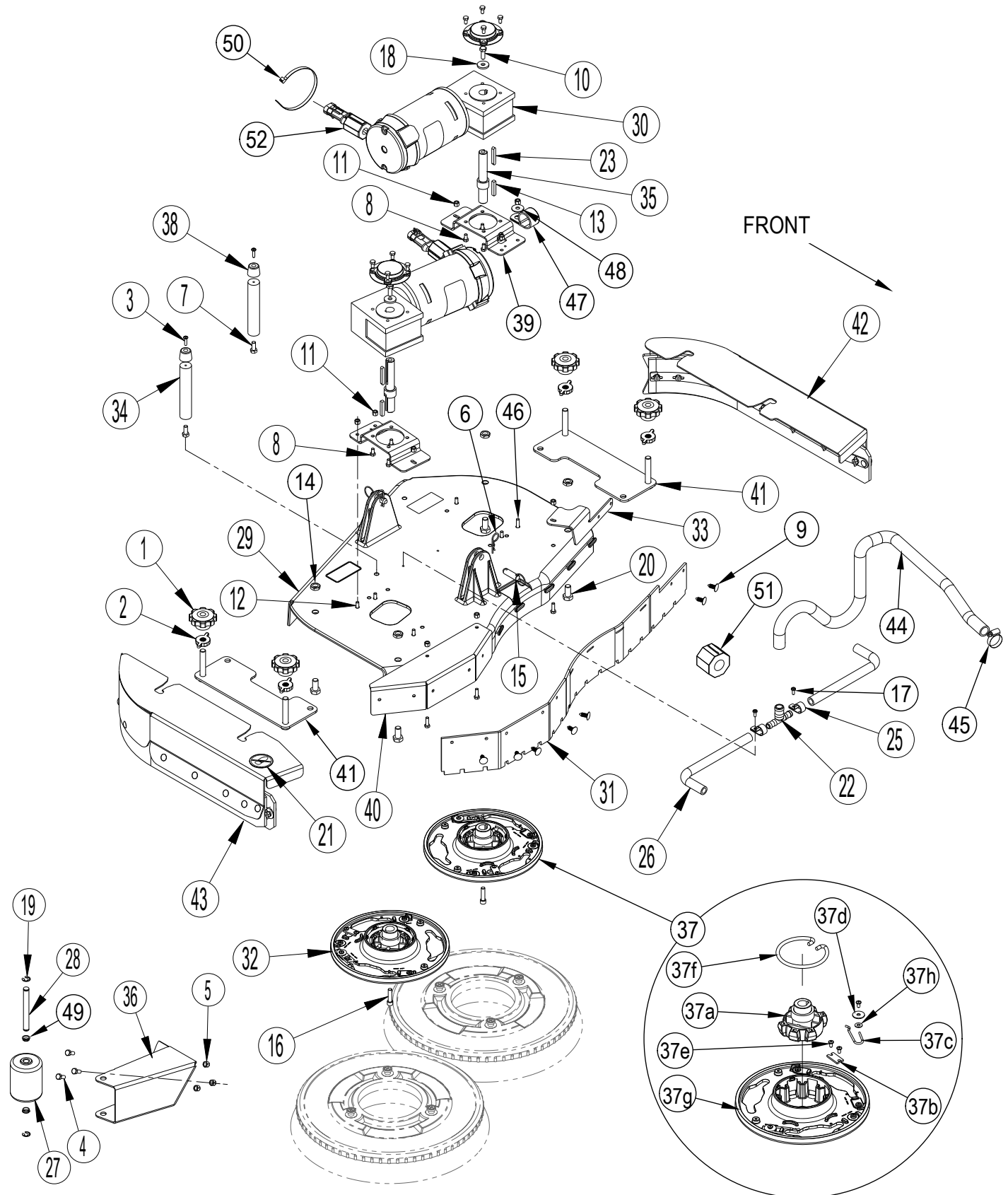

SCRUB SYSTEM-DISK BR855

Item	Ref. No.	Qty	Description
1	56380149	4	Knob TSBUS2010-1060
2	56601578	4	Knob
3	56002192	2	Scr. Pan Phil 10-24 X .75
4	56002667	3	Scr. Hex 5/16-18 X .75
5	56002701	3	Nut, Hex Nyl Loc 5/16-18
6	56002959	2	Pin, Cotter Hair
7	56003012	2	Scr. Hex SS 5/16-18 X .75
8	56003211	8	Scr. Hex SS M6-1 X 12mm
9	56003263	7	Rivet, Nylon Tree Push-In (.25)
10	56003335	2	Scr. Hex Loc SS 5/16-18 X .88
11	56003426	9	Nut, Hex Nyl Loc SS M6-1
12	56003454	8	Scr. Hex Thd To Hd SS M6-1 X 20mm
13	56003526	2	Key, Square .25 X 1.44
14	56003657	4	Nut, Hex Jam SS M12-1.75
15	56003786	2	Pin, Ring .500 X 1.18
16	56003798	2	Scr. Soc Hd 5/16-18 X 1.25 Zinc Plated
17	56009029	2	Scr. Pan Phil Thd Form 10-24 X .50
18	56009057	2	Wsh, Flt Harden .344x1.000x.120/.135
19	56003264	2	Ring-Ret Ext Type E .50 Dia
20	56009119	4	Scr. Hex Thd To Hd M12-1.75 X 25mm
21	56016163	1	Decal, No Step
22	56305760	1	Tee, Barb 3/4 X 1/2 X 1/2
23	56314359	2	Key, 6mm Sq
25	56328064	2	Clamp,P
26	56387302	2	Hose, Spiral .500
27	56407006	1	Wheel, Roller
28	56601580	1	Pin
29	56601113	1	Scrub Deck, Cast

Item	Ref. No.	Qty	Description
------	----------	-----	-------------

30	56601134	2	Motor Gearbox Assy (M7 / M8)
[]	56601533	1	Gearbox
[]	56314580	1	Bearing (fan end)
[]	56601537	1	Bearing (brush end)
[]	56601534	2	Carbon Brush
[]	56601535	1	Key-6mm Square
[]	56601508	1	Brush Motor Cover
[]	56601536	1	Motor Fan
31	56601275	1	Blade-Front Gum
*	56601522	1	Blade-Front PU
32	56601733	1	Brush Plate Assy NOTE 1
33	56601278	1	Skirt Bracket, Front 34
34	56601289	2	Rod, Up Stop
35	56601319	2	Shaft, Hub Mount
36	56601031	1	Roller Brkt 34
37	56601734	1	Brush Plate Assy
37a	56112521	1	Gimbal Assy
37b	56366455	1	Plate, Stop
37c	56109653	2	Spring Retainer
37d	56009002	1	Wsh, Flt .266 X .906 X .060
37e	56009247	4	Scr. Pan Phil Plastite 10-14 X .38
37f	56601056	1	Spring, Brush Holder
37g	56601118	1	Brush Plate
37h	56002053	1	Wsh, Flt STD #10
38	56601388	2	Up Stop Mount
39	56601389	2	Bracket, Motor
40	56601452	1	Brush Cover
41	56601034	2	Side Skirt Weldment
42	56601542	1	Skirt Assembly Lt 34 NOTE 4
	56383472	1	Skirt Assy-Left-34D NOTE 5
43	56601543	1	Skirt Assembly Rt NOTE 4
	56383470	1	Skirt Assy-Right-28-34D NOTE 5
44	56601793	1	Hose-.75X36.00
45	56244969	1	Clamp-Hose SAE 12
46	56003695	1	Scr. Hex Thd To Hd SS M6-1 X 25mm
47	56409463	1	Clamp-1.25 Hose Support
48	56003696	1	Wsh-Flt SS .33 X 1.00 X.060
49	56302164	2	Nylon Bearing
50	56477613	1	Tie-Cable
51	56601687	1	Ferrite Bead NOTE 2
52	56601686	2	Ferrite Bead NOTE 3

* = Optional, Not Included

[] = Not Shown

NOTE 1: Item 32 (56601733) consists of the exact same components as item 37 (56601734).

NOTE 2: Installed on main harness.

NOTE 3: Installed on each brush drive motor.

NOTE 4: The original Skirt Assemblies have been reactivated and are available again. **If you have a machine built before January 20, 2014 and After April 13, 2015** and you need to replace either skirt assembly you should order **Skirt Assy Kit 56384428 for BR855 models** and replace them as a matched pair. **See pages 20 and 21.**

NOTE 5: The Side Skirt Assemblies were updated as of January 20, 2014. **If you have a machine built between January 20, 2014 and April 13, 2015** and you need to replace either skirt assembly you should order **Skirt Assy Kit 56383469 for BR855 models** and replace them as a matched pair. **See pages 22 and 23.** If you want to replace either Skirt Assembly with the original Side Skirt Assemblies you should order **Skirt Assy Kit 56384428 for BR855 models** and replace them as a matched pair. **See pages 20 and 21.**

**SCRUB SYSTEM-DISK SKIRT ASSEMBLIES
BEFORE JANUARY 20 2014 AND AFTER APRIL 13 2015**

56601541 (BR755) / 56601542 (BR855) - Left Skirt Assy

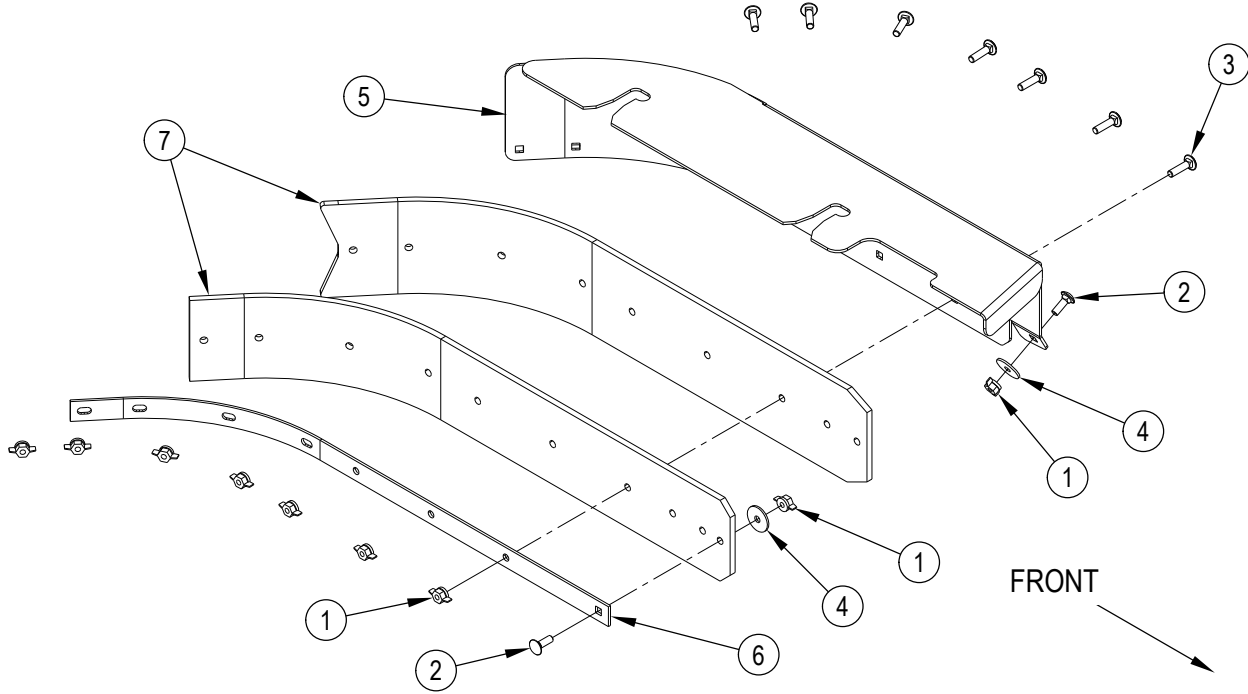

56601543 - Right Skirt Assy

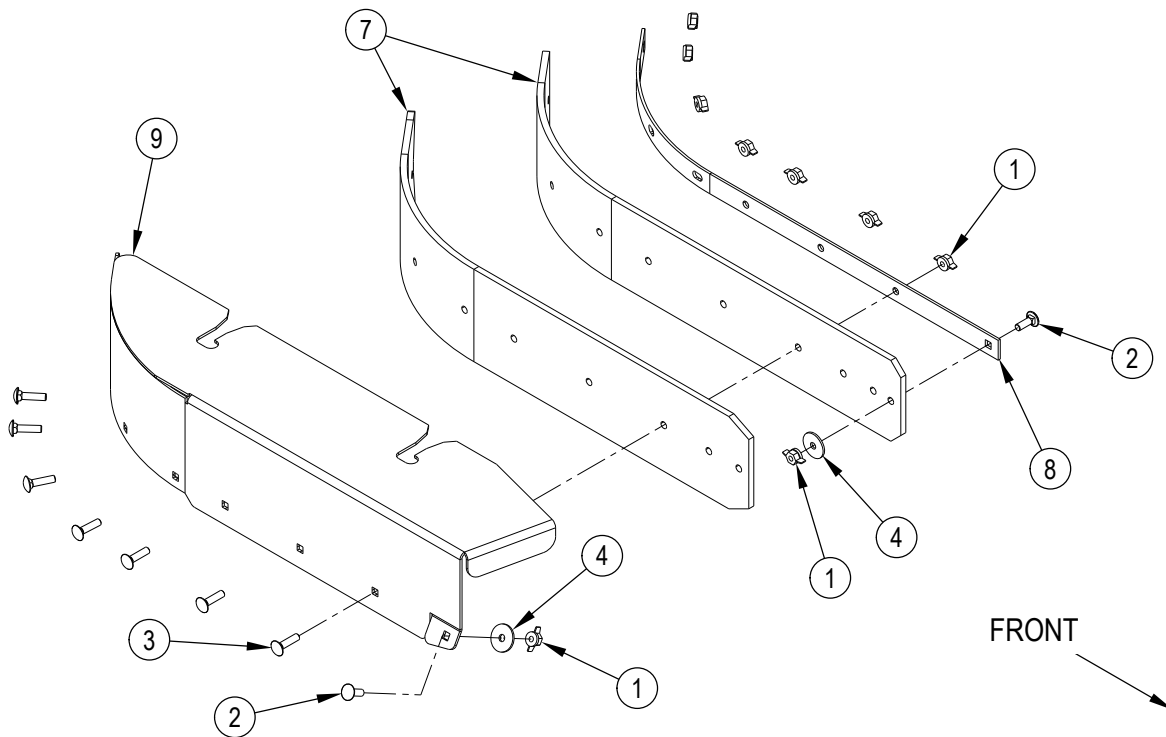

**SCRUB SYSTEM-DISK SKIRT ASSEMBLIES
BEFORE JANUARY 20 2014 AND AFTER APRIL 13 2015**

Item	Ref. No.	Qty	Description
	56601541	1	Left Skirt Assy (BR 755 / 1-8) NOTE 3
	56601542	1	Left Skirt Assy (BR 855 / 1-8) NOTE 3
	56601543	1	Right Skirt Assy (All Models / 1-4, 7, 8, 9) NOTE 3
1	56003824	9	Nut-Wing Plastic Loc 1/4-20
2	56003715	2	Scr-Carriage SS 1/4-20 x .75
3	56003828	7	Scr-Carriage SS 1/4-20 x 1.00
4	56009060	2	Wsh Flt SS .260X1.000X.074
5	56601043	1	Frame, Skirt Lh 28 (BR 755 / Left)
[]	56601042	1	Frame, Skirt Lh 34 (BR 855 / Left)
6	56601040	1	Retainer, Skirt (BR 755 / Left)
[]	56601039	1	Retainer, Skirt (BR 855 / Left)
7	56383488	1	Skirt Blade Kit-Gum NOTE 2
*	56383490	1	Skirt Blade Kit-PU NOTE 2
*	56383489	1	Skirt Blade Kit-Red Gum NOTE 2
8	56601040	1	Retainer, Skirt (All Models / Right)
9	56601041	1	Frame, Skirt Rh (All Models / Right)

* = Optional, Not Included

NOTE 1: All quantities shown are for one skirt assembly. There are two skirt assemblies on the machine.

NOTE 2: All disk deck blade kits include all side skirt blades.

NOTE 3: The original Skirt Assemblies have been reactivated and are available again. If you have a machine built before January 20, 2014 and After April 13, 2015 and you need to replace either skirt assembly you should order Skirt Assy Kit 56384427 for BR755 models or Skirt Assy Kit 56384428 for BR855 models and replace them as a matched pair.

**SCRUB SYSTEM-DISK SKIRT ASSEMBLIES
BETWEEN JANUARY 20 2014 AND APRIL 13 2015**

56383471 (BR755) / 56383472 (BR855) - Left Skirt Assy

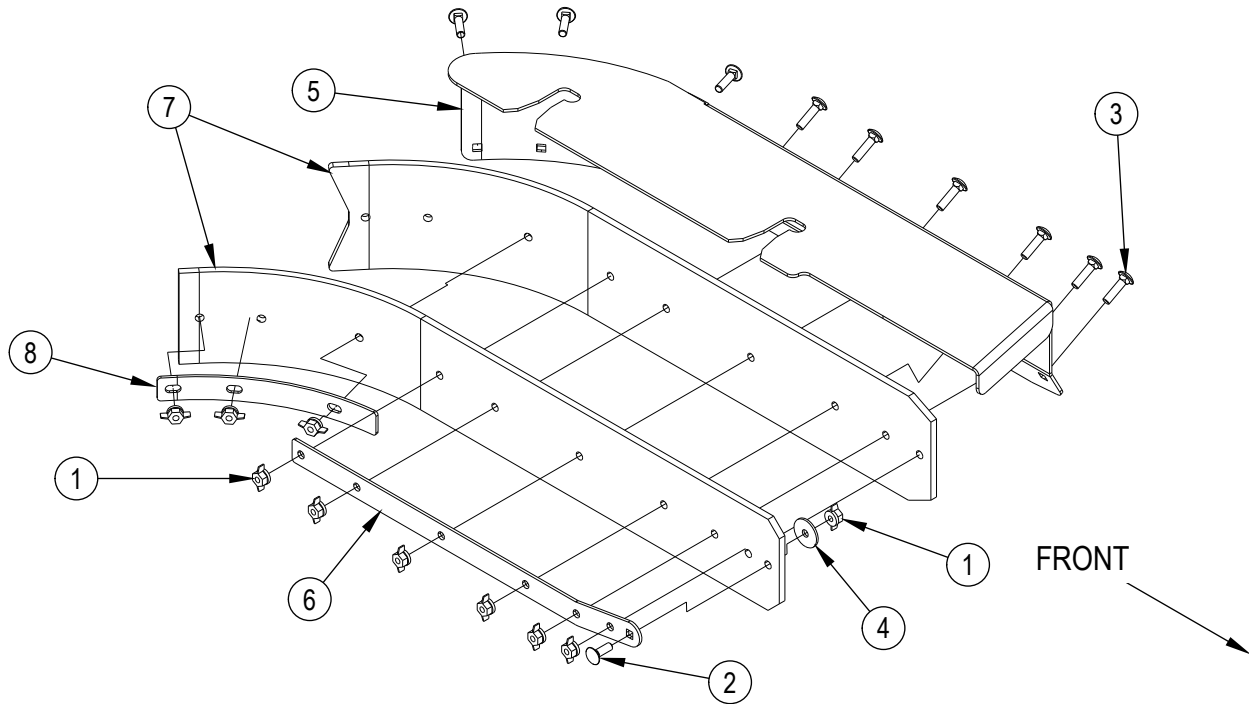

56383470 - Right Skirt Assy

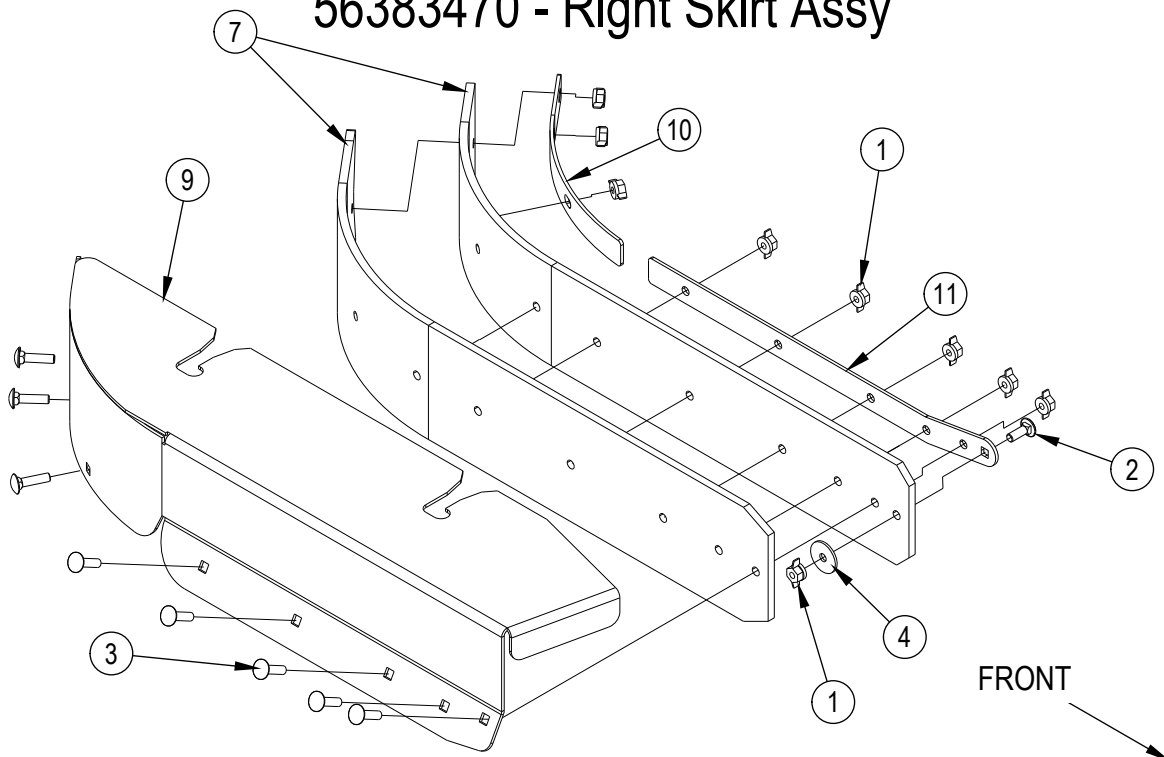

SCRUB SYSTEM-DISK SKIRT ASSEMBLIES BETWEEN JANUARY 20 2014 AND APRIL 13 2015

Item	Ref. No.	Qty	Description
	56383471	1	Skirt Assy-Left-28D (BR755 / 1-8) NOTE 3
	56383472	1	Skirt Assy-Left-34D (BR855 / 1-8) NOTE 3
	56383470	1	Skirt Assy-Right-28-34D (All Models / 1-4, 7, 9, 10, 11) NOTE 3
1	56003824	9	Nut-Wing Plastic Loc 1/4-20 (qty of 10 in 56383472)
2	56003715	1	Scr-Carriage SS 1/4-20 x .75
3	56003828	8	Scr-Carriage SS 1/4-20 x 1.00 (qty of 9 in 56383472)
4	56009060	1	Wsh Flt SS .260X1.000X.074
5	56383492	1	Skirt Bkt Weldt-Left-28D (BR755 / Left)
5	56383493	1	Skirt Bkt Weldt-Left-34D (BR855 / Left)
6	56383473	1	Strap-Front-28-34D (BR755 / Left)
6	56383474	1	Strap-Front-Left-34D (BR855 / Left)
7	56383488	1	Skirt Blade Kit-Gum NOTE 2
*	56383490	1	Skirt Blade Kit-PU NOTE 2
*	56383489	1	Skirt Blade Kit-Red Gum NOTE 2
8	56114386	1	Strap Rear 28D 34D (BR755 / Left)
8	56114387	1	Strap Rear 34D LT (BR855 / Left)
9	56383491	1	Skirt Bkt Weldt-Right-28-34D (All Models / Right)
10	56114386	1	Strap Rear 28D 34D (All Models / Right)
11	56383473	1	Strap-Front-28-34D (All Models / Right)

* = Optional, Not Included

NOTE 1: All quantities shown are for one skirt assembly. There are two skirt assemblies on the machine.

NOTE 2: All disk deck blade kits include all side skirt blades.

NOTE 3: The Side Skirt Assemblies were updated as of January 20, 2014. If you have a machine built between January 20, 2014 and April 13, 2015 and you need to replace either skirt assembly you should order **Skirt Assy Kit 56383468 for BR755 models** or **Skirt Assy Kit 56383469 for BR855 models** and replace them as a matched pair. If you want to replace either Skirt Assembly with the original Side Skirt Assemblies you should order **Skirt Assy Kit 56384427 for BR755 models** or **Skirt Assy Kit 56384428 for BR855 models** and replace them as a matched pair. See pages 20 and 21.

SOLUTION SYSTEM

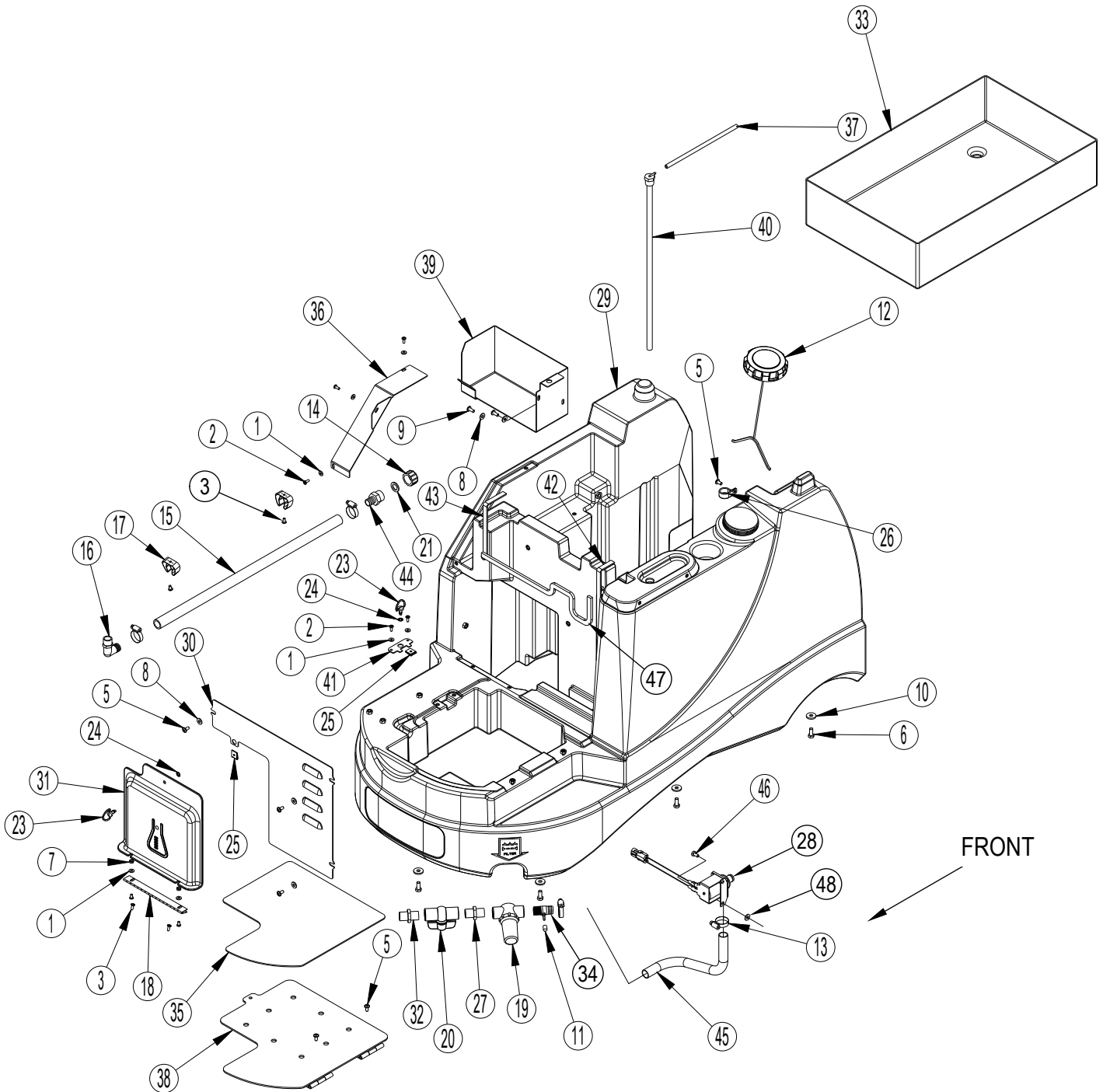

SOLUTION SYSTEM

Item	Ref. No.	Qty	Description
1	56002916	7	Wsh Flt SAE SS 10
2	56003400	5	Scr Pan Phil SS Loc 10-24x.50
3	56003913	6	Scr-Pan Phil Loc SS 10-24x.38
5	56003119	8	Scr Pan Phil SS 1/4-20 X .50
6	56002667	4	Scr, Hex 5/16-18 X .75
7	56002849	2	Nut Hex Nyl Loc-Thin SS 10-24
8	56002859	5	Wsh, Flt Sae Ss 1/4
9	56002989	2	Scr, Pan Phil SS 1/4-20 X .62
10	56009122	4	Wsh, Flt .344 X .938 X .125
11	56051209	1	Rubber Tip-Black
12	56510442	1	Cap-Extra Vent TSB-FC-2015-031
13	56244969	4	Clamp, Hose SAE #12
14	56255076	1	Cap, Pipe Ght Nylon
15	56261265	1	Hose, .75 Clear Pvc, 25.00
16	56314757	1	Barb, 90 Elbow 3/4 X 1/2npt
17	56601598	1	Hose Clip
18	56315285	1	Hinge
19	56315296	1	Solution Filter
*	56601594	1	Solution Filter Kit (includes O-Ring, Mesh Filter & Filter Housing)
20	56381475	1	Ball Valve
21	56368776	1	Washer, Rubber
23	56380132	2	Latch, 1/4 Turn
24	56380137	2	Retainer
25	56380141	2	Nut, Clamp
26	56410097	3	Clamp, P
27	56412182	2	Coupling-1/2npt To 1/2npt
28	56601064	1	Solenoid Valve Assy TSB-FC-2015-023
29	56601076	1	Solution Tank
30	56601106	1	Panel
31	56601202	1	Chemcial Bottle Cover
32	56601212	1	Nipple Reducer NOTE 1
33	56601213	1	Battery Box
34	56601236	1	Tee, Special,3/4 X 3/16 X 1/2npt
35	56601246	1	Mat
36	56601268	1	Plate
37	56112553	1	Hose
38	56601339	1	Charger Cover Weldt
39	56601845	1	Bracket
40	56344172	1	Tube-Pressure Sensing W/Elbow
41	56601843	1	Plate
42	56601569	1	Gasket
43	56601570	1	Gasket
44	56900273	1	Barb, Adapter 3/4 X 3/4ght
45	30445A	1	Hose, Solution
46	56002935	1	Scr Hex Loc Ss 1/4-20 X .75
47	56601685	1	Gasket
48	56009064	1	Wsh Int Shprf 1/4

* = Optional, Not Included

NOTE 1: 56601212 is only used on machines built before December 16, 2013. After that date it is replaced with 56412182.

SQUEEGEE SYSTEM

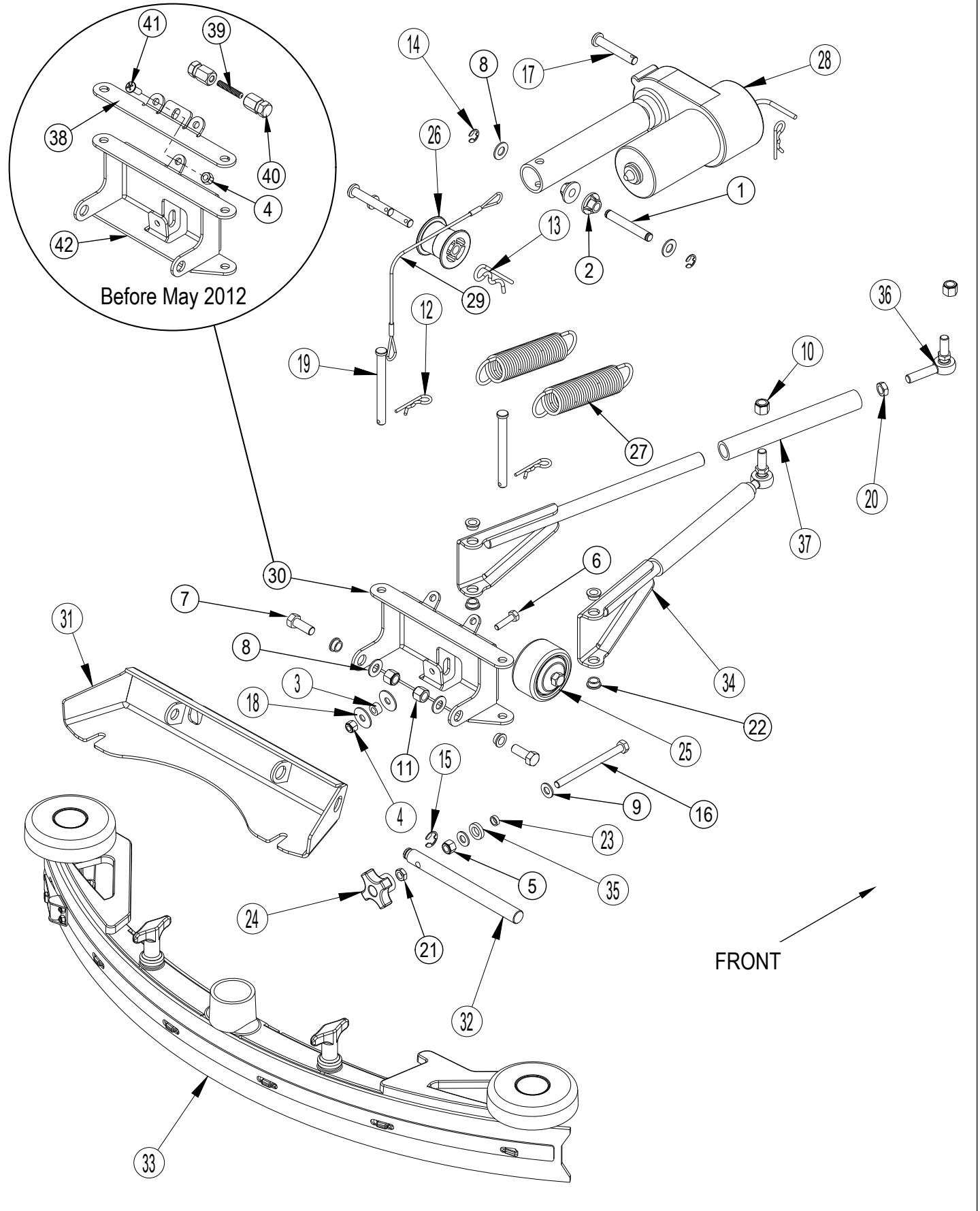

SQUEEGEE SYSTEM

Item	Ref. No.	Qty	Description
1	56412088	1	Pin
2	56412248	2	Spacer, Squeegee Cable
3	56453691	1	Spacer
4	56002491	2	Nut, Hex Nyl Loc SS 1/4-20 NOTE 1
5	56002856	1	Nut, Hex Nyl Loc SS 5/16-18
6	56002883	1	Scr, Hex SS 1/4-20 X 1.00
7	56002886	2	Scr, Hex SS 3/8-16 X 1.00
8	56002910	4	Wsh, Flt SAE SS 3/8
9	56002938	2	Wsh, Flt SAE SS 5/16
10	56002951	2	Nut, Hex Nyl Loc 3/8-24
11	56003219	2	Nut, Hex Nyl Loc SS 3/8-16
12	56003222	3	Pin, Cotter Hair
13	56003223	1	Pin, Cot Hair .148 X Dia .62/1.00
14	56003262	2	Ring, Ret Ext Type E 0.38 Dia
15	56003264	1	Ring, Ret Ext Type E 0.50 Dia
16	56003486	1	Scr, Hex Thd To Hd SS 5/16-18 X 4.00
17	56003656	3	Pin, Clevis .375 X 2.25
18	56003696	2	Wsh, Flt SS .33 X 1.00 X.060
19	56003713	2	Pin, Clevis .38 X 3.75
20	56009103	2	Nut, Hex Jam 3/8-24
21	56009141	1	Nut, Hex Jam SS 5/16-18
22	56324505	6	Bearing, Flange
23	56381818	1	Bushing .32x.44x.15
24	56407303	1	Knob
25	56412124	1	Wheel
26	56412208	1	Roller
27	56412216	2	Spring, Extension NOTE 1
28	56601147	1	Actuator, Motor 24v (M3)
29	56601257	1	Cable Assembly
30	56601038	1	Weldt-Squeegee Pivot NOTE 2
31	56601037	1	Weldt-Squeegee Mount
32	56601442	1	Shaft
33	56601449	1	Squeegee Assy (BR 755) (Includes Gum Rubber Blades)
	56601454	1	Squeegee Assy (BR 855) (Includes Gum Rubber Blades)
34	56601460	2	Bar Weldment
35	56601463	1	Washer, Polyurethane
36	56601469	2	Rod End
37	56601512	2	Hose
38	56382623	1	Bracket-Spring Advenger NOTE 1
39	56382637	1	Rod-Threaded .25 X 1.25 NOTE 1
40	56382624	2	Nut-Spring NOTE 1
41	56002957	1	Scr Pan Phil SS 1/4-20 X .75 NOTE 1
42	56601436	1	Squeegee Pivot Bracket Weld't NOTE 3

NOTE 1: These parts were implemented in production as of November 2011 to increase squeegee down pressure. Order Squeegee Spring Kit 56382635 to upgrade your machine to include this improvement. Only used before May 2012.

NOTE 2: After April 2012.

NOTE 3: Before May 2012.

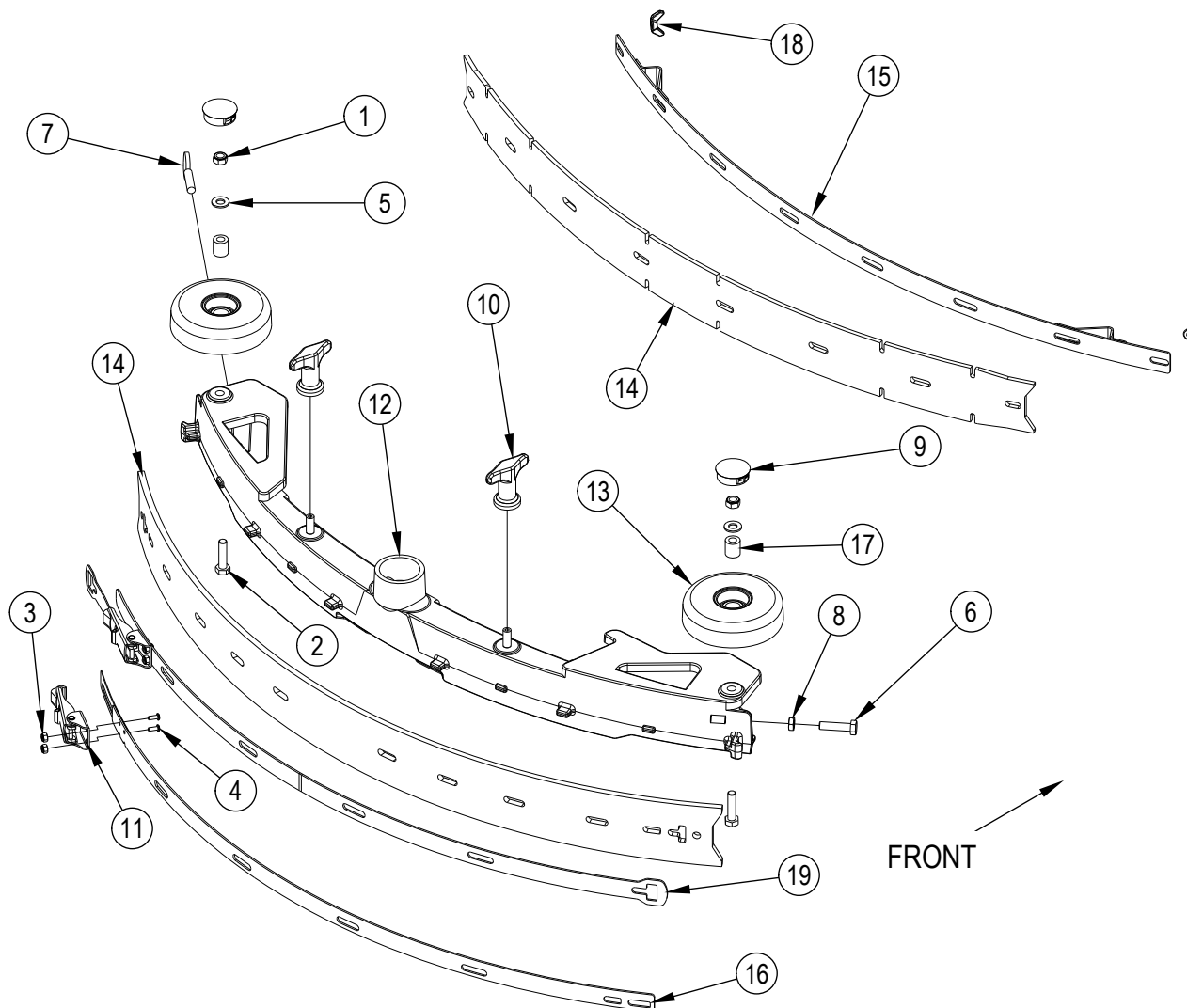

SQUEEGEE ASSY-BR755

Item	Ref. No.	Qty	Description	Item	Ref. No.	Qty	Description
	56601449	1	Squeegee Assembly (Includes Gum Rubber Blades)	13	56601450	2	Wheel, 4.00 Od
1	56002851	2	Nut, Hex Nyl Loc-Thin SS 5/16-18	14	56382734	1	Blade Kit-Squeegee-Gum 28 After October 2011 NOTE 1 / NOTE 5
2	56003302	2	Scr Hex Thd/Hd SS 5/16-18X1.25		56601744	1	Blade Kit-Squeegee-Gum 28 Before November 2011 NOTE 1
3	56002907	2	Nut, Hex Nyl Loc SS 6-32 Before June 2012	*	56382737	1	Blade Kit-Squeegee-PU 28 After October 2011 / NOTE 1 / NOTE 5
4	56002909	2	Scr. Pan Phil SS 6-32 X .38 Before June 2012	*	56601745	1	Blade Kit, Squeegee PU Before November 2011 / NOTE 1
5	56002938	2	Wsh, Flt SAE SS 5/16	*	56382735	1	Blade Kit-Squeegee-Red Gum 28 After October 2011 NOTE 1 / NOTE 5
6	56003302	1	Scr. Hex Thd To Hd SS 5/16-18 X 1.25	*	56601746	1	Blade Kit, Squeegee Red Gum Before November 2011 NOTE 1
7	56003792	1	Scr. Thumb SS 5/16-18 X 1.25	15	56601489	1	Front Strap Weldment
8	56009141	1	Nut, Hex Jam SS 5/16-18	16	56601591	1	Strap, Rear NOTE 3
9	56111444	2	Button Plug-1.25		56382676	1	Strap, Rear NOTE 4
10	56370711	2	Nut, Thumb	17	56601499	2	Bushing, Nylon
11	56471194	1	Latch Before June 2012	18	56009111	2	Nut-Wing SS 1/4-20 NOTE 3
12		1	Squeegee Casting NOTE 2	19	56382697	1	Clamp-Band 28 In Assy After May 2012

* = Optional, Not Included

NOTE 1: All squeegee blade kits include both front and rear squeegee blades.

NOTE 2: The squeegee casting is not available for sale separately. If you need to replace your squeegee casting please order a new Squeegee Assembly part number 56601449.

NOTE 3: TSBUS2009-1041 - Only used before SN 3000023100.

NOTE 4: TSBUS2009-1041 - Only used after SN 3000023099 and before June 2012.

NOTE 5: These squeegee blades are designed to provide increased performance and reduced streaking. When installing these blades on a machine built before November 2011 you must also order a new rear strap part number 56382676.

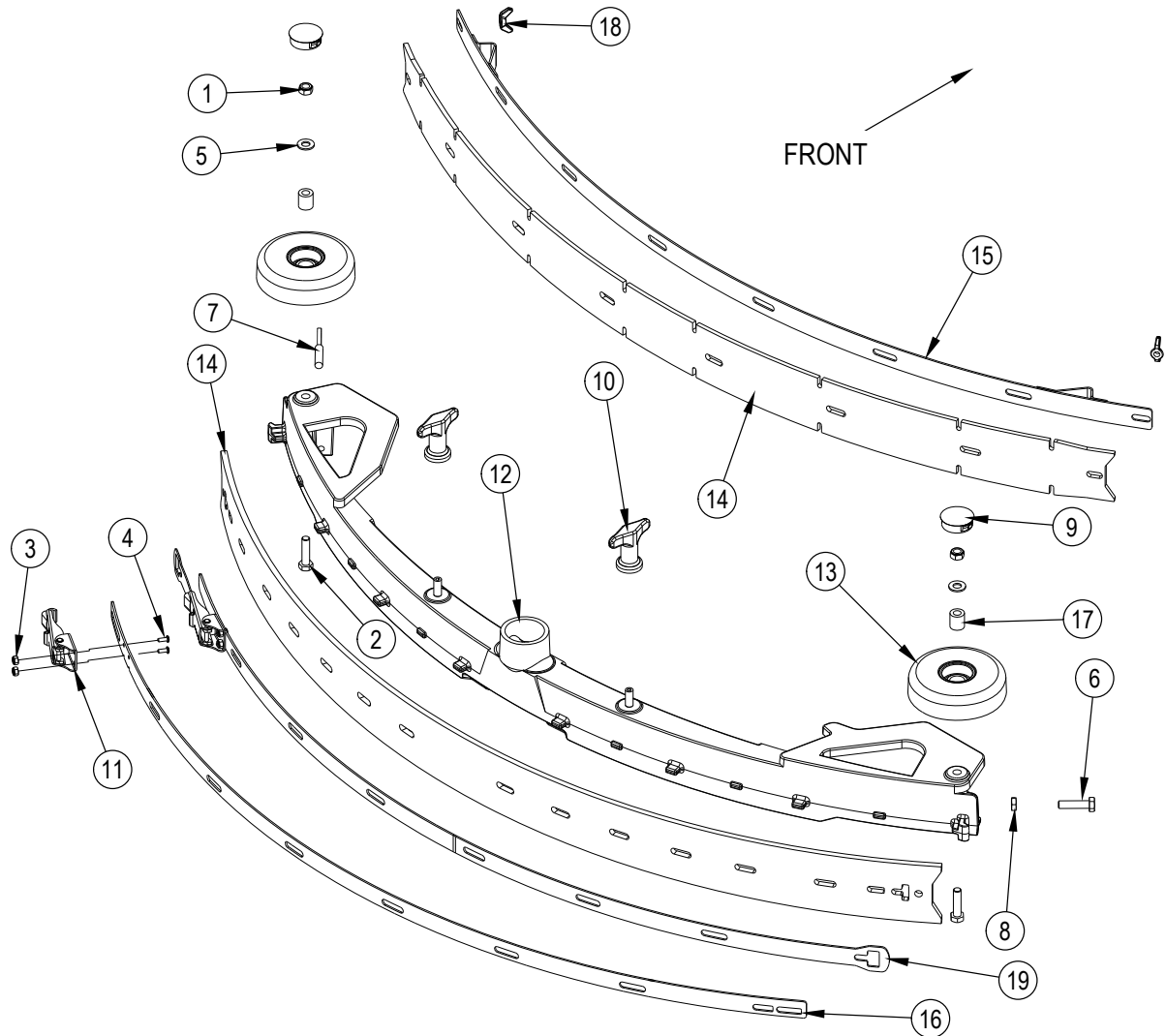

SQUEEGEE ASSY-BR855

Item	Ref. No.	Qty	Description
	56601454	1	Squeegee Assembly (Includes Gum Rubber Blades)
1	56002851	2	Nut, Hex Nyl Loc-Thin SS 5/16-18
2	56003302	2	Scr Hex Thd/Hd SS 5/16-18X1.25
3	56002907	2	Nut, Hex Nyl Loc SS 6-32 Before May 2012
4	56002909	2	Scr, Pan Phil SS 6-32 X .38 Before May 2012
5	56002938	2	Wsh, Fit SAE SS 5/16
6	56003302	1	Scr, Hex Thd To Hd SS 5/16-18 X 1.25
7	56003792	1	Scr, Thumb SS 5/16-18 X 1.25
8	56009141	1	Nut, Hex Jam SS 5/16-18
9	56111444	2	Button Plug-1.25
10	56370711	2	Nut, Thumb

Item	Ref. No.	Qty	Description
11	56471194	1	Latch Before May 2012
12		1	Squeegee Casting NOTE 2
13	56601450	2	Wheel, 4.00 Od
14	56382738	1	Blade Kit-Squeegee-Gum 34 NOTE 1
*	56382740	1	Blade Kit-Squeegee-PU 34 NOTE 1
*	56382739	1	Blade Kit-Squeegee-Red Gum 34 NOTE 1
15	56601495	1	Front Strap Weldment (34")
16	56601496	1	Strap, Rear NOTE 4
	56601593	1	Strap, Rear NOTE 3
17	56601499	2	Bushing, Nylon
18	56009111	2	Nut-Wing SS 1/4-20 NOTE 3
19	56382698	1	Clamp-Band 34 In Assy After April 2012

* = Optional, Not Included

NOTE 1: All squeegee blade kits include both front and rear squeegee blades.

NOTE 2: The squeegee casting is not available for sale separately. If you need to replace your squeegee casting please order a new Squeegee Assembly part number 56601454.

NOTE 3: TSBUS2009-1041 - Only used before SN 300006847.

NOTE 4: TSBUS2009-1041 - Only used after SN 300006846 and before May 2012.

LADDER DIAGRAM

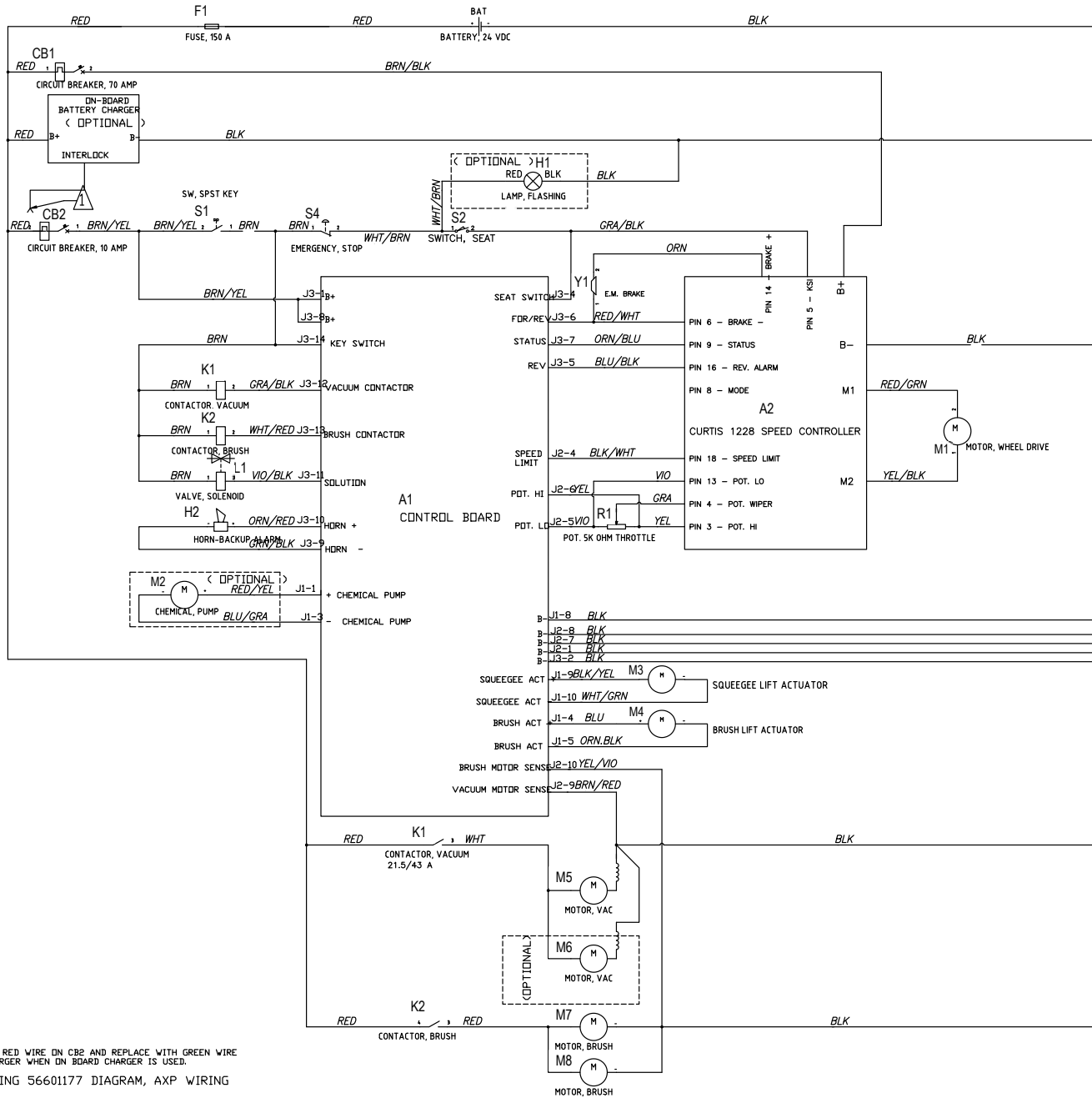

NOTES:
 ⚠ DISCONNECT RED WIRE ON CB2 AND REPLACE WITH GREEN WIRE FROM CHARGER WHEN ON BOARD CHARGER IS USED.
 REF DRAWING 56601177 DIAGRAM, AXP WIRING

LADDER DIAGRAM

Item	Ref. No.	Qty	Description
A1	56601565	1	Control PCB Assy
A2	56601061	1	Controller, Speed
BAT			Battery
F1	56412089	1	Fuse, 150 Amp
CB1	56454429	1	Circuit Breaker, 70 Amp
CB2	56507644	1	Circuit Breaker, 10 Amp
H1	56307166	1	Beacon, Warning (optional)
H2	56412177	1	Horn/Backup Alarm
K1	56601183	1	Contactactor 24v, 100 Amp
K2	56412179	1	Contactactor 24vdc, 100 Amp
L1	56601064	1	Solenoid Valve Assy TSB-FC-2015-023
M1	56601050	1	Motor / Drive Wheel
M2	56315241	1	Pump, Chemical
M3	56601147	1	Actuator, Motor 24v
M4	56601432	1	Lift Actuator Assembly
M5	56601488	1	Motor, Vac 24vdc
M6	56601488	1	Motor, Vac 24vdc (optional)
M7	56315061	1	Motor, 24 Vdc, .5 Hp, 1800 Rpm (cylindrical) TSBUS2010-1058
	56601134	2	Motor Gearbox Assy (disk)
M8	56315061	1	Motor, 24 Vdc, .5 Hp, 1800 Rpm (cylindrical) TSBUS2010-1058
	56601134	2	Motor Gearbox Assy (disk)
R1		1	Part of 56601052
S1	56303553	1	Key Switch
*	56303526	A/R	Replacement Key Set
S2	7-82-00050	1	Switch, Seat
S4	56407130	1	Disconnect, Emergency
Y1	56601507	1	Brake, Electromagnetic
*	56315124	1	Charger, On-Board 24v TSBUS2008-984

* = Optional, Not Included

OPTIONAL KITS & ACCESSORIES

Item	Ref. No.	Qty	Description	Item	Ref. No.	Qty	Description
Kits				BA 855 Disk Scrub Brushes (See Brush Selector Guide)			
*	56397453	1	Kit-Battery Fill Indicator	*	56505780	2	Short Trim Pad Holder
#	DELETED			*	56505195	2	Pad Retainer for 56505750
#	56383188	1	Arm Rest Kit R/H + L/H NOTE 5	*	56505785	2	ProLite
*	56601085	1	Kit-Warning Beacon	*	56505784	2	Prolene
*	56601087	1	Kit-Vacuum Wand With Caddy	*	56505786	2	Union Mix
*	56422162	1	Kit-Seat Belt	*	56505783	2	AgLite Grit 500
*	56601090	1	Kit-Dual Vac Motor Eu	*	56505787	2	MidGrit 240
*	56601080	1	Kit-Onboard Charger TSBUS2008-984	*	56505788	2	MidLite Grit 180
*	56601527	1	Battery Watering Kit	*	56505782	2	Dyna Grit 80
*	56315732	1	Quiq Programmer Kit	*	56505781	2	Magna Grit 46
*	56601082	1	Kit-Ecoflex Onboard Chemical	BA 755 Cylindrical Scrub Brushes (See Brush Selector Guide)			
*	56601735	1	Debris Tray	*	56412191	2	Soft Nylon
*	56601546	A/R	Kit-BR 755 Disk Deck	*	56412192	2	Hard Nylon
*	56601547	A/R	Kit-BR 855 Disk Deck	*	56412046	2	Prolene
*	56601756	A/R	Kit-BR 755 Cylindrical Deck	*	56412193	2	MidLite Grit 180
*	56383697	1	Skirt Ext-Concrete Polish Kit	*	56412194	2	Dyna Grit 80
*	56384137	1	Idler W/O-Ring Kit	*	56412195	2	Magna Grit 46
BR 755 Squeegee Blade Kits							
	56382734	1	Blade Kit-Squeegee-Gum 28 After October 2011 NOTE 1 / NOTE 4				
	56601744	1	Blade Kit-Squeegee-Gum 28 Before November 2011 NOTE 1				
*	56382737	1	Blade Kit-Squeegee-PU 28 After October 2011 / NOTE 1 / NOTE 4				
*	56601745	1	Blade Kit, Squeegee PU Before November 2011 / NOTE 1				
*	56382735	1	Blade Kit-Squeegee-Red Gum 28 After October 2011 NOTE 1 / NOTE 4				
*	56601746	1	Blade Kit, Squeegee Red Gum Before November 2011 NOTE 1				
BR 855 Squeegee Blade Kits							
	56382738	1	Blade Kit-Squeegee-Gum 34 NOTE 1				
*	56382740	1	Blade Kit-Squeegee-PU 34 NOTE 1				
*	56382739	1	Blade Kit-Squeegee-Red Gum 34 NOTE 1				
Disk Deck Blade Kits							
	56383488	1	Skirt Blade Kit-Gum NOTE 2				
*	56383490	1	Skirt Blade Kit-PU NOTE 2				
*	56383489	1	Skirt Blade Kit-Red Gum NOTE 2				
Cylindrical Deck Blade Kits							
	56316194	1	Blade Kit-Gum NOTE 3				
*	56601538	1	Blade Kit-PU NOTE 3				
*	56601681	1	Blade Kit-Red Gum NOTE 3				
Accessories							
*	56383571	A/R	Programmer-User				
*	56383572	A/R	Programmer Cable-Molex				
*	56044419	1	Literature Pack				
BA 755 Disk Scrub Brushes (See Brush Selector Guide)							
*	56505800	2	Short Trim Pad Holder				
*	56505195	2	Pad Retainer for 56505750				
*	56505805	2	ProLite				
*	56505804	2	Prolene				
*	56505806	2	Union Mix				
*	56505803	2	AgLite Grit 500				
*	56505807	2	MidGrit 240				
*	56505808	2	MidLite Grit 180				
*	56505802	2	Dyna Grit 80				
*	56505801	2	Magna Grit 46				

* = Optional, Not Included

NOTE 1: All squeegee blade kits include both front and rear squeegee blades.

NOTE 2: All disk deck blade kits include all side skirt blades.

NOTE 3: All cylindrical deck blade kits include all blades necessary.

NOTE 4: These squeegee blades are designed to provide increased performance and reduced streaking. When installing these blades on a machine built before November 2011 you must also order a new rear strap part number 56382676.

NOTE 5:# Only for 56383187 (seat with plastic seat pan).

= Revised or new since last update

BRUSH SELECTOR GUIDE-DISK

We provide brushes and pad holders that will give you the best possible performance between machine and floor. Following are descriptions of the materials and their applications.

- ProLite:** Bristles are made from light-duty polypropylene for general scrubbing when you do not want to scratch or remove finish from the floor. Recommended for use in place of red pads.
- Prolene:** Polypropylene material for medium-duty scrubbing on concrete, terrazzo and vinyl floor tile. Recommended for use in place of green or blue pads.
- Union Mix:** Medium grade natural fibers for polishing finished floors with standard-speed equipment. Recommended for use in place of white pads.
- AgLite Grit 500:** For light scrubbing when used wet; buffing or polishing when used dry on urethane coated, sealed concrete or other resilient hard surface floors. Recommended for use in place of red or white pads.
- MidGrit 240:** For general purpose scrubbing when you need a lighter action for sealed or unsealed concrete, stone, terrazzo, quarry tile and other resilient hard floor surfaces. Recommended for use in place of green or blue pads.
- MidLite Grit 180:** For general purpose scrubbing of sealed or unsealed concrete, stone, terrazzo, quarry tile and other resilient hard floor surfaces. Recommended for use in place of green or blue pads.
- Dyna Grit 80:** For aggressive, heavy-duty scrubbing or stripping of floors. Recommended for use in place of brown pads.
- Magna Grit 46:** For extreme heavy-duty scrubbing or stripping of floors. This brush has extra large diameter silicon carbide grit impregnated synthetic bristles. Recommended for use in place of black pads.
- Short Trim Pad Holder:** Made with a structural foam block and center ring for correct pad centering. It has a "shower feed" design for getting solution to the floor.

BR 755 BRUSHES

56505800 - Short Trim Pad Holder
 56505195 - Pad Retainer for 56505800
 56505805 - ProLite
 56505804 - Prolene
 56505806 - Union Mix
 56505803 - AgLite Grit 500
 56505807 - MidGrit 240
 56505808 - MidLite Grit 180
 56505802 - Dyna Grit 80
 56505801 - Magna Grit 46

BR 855 BRUSHES

56505780 - Short Trim Pad Holder
 56505195 - Pad Retainer for 56505780
 56505785 - Prolite
 56505784 - Prolene
 56505786 - Union Mix
 56505783 - AgLite Grit 500
 56505787 - MidGrit 240
 56505788 - MidLite Grit 180
 56505782 - Dyna Grit 80
 56505781 - Magna Grit 46

DISC BRUSH APPLICATION GUIDE (SUGGESTION ONLY)

Application	46 Grit	80 Grit	180 Grit	240 Grit	500 Grit	Prolene	Prolite	Union Mix
Stripping:								
Concrete	X	X						
Terrazzo	X	X						
Ceramic/Quarry tile		X						
Vinyl tile		X						
General Scrubbing:								
Concrete	X	X	X	X		X		
Terrazzo			X	X	X	X		
Ceramic/Quarry tile			X	X	X	X		
Marble					X		X	
Vinyl tile			X		X	X		
Raised-rubber tile					X		X	
Polishing:								
Raised Disc Tile								X
Marble								X
Vinyl tile								X

BRUSH SELECTOR GUIDE-CYLINDRICAL

We provide brushes and pad holders that will give you the best possible performance between machine and floor. Following are descriptions of the materials and their applications.

- Soft Nylon:** Least aggressive brush available. Used on soft-finish floors where a more aggressive brush would leave scratch marks, or in applications requiring very light cleaning.
- Stiff Nylon:** Cleaning action similar to polypropylene. More durable and wear-resistant than polypropylene.
- Prolene:** Low cost, yet effective in cleaning many common floor surfaces.
- MidLite Grit 180:** Least aggressive grit brush. Used for daily cleaning of hard-finished floors.
- Dyna Grit 80:** Medium aggressive grit brush. Good all-around brush for medium to heavy buildup removal. Can also be used for general stripping operations.
- Magna Grit 46:** Most aggressive grit brush. Used primarily to clean heavy buildup on concrete floors in factories, or for heavy stripping of finish.

BR 755 BRUSHES

- 56412191 - Soft Nylon
- 56412192 - Hard Nylon
- 56412046 - Prolene
- 56412193 - MidLite Grit 180
- 56412194 - Dyna Grit 80
- 56412195 - Magna Grit 46

CYLINDRICAL BRUSH APPLICATION GUIDE (SUGGESTION ONLY)

Application	46 Grit	80 Grit	180 Grit	Polypro- pylene	Stiff Nylon	Soft Nylon
Stripping:						
Concrete	X	X				
Terrazzo	X	X				
Ceramic/Quarry tile		X				
Vinyl tile		X				
General Scrubbing:						
Concrete	X	X	X	X	X	
Terrazzo			X	X	X	X
Ceramic/Quarry tile			X	X	X	X
Marble			X		X	X
Vinyl tile			X	X	X	X
Raised-rubber tile			X			X

SQUEEGEE BLADE SELECTOR GUIDE

Gum Rubber: Provides superior wiping action on tile, terrazzo, and polished floors.

Red Gum Rubber: Provides longest life on finished or unfinished concrete floors.

Polyurethane: Oil resistance provides superior life in applications with oily floors.

SQUEEGEE BLADE APPLICATION GUIDE(SUGGESTION ONLY)

	Gum Rubber (Natural Rubber)	Red Gum Rubber (Natural Rubber)	Polyurethane/Pentathane
Performance Traits			
Tear Strength		X	X
Abrasion Resistance		X	X
Applications			
Oil Resistant Applications			X
Appearance	Tan	Red	Translucent



We supply a full range of cleaning equipment for rental or purchase.

For more information, or a cleaning solution to suit your business, please get in touch –

For a more comprehensive product range, please visit our website.



crescent
Industrial cleaning equipment

Address

Berrington House,
Berrington Road,
Leamington Spa
CV31 1NB

Contact

t: 0845 33 77 695
f: 0845 33 78 695
e: info@c-ind.co.uk

www.crescentindustrial.co.uk