Service Manual



TABLE OF CONTENTS

GENERAL INFORMATION	4
CONVENTIONS.....	4
MACHINE LIFTING.....	4
MACHINE TRANSPORTATION.....	4
OTHER REFERENCE MANUALS.....	4
SAFETY	5
SYMBOLS.....	5
GENERAL INSTRUCTIONS.....	5
TECHNICAL DATA (For BA 451, BA 451D, BA 531, BA 531D).....	8
TECHNICAL DATA (For CA 451, CA 531).....	9
TECHNICAL DATA (For BA 551, BA 551D, BA 551CD, BA 611D).....	10
TECHNICAL DATA (For CA 551).....	11
DIMENSIONS BA 451 - DIMENSIONS BA 451D.....	12
DIMENSIONS BA 531 - DIMENSIONS BA 531D.....	13
DIMENSIONS CA 451 - DIMENSIONS CA 531.....	14
DIMENSIONS BA 551 - DIMENSIONS BA 551D.....	15
DIMENSIONS BA 551CD - DIMENSIONS BA 611D.....	16
DIMENSIONS CA 551.....	17
MAINTENANCE	18
SCHEDULED MAINTENANCE TABLE (For BA 451, BA 451D, BA 531, BA 531D, BA 551, BA 551D, BA 551CD, BA 611D).....	18
SCHEDULED MAINTENANCE TABLE (For CA 451, CA 531, CA 551).....	18
MACHINE NOMENCLATURE (For BA 451, BA 451D, BA 531, BA 531D).....	19
MACHINE NOMENCLATURE (For BA 551, BA 551D, BA 551CD, BA 611D).....	22
MACHINE NOMENCLATURE (For CA 451, CA 531).....	25
MACHINE NOMENCLATURE (For CA 551).....	27
SOLUTION/CLEAN WATER SUPPLY SYSTEM	29
SOLUTION/CLEAN WATER TANK AND SUPPLY SYSTEM CLEANING (All models).....	29
SOLUTION FILTER CLEANING (For BA 451, BA 451D, BA 531, BA 531D, CA 451, CA 531, without EcoFlex™ system).....	29
SOLUTION FILTER CLEANING (For BA 551, BA 551D, BA 551CD, BA 611D, CA 551, without EcoFlex™ system).....	30
SOLENOID VALVE DISASSEMBLY/ASSEMBLY (For BA 451, BA 451D, BA 531, BA 531D, CA 451, CA 531).....	31
SOLENOID VALVE DISASSEMBLY/ASSEMBLY (For BA 551, BA 551D, BA 551CD, BA 611D, CA 551).....	32
TROUBLESHOOTING.....	33
ECOFLEX™ SYSTEM	34
CLEAN WATER FILTER CLEANING (For BA 451D, BA 531D).....	34
CLEAN WATER FILTER CLEANING (For BA 551D, BA 551CD, BA 611D).....	35
DETERGENT TANK CLEANING (For BA 451D, BA 531D, BA 551D, BA 551CD, BA 611D).....	36
ECOFLEX™ SYSTEM DRAINING (For BA 451D, BA 531D, BA 551D, BA 551CD, BA 611D).....	37
WATER PUMP DISASSEMBLY/ASSEMBLY (For BA 451D, BA 531D, BA 551D, BA 551CD, BA 611D).....	38
DETERGENT PUMP AND CHECK VALVE DISASSEMBLY/ASSEMBLY (For BA 451D, BA 531D).....	39
DETERGENT PUMP AND CHECK VALVE DISASSEMBLY/ASSEMBLY (For BA 551D, BA 551CD, BA 611D).....	41
TROUBLESHOOTING.....	43

BRUSHING SYSTEM	44
BRUSH/PAD CLEANING	44
BRUSH/PAD-HOLDER/CYLINDRICAL BRUSH DECK DISASSEMBLY/ASSEMBLY (For BA 451, BA 451D, BA 531, BA 531D)	45
BRUSH/PAD-HOLDER/CYLINDRICAL BRUSH DECK DISASSEMBLY/ASSEMBLY (For BA 551, BA 551D, BA 551CD, BA 611D)	46
BRUSH/PAD-HOLDER DECK DISASSEMBLY/ASSEMBLY (For CA 451, CA 531, CA 551)	47
BRUSH MOTOR ELECTRICAL INPUT CHECK (For BA 451, BA 451D, BA 531, BA 531D).....	49
BRUSH MOTOR ELECTRICAL INPUT CHECK (For BA 551, BA 551D)	51
BRUSH MOTOR ELECTRICAL INPUT CHECK (For BA 551CD).....	53
BRUSH MOTOR ELECTRICAL INPUT CHECK (For BA 611D)	54
BRUSH MOTOR ELECTRICAL INPUT CHECK (For CA 451, CA 531, CA 551).....	55
BRUSH MOTOR CARBON BRUSH CHECK/REPLACEMENT (For BA 451, BA 451D, BA 531, BA 531D).....	57
BRUSH MOTOR CARBON BRUSH CHECK/REPLACEMENT (For BA 551, BA 551D)	59
BRUSH MOTOR CARBON BRUSH CHECK/REPLACEMENT (For BA 551CD)	61
BRUSH MOTOR CARBON BRUSH CHECK/REPLACEMENT (For BA 611D)	62
BRUSH MOTOR DISASSEMBLY/ASSEMBLY (For BA 451, BA 451D, BA 531, BA 531D, BA 551, BA 551D)	63
BRUSH MOTOR DISASSEMBLY/ASSEMBLY (For BA 551CD).....	64
BRUSH MOTOR DISASSEMBLY/ASSEMBLY (For BA 611D).....	65
BRUSH MOTOR DISASSEMBLY/ASSEMBLY (For CA 451, CA 531, CA 551)	66
CHECK/REPLACEMENT/ADJUSTMENT OF DRIVING BELTS FROM MOTORS TO CYLINDRICAL BRUSHES (For BA 551CD).....	67
BRUSH ENABLING MICROSWITCH ADJUSTMENT/REPLACEMENT (For BA 451D, BA 531D, BA 551D, BA 551CD, BA 611D)	69
TROUBLESHOOTING	74
RECOVERY WATER SYSTEM	72
RECOVERY WATER TANK AND VACUUM GRID CLEANING, AND COVER GASKET CHECK (All models)	72
SQUEEGEE CLEANING/CHECK/REPLACEMENT AND SQUEEGEE BLADE REPLACEMENT (All models).....	73
VACUUM SYSTEM MOTOR FILTER CLEANING (All models)	75
VACUUM SYSTEM MOTOR ELECTRICAL INPUT CHECK (For BA 451, BA 451D, BA 531, BA 531D, BA 551, BA 551D, BA 551CD, BA 611D)	76
VACUUM SYSTEM MOTOR ELECTRICAL INPUT CHECK (For CA 451, CA 531, CA 551)	77
VACUUM SYSTEM MOTOR CARBON BRUSH CHECK/REPLACEMENT (All models)	79
VACUUM SYSTEM MOTOR DISASSEMBLY/ASSEMBLY (All models).....	80
SQUEEGEE SPRING CHECK/REPLACEMENT (All models, with aluminium squeegee)	82
TROUBLESHOOTING	83
DRIVE SYSTEM	84
SPEED POTENTIOMETER ADJUSTMENT/REPLACEMENT (For BA 451D, BA 531D, BA 551D, BA 551CD, BA 611D)	84
MAXIMUM SPEED POTENTIOMETER DISASSEMBLY/ASSEMBLY (For BA 451D, BA 531D, BA 551D, BA 551CD, BA 611D)	86
DRIVE SYSTEM MOTOR ELECTRICAL INPUT CHECK (For BA 451D, BA 531D, BA 551D, BA 551CD, BA 611D)	88
DRIVE SYSTEM MOTOR CARBON BRUSH CHECK AND REPLACEMENT (For BA 451D, BA 531D, BA 551D, BA 551CD, BA 611D)	90
DRIVE SYSTEM MOTOR-DIFFERENTIAL DISASSEMBLY/ASSEMBLY (For BA 451D, BA 531D, BA 551D, BA 551CD, BA 611D)	91
TROUBLESHOOTING	92
DRIVE SYSTEM ELECTRONIC BOARD DIAGNOSTIC TABLE	93

OTHER SYSTEMS	94
SCREW AND NUT TIGHTENING CHECK (All models).....	94
ELECTRICAL SYSTEM	95
MACHINE WORKING HOUR CHECK (For BA 451, BA 451D, BA 531, BA 531D, BA 551, BA 551D, BA 551CD, BA 611D, equipped with optional hour counter).....	95
MACHINE WORKING HOUR CHECK (For CA 451, CA 531, CA 551, equipped with optional hour counter)	95
POWER SUPPLY CABLE CHECK (For CA 451, CA 531, CA 551)	95
BATTERY CHARGE AND MAINTENANCE (All models)	95
BATTERY DISASSEMBLY/ASSEMBLY (For BA 451, BA 451D; BA 531, BA 531D, BA 551, BA 551D, BA 551CD, BA 611D).....	96
BATTERY TYPE SETTING (WET OR GEL) (For BA 451, BA 531, BA 551).....	97
BATTERY TYPE SETTING (WET OR GEL) (For BA 451D, BA 531D, BA 551D, BA 551CD, BA 611D)	98
FUSE CHECK/REPLACEMENT (For BA 451, BA 451D, BA 531, BA 531D, BA 551, BA 551D, BA 551CD, BA 611D)	99
FUSE CHECK/REPLACEMENT (For CA 431, CA 531, CA 551)	100
BRUSH MOTOR ELECTROMAGNETIC SWITCH DISASSEMBLY/ASSEMBLY (For BA 451, BA 451D, BA 531, BA 531D, BA 551, BA 551D, BA 551CD, BA 611D)	101
DRIVE SYSTEM ELECTRONIC BOARD DISASSEMBLY/ASSEMBLY (For BA 451D, BA 531D, BA 551D, BA 551CD, BA 611D)	103
FUNCTION ELECTRONIC BOARD DISASSEMBLY/ASSEMBLY (For BA 451, BA 451D, BA 531, BA 531D, BA 551, BA 551D, BA 551CD, BA 611D)	105
WATER FLOW CONTROL ELECTRONIC BOARD DISASSEMBLY/ASSEMBLY (For CA 451, CA 531, CA 551)	106
TROUBLESHOOTING	107
COMPONENT LAYOUT (For BA 451, BA 531, BA 551)	108
WIRING DIAGRAM (For BA 451, BA 531, BA 551).....	109
COMPONENT LAYOUT (For BA 451D, BA 531D, BA 551D, BA 551CD, BA 611D).....	110
WIRING DIAGRAM (For BA 451D, BA 531D, BA 551D, BA 551CD, BA 611D).....	112
COMPONENT LAYOUT (For CA 451, CA 531, CA 551).....	113
WIRING DIAGRAM (For CA 451, CA 531, CA 551)	114
EB1 ELECTRONIC BOARD CONNECTOR PINS (for BA 451, BA 451D, BA 531, BA 531D, BA 551, BA 551D, BA 551CD, BA 611D).....	115

GENERAL INFORMATION

GENERAL INFORMATION

CONVENTIONS

Forward, backward, front, rear, left or right are intended with reference to the operator's position, that is to say in driving position with the hands on the handlebar.

MACHINE LIFTING

**WARNING!**

Do not work under the lifted machine without supporting it with safety stands.

MACHINE TRANSPORTATION

**WARNING!**

Before transporting the machine, make sure that:

- *All covers are closed.*
- *The ignition key is removed.*
- *The machine is securely fastened to the means of transport.*

OTHER REFERENCE MANUALS

The following manuals are available at Nilfisk Literature Service Department:

- **BA 451 - BA 451D - BA 531 - BA 531D**: User Manual - Form Number 909 6748 000
- **BA 451 - BA 451D - BA 531 - BA 531D**: Spare Parts List - Form Number 909 6749 000
- **BA 551, BA 551D, BA 551CD, BA 611D**: User Manual - Form Number 909 6752 000
- **BA 551, BA 551D, BA 551CD, BA 611D**: Spare Parts List - Form Number 909 6753 000
- **CA 451 - CA 531**: User Manual - Form Number 909 6750 000
- **CA 451 - CA 531**: Spare Parts List - Form Number 909 6751 000
- **CA 551**: User Manual - Form Number 909 6754 000
- **CA 551**: Spare Parts List - Form Number 909 6755 000
- Installation instructions counter hour kit - Form Number 9096952000
- Installation instructions for extra pressure kit - Form Number 909 6759 000
- Installation instructions for splash guard kit - Form Number 909 6745 000
- Installation instructions for battery charger kit - Form Number 909 6746 000
- Installation instructions for EcoFlex™ kit Delta 6 - Form Number 9096936000
- Installation instructions for EcoFlex™ kit Delta 7- Form Number 909 6747 000

GENERAL INFORMATION

SAFETY

The following symbols indicate potentially dangerous situations. Always read this information carefully and take all necessary precautions to safeguard people and property.

SYMBOLS

**DANGER!**

It indicates a dangerous situation with risk of death for the operator.

**WARNING!**

It indicates a potential risk of injury for people or damage to objects.

**CAUTION!**

It indicates a caution related to important or useful functions.

Pay careful attention to the paragraphs marked by this symbol.

**NOTE**

It indicates a remark related to important or useful functions.

**CONSULTATION**

It indicates the necessity to refer to the User Manual before performing any procedure.

GENERAL INSTRUCTIONS

Specific warnings and cautions to inform about potential damages to people and machine are shown below.

**DANGER!**

- *This machine must be used by properly trained operators only. Children or disabled people cannot use this machine.*
- *Do not wear jewels when working near electrical components.*
- *Do not work under the lifted machine without supporting it with safety stands.*
- *Do not operate the machine near toxic, dangerous, flammable and/or explosive powders, liquids or vapours: This machine is not suitable for collecting dangerous powders.*

**DANGER! (For BA 451, BA 451D, BA 531, BA 531D, BA 551, BA 551D, BA 551CD, BA 611D)**

- *Before performing any cleaning, maintenance, repair or replacement procedure disconnect the battery connector and remove the ignition key.*
- *Keep the battery far from sparks, flames and incandescent material. During the normal operation explosive gases are released.*
- *Battery charging produces highly explosive hydrogen gas. Keep the tanks lifted during battery charging and perform this operation in well-ventilated areas and away from naked flames.*

**DANGER! (For CA 451, CA 531, CA 551)**

- *Always disconnect the power supply cable when the machine is not in use, before performing maintenance procedures, before replacing the brush/pad-holder and before opening any access panel.*

GENERAL INFORMATION



WARNING!

- *To avoid any unauthorized use of the machine, remove the ignition key.*
- *Do not leave the machine unattended without being sure that it cannot move independently.*
- *Always protect the machine against the sun, rain and bad weather, both under operation and inactivity condition. Store the machine indoors, in a dry place: This machine must be used in dry conditions, it must not be used or kept outdoors in wet conditions.*
- *Before using the machine, close all doors and/or covers.*
- *Do not allow to be used as a toy. Close attention is necessary when used near children.*
- *Use only as shown in this Manual. Only Nilfisk recommended accessories must be used.*
- *Take all necessary precautions to prevent hair, jewels and loose clothes from being caught by the machine moving parts.*
- *Do not use the machine on slopes with a gradient exceeding the specifications.*
- *Do not use the machine in particularly dusty areas.*
- *While using this machine, take care not to cause damage to people or objects.*
- *Do not bump into shelves or scaffoldings, especially where there is a risk of falling objects.*
- *Do not put any can containing fluids on the machine.*
- *The machine working temperature must be between +32°F and +104°F (0°C and +40°C).*
- *The machine storage temperature must be between +32°F and +104°F (0°C and +40°C).*
- *The humidity must be between 30% and 95%.*
- *When using floor cleaning detergents, follow the instructions on the labels of the detergent bottles.*
- *To handle floor cleaning detergents, wear suitable gloves and protections.*
- *Do not use the machine as a means of transport.*
- *Do not allow the brushes to operate while the machine is stationary to avoid damaging the floor.*
- *In case of fire, use a powder fire extinguisher, not a water one.*
- *Do not tamper with the machine safety guards and follow the ordinary maintenance instructions scrupulously.*
- *Do not allow any object to enter into the openings. Do not use the machine if the openings are clogged. Always keep the openings free from dust, hairs and any other foreign material which could reduce the air flow.*
- *Do not remove or modify the plates affixed to the machine.*
- *This machine cannot be used on roads or public streets.*
- *Pay attention during machine transportation when temperature is below freezing point. The water in the recovery tank or in the hoses could freeze and seriously damage the machine.*
- *Use brushes and pads supplied with the machine and those specified in the User Manual. Using other brushes or pads could reduce safety.*
- *In case of machine malfunctions, ensure that these are not due to lack of maintenance. Otherwise, request assistance from the authorised personnel or from an authorised Service Center.*
- *If parts must be replaced, require ORIGINAL spare parts from a Dealer or Authorised Retailer.*
- *To ensure machine proper and safe operation, the scheduled maintenance shown in the relevant chapter of this Manual, must be performed by the authorised personnel or by an authorised Service Center.*
- *Carefully read all the instructions before performing any maintenance/repair procedure.*
- *Do not wash the machine with direct or pressurised water jets, or with corrosive substances.*
- *The machine must be disposed of properly, because of the presence of toxic-harmful materials (batteries, etc.), which are subject to standards that require disposal in special centres (see the User Manual).*

GENERAL INFORMATION

WARNING! (For BA 451, BA 451D, BA 531, BA 531D, BA 551, BA 551D, BA 551CD, BA 611D)

- *Do not pull or carry the machine by the battery charger cable and never use the battery charger cable as a handle. Do not close a door on the battery charger cable, or pull the battery charger cable around sharp edges or corners. Do not run the machine on the battery charger cable.*
- *Keep the battery charger cable away from heated surfaces.*
- *Do not charge the batteries if the battery charger cable or the plug are damaged. If the machine is not working as it should, has been damaged, left outdoors or dropped into water, return it to the Service Centre.*
- *Before using the battery charger, ensure that frequency and voltage values, indicated on the machine serial number plate, match the electrical mains voltage.*
- *Do not smoke while charging the batteries.*
- *To reduce the risk of fire, electric shock, or injury, do not leave the machine unattended when it is plugged in. Before performing any maintenance procedure, disconnect the battery charger cable from the electrical mains.*



WARNING! (For CA 451, CA 531, CA 551)

- *The machine power supply cable is grounded and the relevant plug is grounded too. In case of machine malfunction or breakdown, grounding connection reduces the risk of electric shock.*
- *The power supply cable plug must be connected to an appropriate outlet, which is grounded according to law in force. Improper connection can cause electric shock.*
- *Do not tamper with the power supply cable plug. If the power supply cable plug cannot be connected to the outlet, have new grounded outlet installed by a qualified technician, according to the law in force.*
- *Before connecting the power supply cable to the electrical mains, check that frequency and voltage, shown on the machine serial number plate, match the electrical mains voltage.*
- *Do not unplug the machine by pulling the supply cable. To unplug, grasp the plug, not the cable.*
- *Do not handle the plug or the machine with wet hands.*
- *Turn off all controls before unplugging.*
- *Regularly check the power supply cable for damages, cuts, cracks and wear. If necessary, replace it.*
- *If the power supply cable is damaged, contact the Nilfisk Service Center for replacement.*
- *Do not pull or carry the machine by the power supply cable and never use the power supply cable as a handle. Do not close a door on the power supply cable, or pull the power supply cable around sharp edges or corners. Do not run the machine on the power supply cable.*
- *The brushes must not come into contact with the power supply cable.*
- *Keep the power supply cable away from heated surfaces.*
- *To reduce the risk of fire, electric shock, or injury, do not leave the machine unattended when it is plugged in. Disconnect the machine from the electrical mains when not in use and before performing maintenance procedures.*
- *If the machine:*
 - *does not work properly*
 - *is damaged*
 - *has water or foam leaks*
 - *has been left outdoors exposed to bad weather conditions*
 - *is wet or has been dropped into water**turn it off immediately and contact the Nilfisk Service Center or a qualified technician.*

GENERAL INFORMATION

TECHNICAL DATA (For BA 451 - BA 451D - BA 531 - BA 531D)

Model	BA 451 (1 brush/pad- holder, without drive system)	BA 451D (1 brush/pad- holder, with drive system)	BA 531 (1 brush/pad- holder, without drive system)	BA 531D (1 brush/pad- holder, with drive system)
Machine height	41.6 in (1,058.5 mm)			
Solution/clean water tank capacity	10.5 gal (40 litres)			
Recovery water tank capacity	10.5 gal (40 litres)			
Min/max solution flow without EcoFlex™ system	0 ÷ 0,42 gal/min (0 ÷ 1,6 lt/min)			
Min/max solution flow with EcoFlex™ system	-	0 ÷ 0,4 gal/min (0 ÷ 1.5 lt/min)	-	0 ÷ 0,4 gal/min (0 ÷ 1.5 lt/min)
EcoFlex™ system tank capacity	-	1,3 gal (5 litri)	-	1,3 gal (5 litri)
EcoFlex™ system setting	-	0,25% ÷ 3%	-	0,25% ÷ 3%
Solution/clean water autonomy	0.29 gal/min (1,1 lt/min) ~ 36 min Media/Average			
Front wheel diameter	7.8 in (200 mm)			
Front wheel specific pressure on the ground (*)	174 psi (1,2 N/mm ²)			
Rear wheel diameter	3.9 in (100 mm)			
Rear wheel specific pressure on the ground (*)	435 psi (3 N/mm ²)			
Minimum turning radius	23,6 in (600 mm)		25,6 in (650 mm)	
Vacuum system motor power	0,44 hp (330 W)			
Drive system motor power	-	0,27 hp (200 W)	-	0,27 hp (200 W)
Drive speed (variable)	-	da 0 a 2,8 MPH (da 0 a 6 km/h)	-	da 0 a 2,8 MPH (da 0 a 6 km/h)
Working gradeability	2% - 1°			
Sound pressure level (at the operator's position) (ISO 11201, ISO 4871) (LpA)	66 dB(A) ± 3dB(A)			
Sound pressure level (to the machine) (ISO 3744, ISO 4871) (LwA)	84 dB(A)			
Vibration level at the operator's arms (ISO 5349-1)	< 98,4 in/s ² (< 2.5 m/s ²)			
Standard batteries	DRY: (2 x 12 V) 24 V 110 Ah / 5 h			
Standard batteries autonomy	~ 3,2h	~ 2,6h	~ 3,2h	~ 2,6h
Battery compartment size (width x length x height)	13,8 x 13,8 x 11,8 in (350 x 350 x 300 mm)			
Total consumption in work condition	29 A			
Vacuum system circuit capacity	1,034 Mpa (1055 mm H ₂ O)			
Cleaning width	18,0 in (450 mm)		21,0 in (530 mm)	
Squeegee width	30,0 in (760 mm)			
Machine maximum length	46,8 in (1190 mm)		48,3 in (1228 mm)	
Machine width without squeegee	20,1 in (512 mm)		21,2 in (540,8 mm)	
Brush diameter	18,0 in (450 mm)		21,0 in (530 mm)	
Deck right/left offset	1,5/- in (37,1/- mm)		3/- in (75,9/- mm)	
Brush distance from the ground (when lifted)	2,4 in (60,1 mm)			
Weight without batteries and with empty tanks	194,0 lb (88 kg)			
Maximum weight with batteries and full tanks	479,6 lb (218 kg)			
Brush motor power	0,65 hp (480 W)			
Brush speed	153 rpm			
Brush/pad-holder pressure with extra-pressure function turned off	42,0 lb (19,0 kg)		45,1 lb (20,5 kg)	
Brush/pad-holder pressure with extra-pressure function turned on	57,9 lb (26,3 kg)		61,6 lb (27,8 kg)	

(*) Machine test have been performed under the following conditions:

- Battery maximum size
- Brush and squeegee maximum size
- Full clean water tank
- Optional equipment installed
- Wheel weight checked
- Each wheel print checked on cement
- Result expressed as maximum value for both front and rear wheels

GENERAL INFORMATION**TECHNICAL DATA (Per BA 551, BA 551D, BA 551CD, BA 611D)**

General technical data				
Model	BA 551 (1 brush/pad- holder, without drive system)	BA 551D (1 brush/pad- holder, with drive system)	BA 551CD (2 cylindrical brushes, with drive system)	BA 611D (2 brushes/pad- holders, with drive system)
Machine height	42,8 in (1.088 mm)			
Solution/clean water tank capacity	15,3 gal (58 litri)			
Recovery water tank capacity	16,0 gal (60 litri)			
Min/max solution flow without EcoFlex™ system	0 ÷ 0,42 gal/min (0 ÷ 1,6 lt/min)			
Min/max solution flow with EcoFlex™ system	-	0 ÷ 0,4 gal/min (0 ÷ 1.5 lt/min)		
EcoFlex™ system tank capacity	-	1,3 gal (5 litri)		
EcoFlex™ system setting	-	0,25% ÷ 3%		
Solution/clean water autonomy	0.29 gal/min (1,1 lt/min) ~ 52 min Media/Average			
Front wheel diameter	9,8 in (250 mm)			
Front wheel specific pressure on the ground	174 psi (1,2 N/mm ²)			
Rear wheel diameter	3,9 in (100 mm)			
Rear wheel specific pressure on the ground (*)	667 psi (4,6 N/mm ²)			
Minimum turning radius	27.5 in (700 mm)			
Vacuum system motor power	0,44 hp (330 W)			
Drive system motor power	-	0,27 hp (200 W)		
Drive speed (variable)	-	da 0 a 3,5 MPH (da 0 a 5,6 km/h)		
Working gradeability	2% - 1°			
Sound pressure level (at the operator's position) (ISO 11201, ISO 4871) (LpA)	66 dB(A) ± 3dB(A)			
Sound pressure level (to the machine) (ISO 3744, ISO 4871) (LwA)	84 dB(A)			
Vibration level at the operator's arms (ISO 5349-1)	< 98,4 in/s ² (< 2.5 m/s ²)			
Standard batteries	GEL: (2 x 12 V) 24 V 110 Ah / 5 h			
Standard batteries autonomy	~ 3,2h	~ 2,6h		
Battery compartment size (width x length x height)	13,8 x 13,8 x 11,8 in (350 x 350 x 300 mm)			
Total consumption in work condition	29 A			
Vacuum system circuit capacity	1,034 Mpa (1.055 mm H ₂ O)			

(*) Machine test have been performed under the following conditions:

- Battery maximum size
- Brush and squeegee maximum size
- Full clean water tank
- Optional equipment installed
- Wheel weight checked
- Each wheel print checked on cement
- Result expressed as maximum value for both front and rear wheels

GENERAL INFORMATION**TECHNICAL DATA (Per BA 551, BA 551D, BA 551CD, BA 611D) (continues)**

Technical data for machines with brush/pad-holder deck			
Model	BA 551 (1 brush/pad-holder, without drive system)	BA 551D (1 brush/pad-holder, with drive system)	BA 611D (2 brushes/pad-holders, with drive system)
Cleaning width	21,0 in (530 mm)	21,0 in 530 mm ()	24,0 in (610 mm)
Squeegee width	30,0 in (760 mm)		32,0 in (810 mm)
Machine maximum length	52,1 in (1.323 mm)		51,6 in (1.311 mm)
Machine width without squeegee	21,3 in (541 mm)		25,4 in (646 mm)
Brush diameter	21,0 in (530 mm)		12,0 in (305 mm)
Deck right/left offset	3/- in (77/- mm)		3,4/3,1 in (87/80 mm)
Brush distance from the ground (when lifted)	2,3 in (59,5 mm)		2,7 in (69,5 mm)
Weight without batteries and with empty tanks	194,0 lb (88 kg)	225,0 lb 102 kg ()	
Maximum weight with batteries and full tanks	520,3 lb (236 kg)	551,1 lb 250 kg ()	
Brush motor power	0,64 hp (480 W)		0,47 hp (350 W)
Brush speed	153 rpm		230 rpm
Brush/pad-holder pressure with extra-pressure function turned off	45,2 lb (20,5 kg)		
Brush/pad-holder pressure with extra-pressure function turned on	61,3 lb (27,8 kg)		

Technical data for machines with cylindrical brush deck	
Model	BA 551CD (2 cylindrical brushes, with drive system)
Cleaning width	20,0 in (510 mm)
Squeegee width	30,0 in (760 mm)
Machine maximum length	49,3 in (1253 mm)
Machine width without squeegee	22,7 in (575,5 mm)
Cylindrical brush size (diameter x length)	4,3 x 20,0 in (110 x 485 mm)
Deck right/left offset	3,7/0,2 in (94/4,5 mm)
Brush distance from the ground (when lifted)	1,5 in (39,5 mm)
Weight without batteries and with empty tanks	247,0 lb (112 kg)
Maximum weight with batteries and full tanks	573,2 lb (260 kg)
Brush motor power	0,54 hp (400 W)
Cylindrical brush rotation speed	570 rpm
Cylindrical brush pressure	58,4 lb (26,5 kg)

GENERAL INFORMATION

TECHNICAL DATA (Per CA 451, CA 531, CA 551)

Model	CA 451 (1 brush/pad-holder, without drive system)	CA 531 (1 brush/pad-holder, without drive system)	CA 551 (1 brush/pad-holder, without drive system)
Power supply	230 V, 50-60 Hz		
Machine height	41.6 in (1,058.5 mm)		42.8 in (1.088 mm)
Solution tank capacity	10.5 gal (40 litres)		15.3 gal (58 litri)
Recovery water tank capacity	10.5 gal (40 litres)		16.0 gal (60 litri)
Min/max solution flow	0 ÷ 0,42 gal/min (0 ÷ 1,6 lt/min)		
Solution/clean water autonomy (0.29 gal/min - Media/Average)	~ 36 min		~ 52 min
Front wheel diameter	7,8 in (200 mm)		9,8 in (250 mm)
Front wheel specific pressure on the ground (*)	87 psi (0,6 N/mm ²)		145 psi (1,0 N/mm ²)
Rear wheel diameter	3,9 in (100 mm)		
Rear wheel specific pressure on the ground (*)	464 psi (3,2 N/mm ²)		623 psi (4,3 N/mm ²)
Minimum turning radius	23,6 in (600 mm)	25,6 in (650 mm)	700 mm
Vacuum system motor power	0,74 hp (550 W), 50-60 Hz		
Working gradeability	2% - 1°		
Sound pressure level (at the operator's position) (ISO 11201, ISO 4871) (LpA)	68 dB(A) ± 3dB(A)		
Sound pressure level (to the machine) (ISO 3744, ISO 4871) (LwA)	84 dB(A)		
Vibration level at the operator's arms (ISO 5349-1)	< 98,4 in/s ² (< 2.5 m/s ²)		
Total consumption in work condition	6 A (50Hz) - 7 A (60Hz)		
Vacuum system circuit capacity	1,29 Mpa (1.316 mm H ₂ O)		
Cleaning width	18,0 in (450 mm)	21,0 in (530 mm)	
Squeegee width	30,0 in (760 mm)		
Machine maximum length	45,1 in (1.147 mm)	46,6 in (1.185 mm)	51,4 in (1.306 mm)
Machine width without squeegee	20,1 in (512 mm)	21,3 in (541 mm)	
Brush diameter	18,0 in (450 mm)	21,0 in (530 mm)	
Deck right/left offset	1,5/- in (37,1/- mm)	3/- in (77/- mm)	
Brush distance from the ground (when lifted)	2,3 in (59,5 mm)		
Weight with empty tanks	288,8 lb (131 kg)		
Weight with full tanks	376,2 lb (171 kg)		416,7 lb (189 kg)
Brush motor power	1,48 hp (1.100 W), 50-60 Hz		
Brush speed	150 rpm		
Brush pressure	62,2 lb (28,3 kg)	65,2 lb (29,6 kg)	66,1 lb (30 kg)

(*) Machine test have been performed under the following conditions:

- Battery maximum size
- Brush and squeegee maximum size
- Full clean water tank
- Optional equipment installed
- Wheel weight checked
- Each wheel print checked on cement
- Result expressed as maximum value for both front and rear wheels

GENERAL INFORMATION

DIMENSIONS BA 451

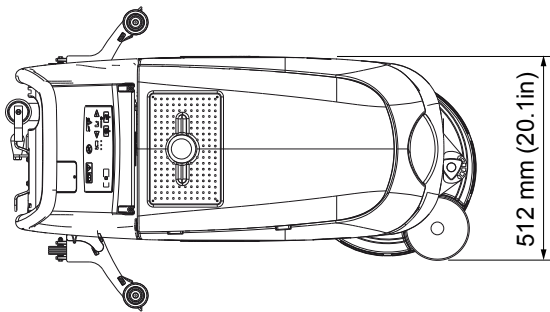
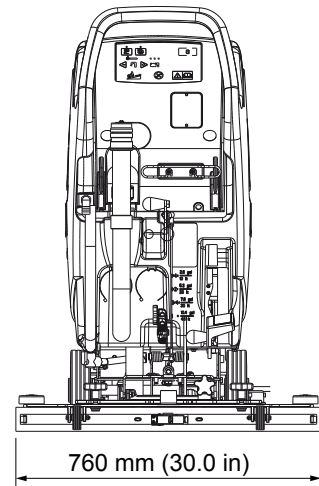
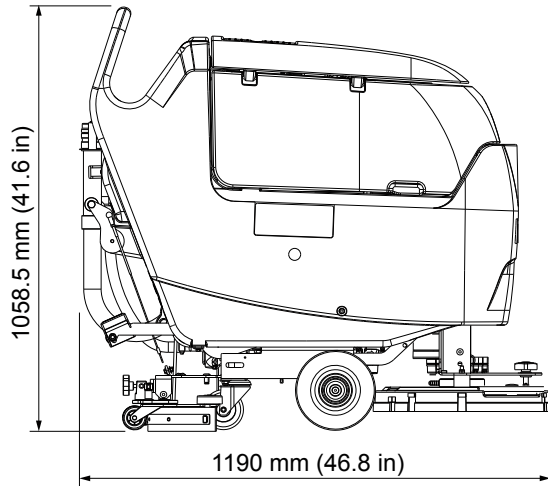

DIMENSIONS BA 451D

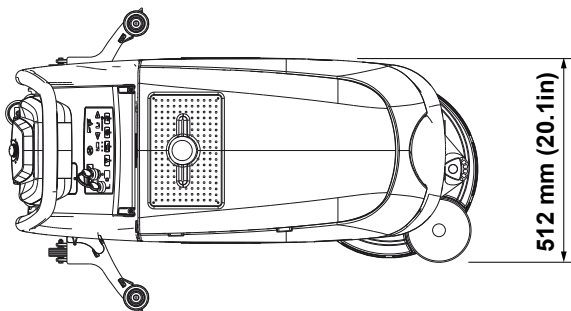
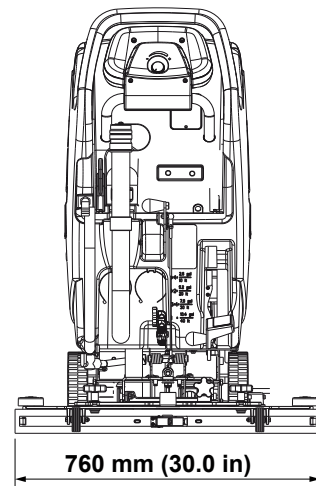
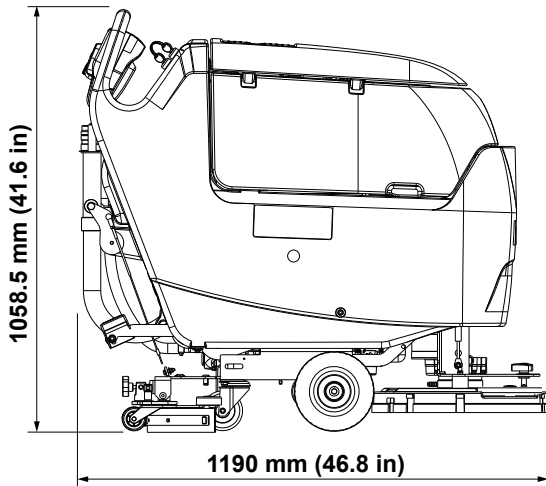

GENERAL INFORMATION

DIMENSIONS BA 531

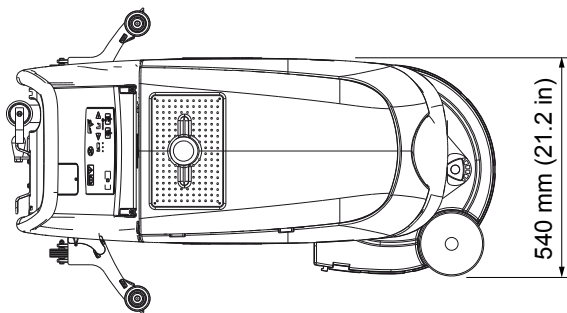
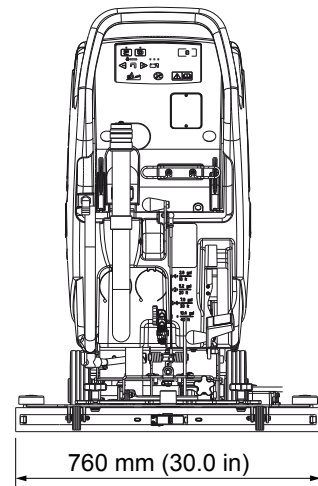
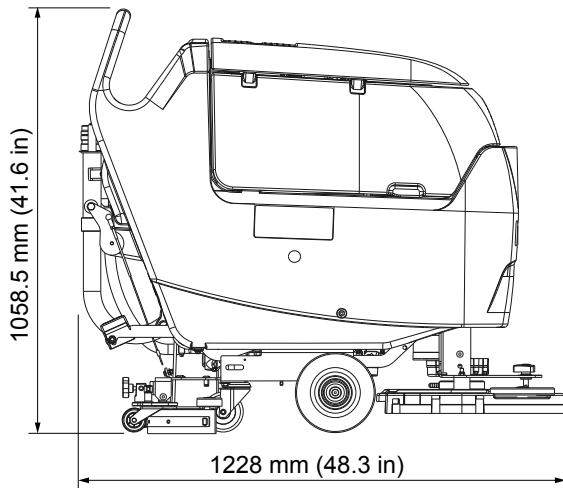

DIMENSIONS BA 531D

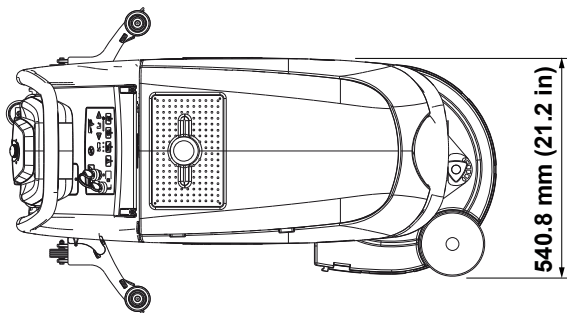
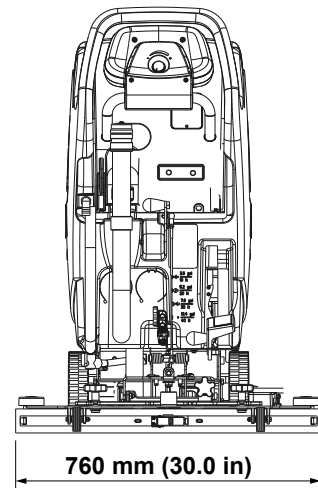
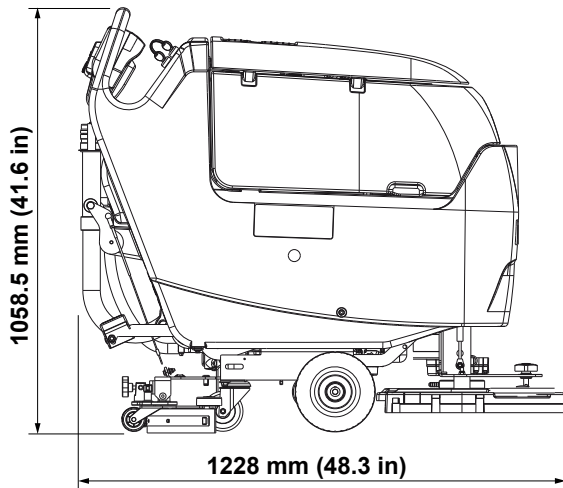

GENERAL INFORMATION

DIMENSIONS CA 451

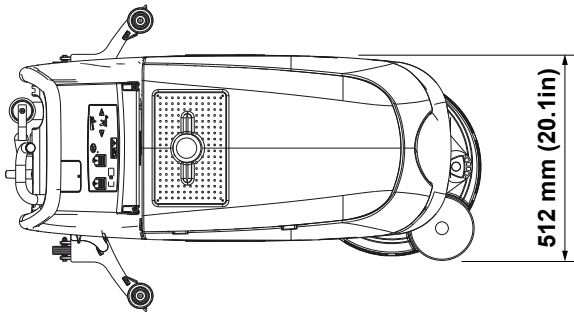
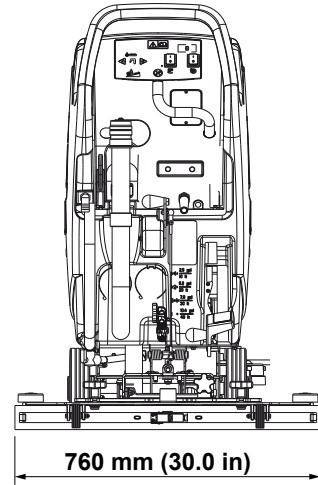
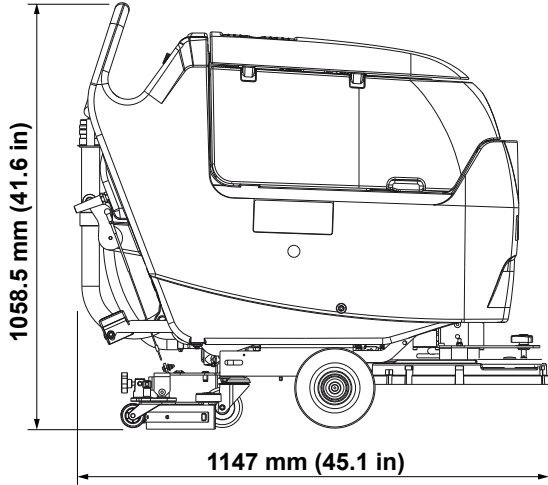

P100200

DIMENSIONS CA 531

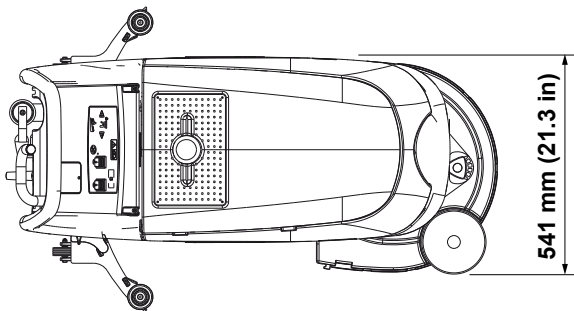
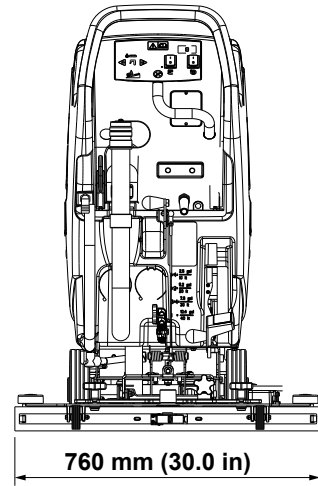
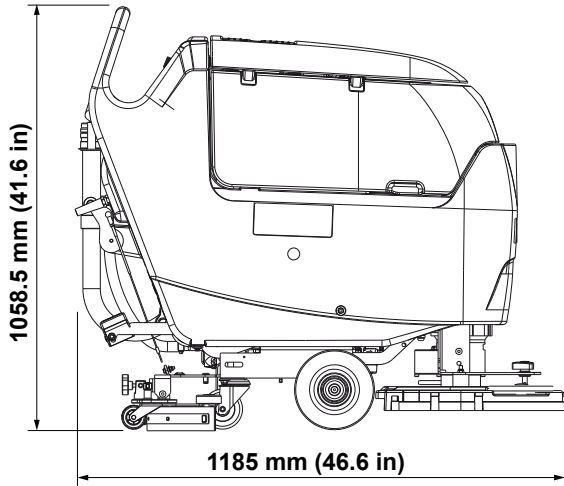

P100201

GENERAL INFORMATION

DIMENSIONS BA 551

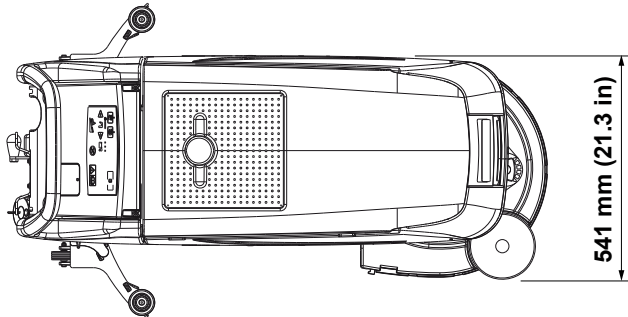
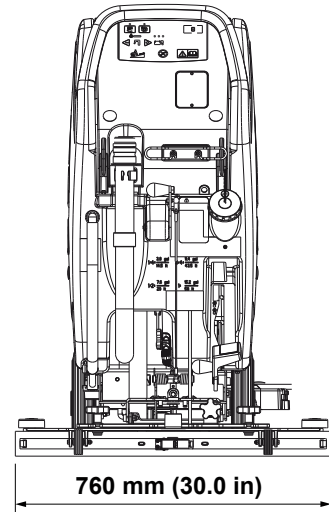
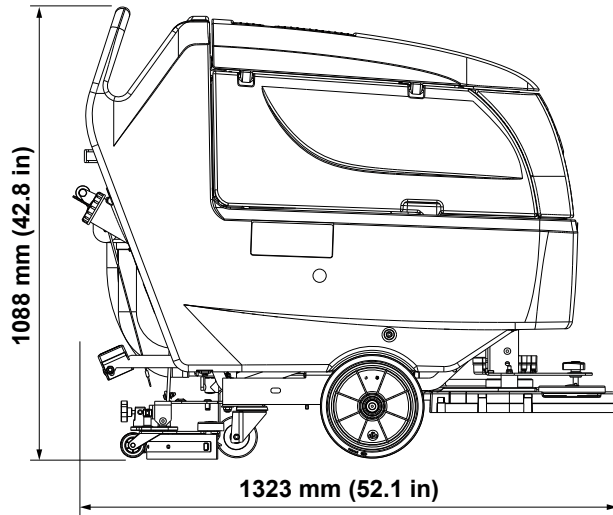

P100202

DIMENSIONS BA 551D

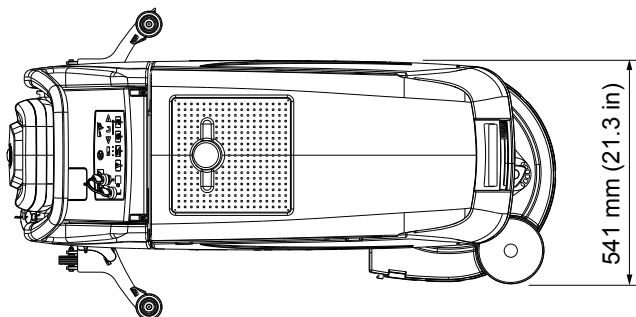
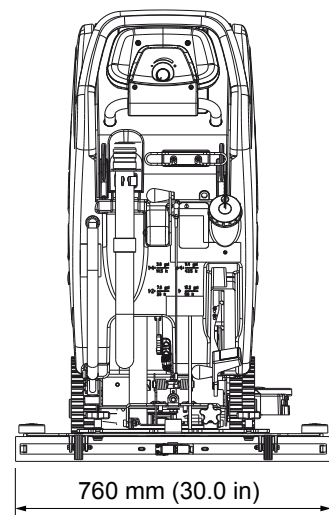
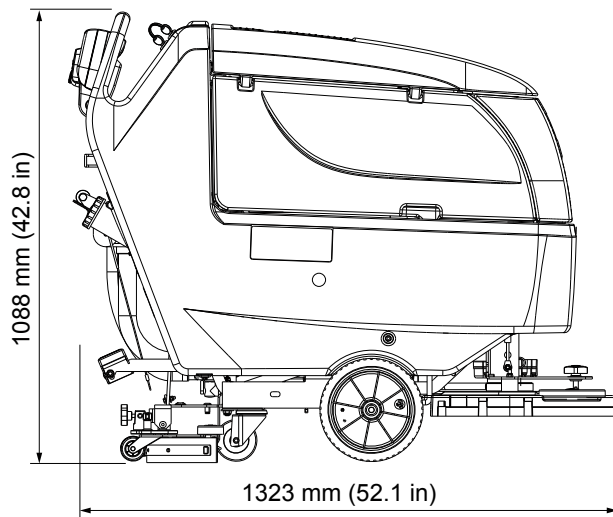

P100202

GENERAL INFORMATION

DIMENSIONS BA 551CD

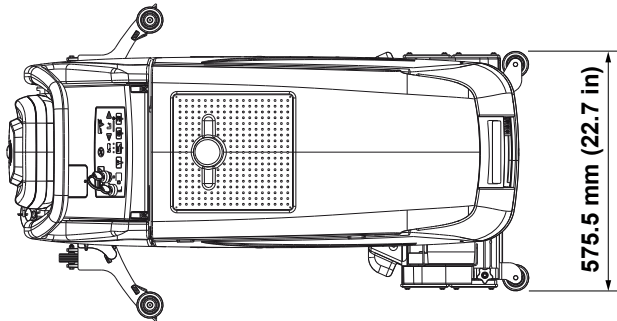
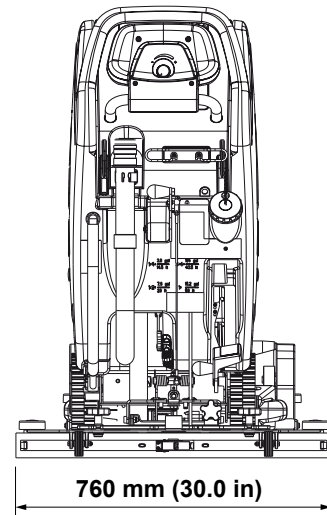
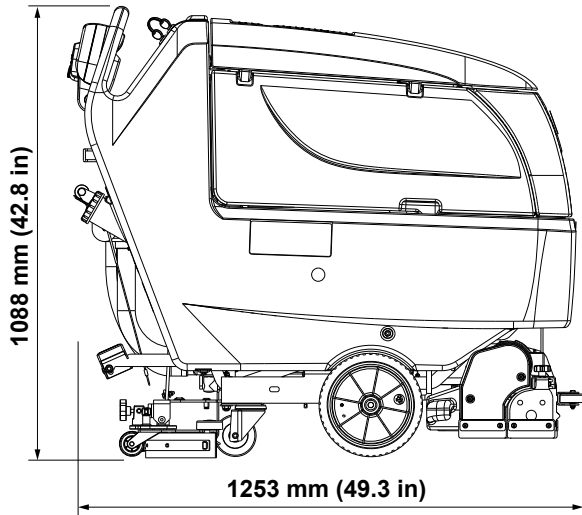

P100203

DIMENSIONS BA 611D

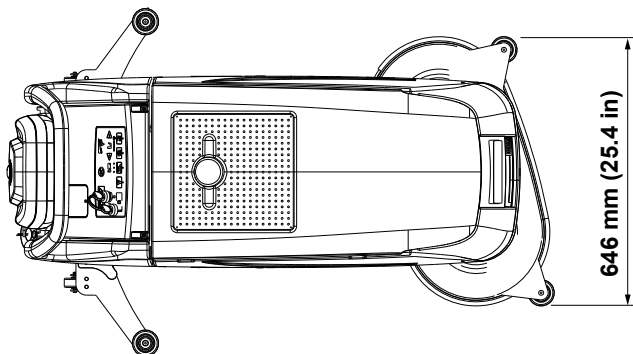
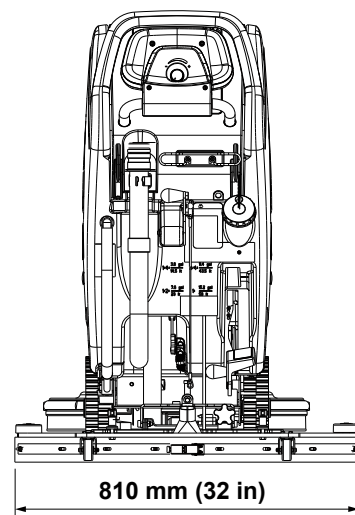
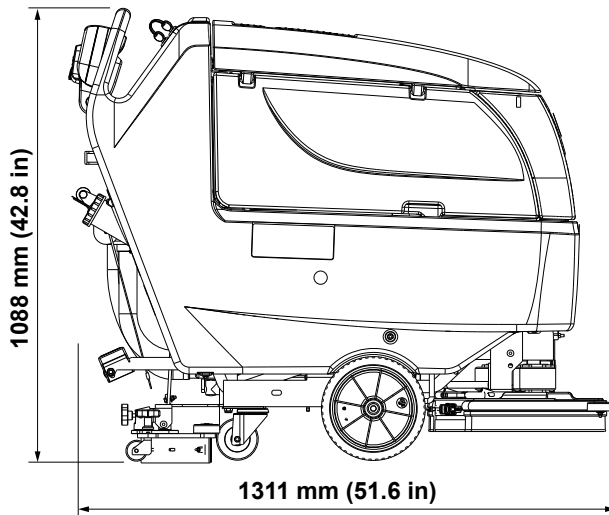

P100204

GENERAL INFORMATION

DIMENSIONS CA 551

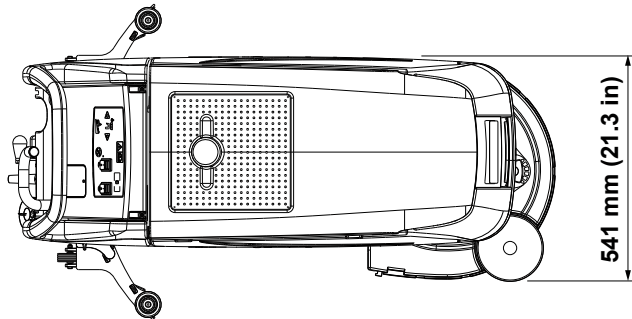
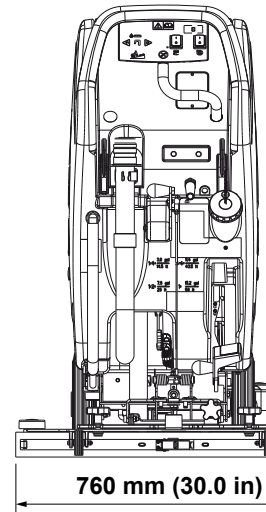
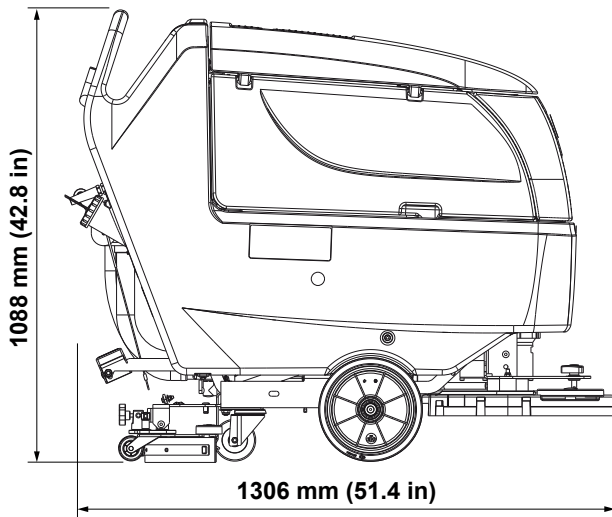

P100205

GENERAL INFORMATION

MAINTENANCE

The lifespan of the machine and its maximum operating safety are ensured by correct and regular maintenance.

WARNING!

Read carefully the instructions in the Safety chapter before performing any maintenance procedure.

The following tables provides the scheduled maintenance. The intervals shown may vary according to particular working conditions, which are to be defined by the person in charge of the maintenance.

For instructions on maintenance procedures, see the following paragraphs.

SCHEDULED MAINTENANCE TABLE (For BA 451, BA 451D, BA 531, BA 531D, BA 551, BA 551D, BA 551CD, BA 611D)

Procedure	Daily, after machine use	Weekly	Every six months	Yearly
Battery charging				
Squeegee cleaning				
Brush/pad cleaning				
Tank and vacuum grid with float cleaning, and cover gasket check				
Squeegee blade check and replacement				
EcoFlex™ system cleaning and draining (optional)				
Solution/clean water filter cleaning				
Battery (WET) fluid level check				
Vacuum system motor filter cleaning				
Screw and nut tightening check			(1)	
Brush/pad-holder motor carbon brush check or replacement				
Vacuum system motor carbon brush check or replacement				
Drive system motor carbon brush check or replacement (For BA 451D - BA 531D – BA 551D – BA 551CD - BA 611D)				

(1): And after the first 8 working hours.

SCHEDULED MAINTENANCE TABLE (For CA 451, CA 531, CA 551)

Procedure	Daily, after machine use	Weekly	Every six months	Yearly
Power supply cable check				
Squeegee cleaning				
Brush/pad cleaning				
Tank and vacuum grid with float cleaning, and cover gasket check				
Squeegee blade check and replacement				
Solution filter cleaning				
Vacuum system motor filter cleaning				
Screw and nut tightening check			(1)	
Brush/pad-holder motor carbon brush check or replacement				
Vacuum system motor carbon brush check or replacement				

(1): And after the first 8 working hours.

GENERAL INFORMATION

MACHINE NOMENCLATURE (For BA 451, BA 451D, BA 531, BA 531D)

Throughout this Manual you will find numbers in brackets – for example: (2). These numbers refer to the components indicated in these two nomenclature pages. Refer to these pages whenever you need to identify a component mentioned in the text.

- | | |
|--|--|
| 1. Control panel | 51. Clean water filter (**) |
| 2. Handlebar | 52. Batteries |
| 3. Drive paddle (*) | 53. Battery caps |
| 4. Speed adjuster (*) | 54. Solution filter |
| 5. Battery charger data inspection window (optional) | 55. Solution/clean water tap |
| 6. Battery charger cable (optional) | 56. Solenoid valve |
| 7. Battery charger cable holder (optional) | 57. Reference table for detergent proportioning (**) |
| 9. Water removable filler hose (optional) | 58. Battery connection diagram |
| 10. Squeegee lifting/lowering lever | 71. Brush/pad-holder and vacuum system switch |
| 11. Deck lifting/lowering pedal | 72. Brush/pad-holder and vacuum system switch warning led |
| 11a. Pedal position when deck is lifted | 73. Vacuum system switch |
| 11b. Pedal position when deck is lowered | 74. Vacuum system switch warning led |
| 11c. Pedal position when the extra pressure function is on (if applicable) | 75. Brush/pad-holder release switch |
| 12. Battery connector (red). This connector also works as EMERGENCY switch, to stop immediately all functions. | 76. Brush/pad-holder release switch warning led |
| 13. Rear steering wheels | 77. Detergent flow control switch (**) |
| 14. Front wheels on fixed axle | 78. Detergent flow control switch warning led |
| 15. Squeegee vacuum hose | 79. Hour counter (**) |
| 16. Recovery water drain hose | 80. Ignition key (0 - I) (*) |
| 17. Solution/clean water drain and level check hose | 81. Battery charge indicator |
| 18. Brush/pad-holder deck | 81a. Charged battery warning led (green) |
| 19. Brush/pad-holder with pad | 81b. Semi-discharged battery warning led (yellow) |
| 20. Solution/clean water tank | 81c. Discharged battery warning led (red) |
| 21. Recovery water tank | 82. Washing water flow control switches |
| 22. Recovery water tank cover | 82a. Flow increase switch |
| 23. Can holder | 82b. Flow decrease switch |
| 24. Document retainer (optional) | 82c. Washing water flow indicator |
| 25. Squeegee | 83. EcoFlex™ system switch (**) |
| 26. Squeegee mounting handwheels | 84. EcoFlex™ system warning led (**): |
| 27. Squeegee balance adjusting handwheel | • Led ON - EcoFlex™ system enabled |
| 28. Machine straight forward movement adjusting handwheel | • Led FLASHES - temporary override state |
| 29. Machine forward speed adjustment handwheel | 85. Detergent flow level display (**) |
| 30a. Recovery water tank cover (opened to be cleaned) | 90. Electronic battery charger |
| 30b. Recovery water tank cover (completely opened) | 91. Lead (WET) or gel (GEL) battery selector |
| 31. Tank cover gasket | 92. Green warning led (ON: the battery charger is on and batteries are charged) |
| 32. Cover movable retaining plate | 93. Yellow warning led (ON: the battery charger is on and batteries are semi-discharged) |
| 33. Cover fixed retaining plate | 94. Red warning led (ON: the battery charger is on and it is charging the batteries) |
| 34. Serial number plate/technical data/conformity certification | |
| 35. Plug for squeegee vacuum hose cleaning | |
| 36. Vacuum grid with automatic shut-off float | (*) Only for BA 451D, BA 531D |
| 37. Solution filler neck | (**) Only for machines equipped with EcoFlex™ system (optional) |
| 38. Foam filter | (***) Only for BA 451, BA 531 |
| 39. Compensation hole | |
| 40. Recovery water tank (lifted) | |
| 41. Tank lifting handle | |
| 42. Lifted tank tie rod | |
| 43. Vacuum system motor cover | |
| 44. Vacuum system motor sound-deadening filter | |
| 45. Detergent tank (**) | |
| 46. Detergent tank filler plug (**) | |
| 47. Detergent tank handle (**) | |
| 48. Detergent feed hose (**) | |
| 49. Detergent pump (**) | |
| 50. Water pump (**) | |

GENERAL INFORMATION

MACHINE NOMENCLATURE (For BA 451, BA 451D, BA 531, BA 531D) (Continues)

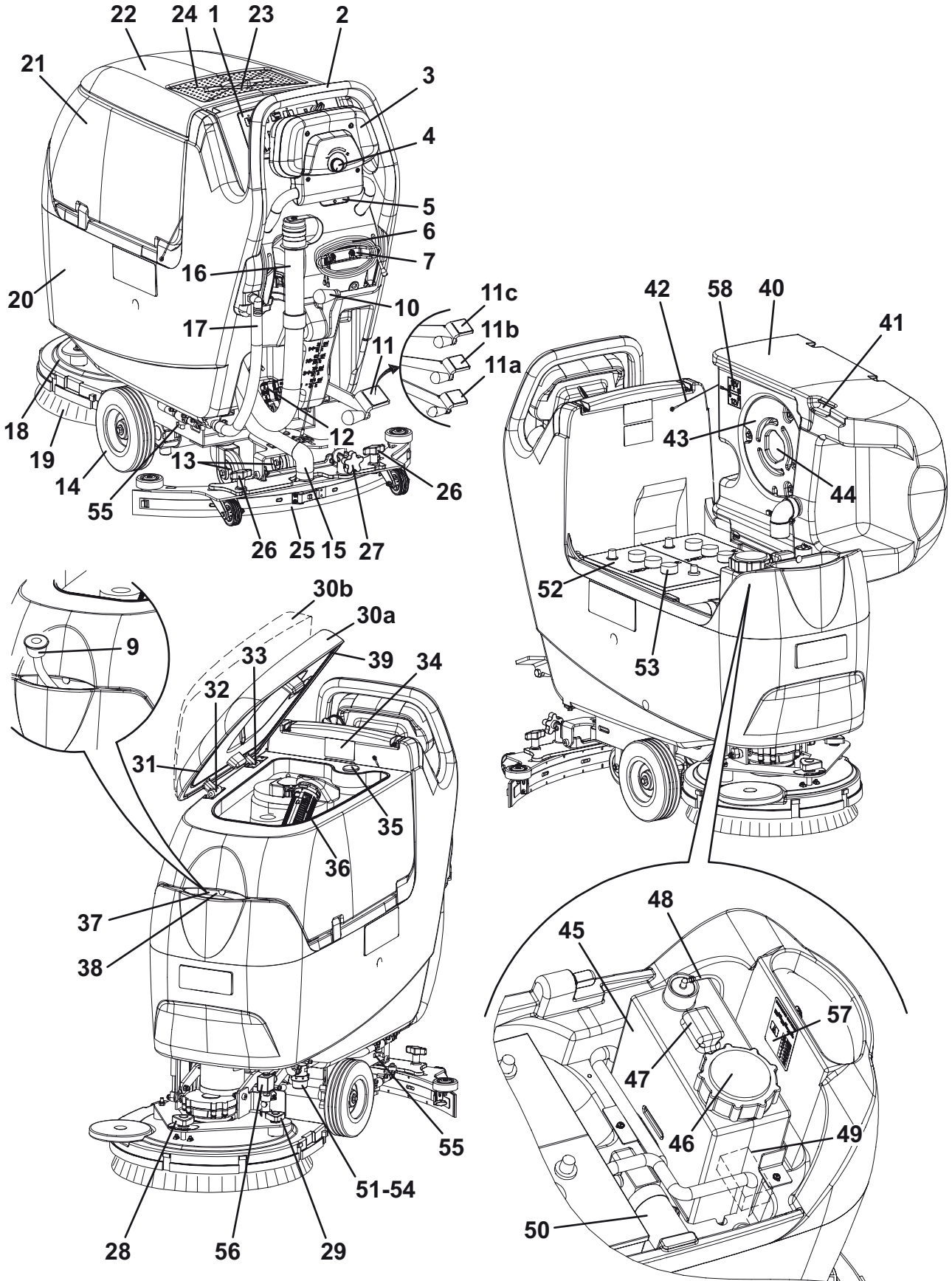

S301514

GENERAL INFORMATION

NOMENCLATURA DELLA MACCHINA (Per BA 451, BA 451D, BA 531, BA 531D) (Continua)

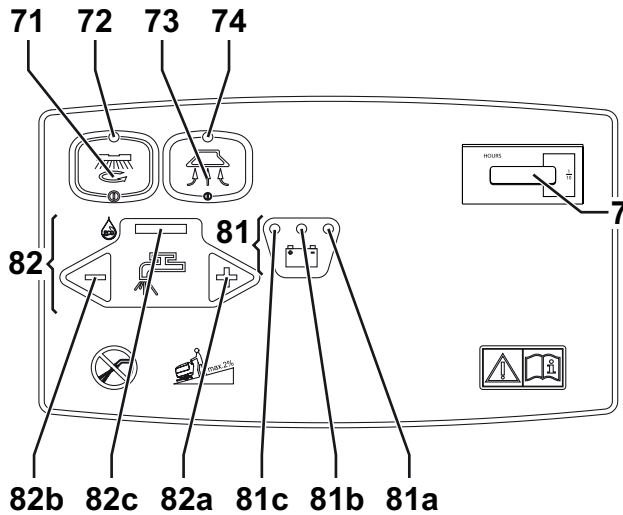

BA 451 / BA 531

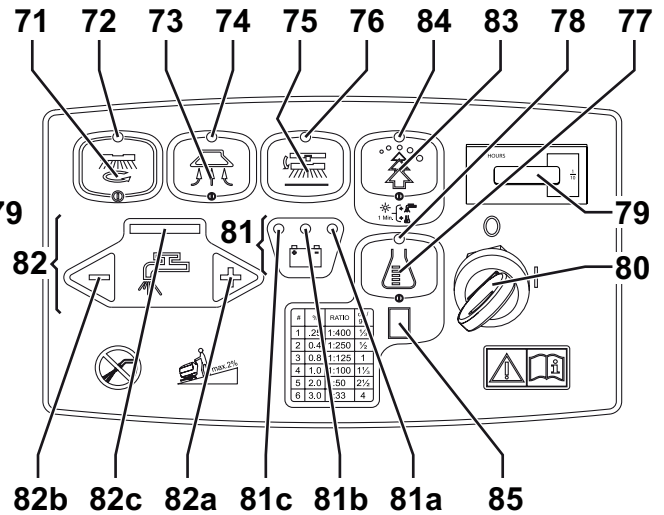

BA 451D / BA 531D

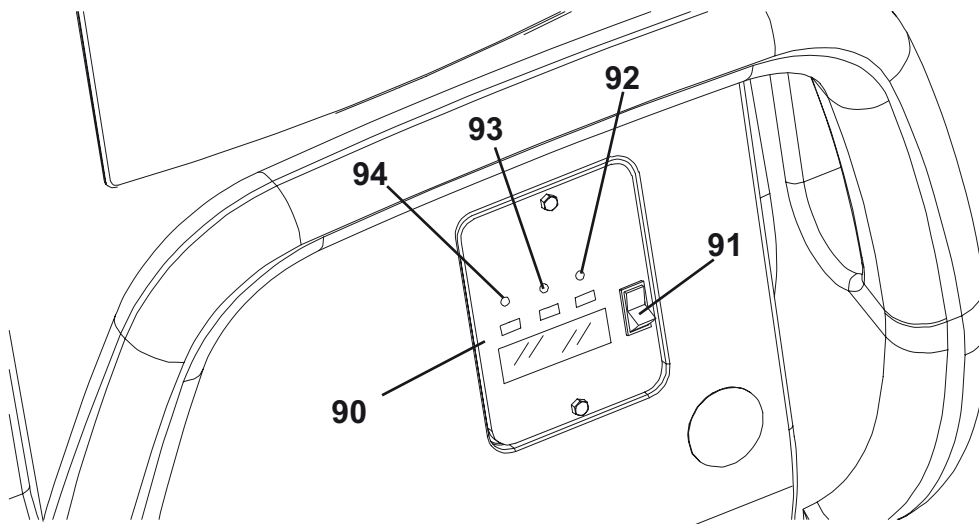

S301515

GENERAL INFORMATION

MACHINE NOMENCLATURE (For BA 551, BA 551D, BA 551CD, BA 611D)

Throughout this Manual you will find numbers in brackets – for example: (2). These numbers refer to the components indicated in these two nomenclature pages. Refer to these pages whenever you need to identify a component mentioned in the text.

- | | |
|--|--|
| 1. Control panel | 51. Clean water filter (**) |
| 2. Handlebar | 52. Batteries |
| 3. Drive paddle (*) | 53. Battery caps |
| 4. Speed adjuster (*) | 54. Solution filter |
| 5. Battery charger data inspection window (optional) | 55. Solution/clean water tap |
| 6. Battery charger cable (optional) | 56. Solenoid valve |
| 7. Battery charger cable holder (optional) | 57. Reference table for detergent proportioning (**) |
| 8. Solution/clean water rear filler neck | 58. Battery connection diagram |
| 9. Water removable filler hose (optional) | 71. Brush/pad-holder and vacuum system switch |
| 10. Squeegee lifting/lowering lever | 72. Brush/pad-holder and vacuum system switch warning led |
| 11. Deck lifting/lowering pedal | 73. Vacuum system switch |
| 11a. Pedal position when deck is lifted | 74. Vacuum system switch warning led |
| 11b. Pedal position when deck is lowered | 75. Brush/pad-holder release switch |
| 11c. Pedal position when the extra pressure function is on (if applicable) | 76. Brush/pad-holder release switch warning led |
| 12. Battery connector (red). This connector also works as EMERGENCY switch, to stop immediately all functions. | 77. Detergent flow control switch (**) |
| 13. Rear steering wheel | 78. Detergent flow control switch warning led |
| 14. Front wheels on fixed axle | 79. Hour counter (**) |
| 15. Squeegee vacuum hose | 80. Ignition key (0 - 1) (*) |
| 16. Recovery water drain hose | 81. Battery charge indicator |
| 17. Solution/clean water drain and level check hose | 81a. Charged battery warning led (green) |
| 18a. Deck with one brush/pad-holder | 81b. Semi-discharged battery warning led (yellow) |
| 18b. Deck with two brushes/pad-holders | 81c. Discharged battery warning led (red) |
| 18c. Deck with two cylindrical brushes | 82. Washing water flow control switches |
| 19a. Brush/pad-holder with pad | 82a. Flow increase switch |
| 19b. Cylindrical brushes | 82b. Flow decrease switch |
| 20. Solution/clean water tank | 82c. Washing water flow indicator |
| 21. Recovery water tank | 83. EcoFlex™ system switch (**) |
| 22. Recovery water tank cover | 84. EcoFlex™ system warning led (**): |
| 23. Can holder | • Led ON - EcoFlex™ system enabled |
| 24. Document retainer (optional) | • Led FLASHES - temporary override state |
| 25. Squeegee | 85. Detergent flow level display (**) |
| 26. Squeegee mounting handwheels | 90. Electronic battery charger |
| 27. Squeegee balance adjusting handwheel | 91. Lead (WET) or gel (GEL) battery selector |
| 28. Machine straight forward movement adjusting handwheel (***) | 92. Green warning led (ON: the battery charger is on and batteries are charged) |
| 29. Machine forward speed adjustment handwheel (***) | 93. Yellow warning led (ON: the battery charger is on and batteries are semi-discharged) |
| 30a. Recovery water tank cover (opened to be cleaned) | 94. Red warning led (ON: the battery charger is on and it is charging the batteries) |
| 30b. Recovery water tank cover (completely opened) | |
| 31. Tank cover gasket | (*) Only for BA 551D, BA 551CD, BA 611D |
| 32. Cover movable retaining plate | (**) Only for machines equipped with EcoFlex™ system (optional) |
| 33. Cover fixed retaining plate | (***) Only for BA 551 |
| 34. Serial number plate/technical data/conformity certification | |
| 35. Plug for squeegee vacuum hose cleaning | |
| 36. Vacuum grid with automatic shut-off float | |
| 37. Solution front filler neck | |
| 38. Foam filter | |
| 39. Compensation hole | |
| 40. Recovery water tank (open) | |
| 41. Tank lifting handle | |
| 42. Lifted tank tie rod | |
| 43. Vacuum system motor cover | |
| 44. Vacuum system motor sound-deadening filter | |
| 45. Detergent tank (**) | |
| 46. Detergent tank filler plug (**) | |
| 47. Detergent tank handle (**) | |
| 48. Detergent feed hose (**) | |
| 49. Detergent pump (**) | |
| 50. Water pump (**) | |

GENERAL INFORMATION

MACHINE NOMENCLATURE (For BA 551, BA 551D, BA 551CD, BA 611D) (Continues)

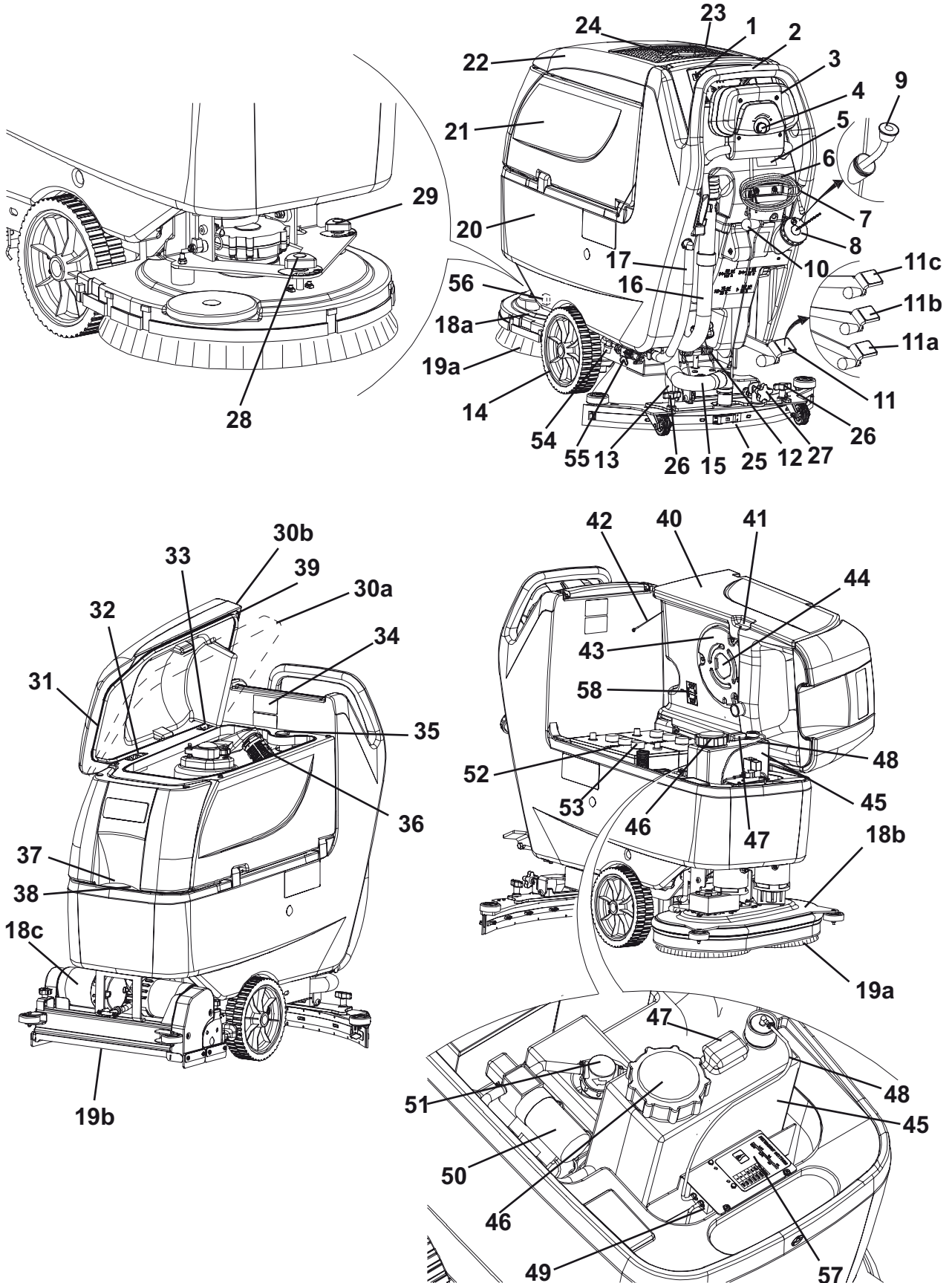

S301516

GENERAL INFORMATION

MACHINE NOMENCLATURE (For BA 551, BA 551D, BA 551CD, BA 611D) (Continues)

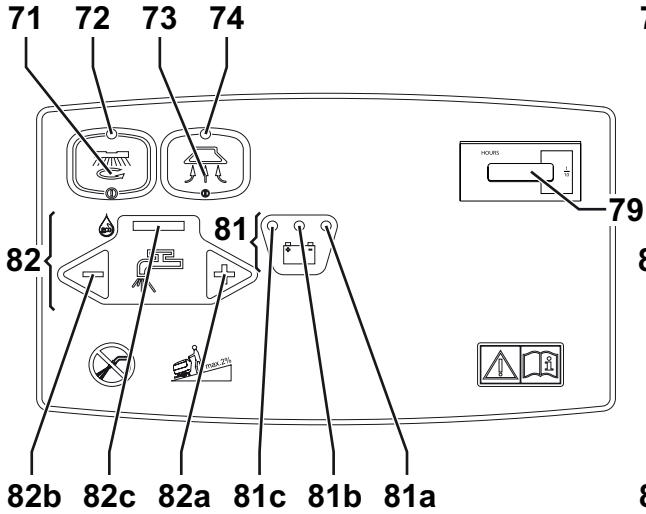

BA 511

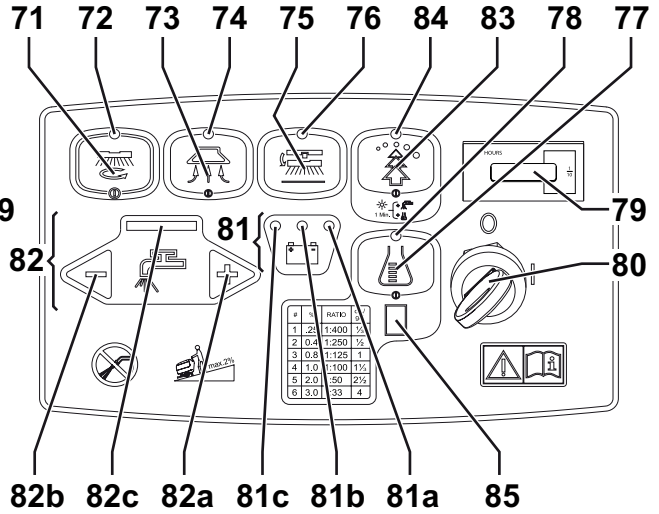

BA 551D / BA 551CD / BA 611D

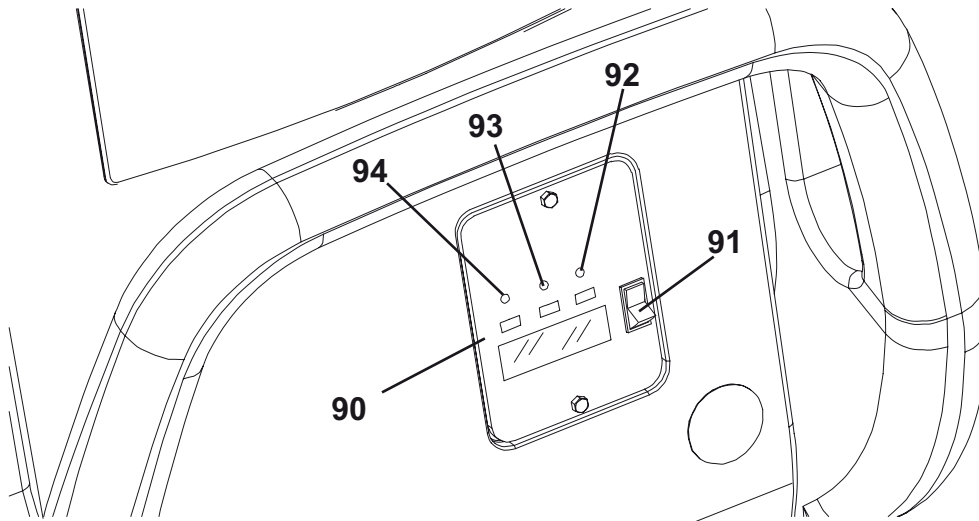

S301517

GENERAL INFORMATION**MACHINE NOMENCLATURE (For CA 451, CA 531)**

Throughout this Manual you will find numbers in brackets – for example: (2). These numbers refer to the components indicated in these two nomenclature pages. Refer to these pages whenever you need to identify a component mentioned in the text.

1. Control panel
2. Handlebar
9. Water removable filler hose (optional)
10. Squeegee lifting/lowering lever
11. Deck lifting/lowering pedal
- 11a. Pedal position when deck is lifted
- 11b. Pedal position when deck is lowered
13. Rear steering wheels
14. Front wheels on fixed axle
15. Squeegee vacuum hose
16. Recovery water drain hose
17. Solution drain and level check hose
18. Brush/pad-holder deck
19. Brush/pad-holder with pad
20. Solution tank
21. Recovery water tank
22. Recovery water tank cover
23. Can holder
24. Document retainer (optional)
25. Squeegee
26. Squeegee mounting handwheels
27. Squeegee balance adjusting handwheel
28. Machine straight forward movement adjusting handwheel
29. Machine forward speed adjustment handwheel
- 30a. Recovery water tank cover (opened to be cleaned)
- 30b. Recovery water tank cover (completely opened)
31. Tank cover gasket
32. Cover movable retaining plate
33. Cover fixed retaining plate
34. Serial number plate/technical data/conformity certification
35. Plug for squeegee vacuum hose cleaning
36. Vacuum grid with automatic shut-off float
37. Solution filler neck
38. Foam filter
39. Compensation hole
40. Recovery water tank (open)
41. Tank lifting handle
42. Lifted tank tie rod
43. Vacuum system motor cover
44. Vacuum system motor sound-deadening filter
54. Solution filter
55. Solution tap
56. Solenoid valve
59. Power supply cable
60. Power supply cable holder
61. Recovery water tank retaining plate
62. Brush/pad-holder switch
63. Vacuum system switch
64. Counterweight
79. Hour counter (optional)
82. Washing water flow control switches
- 82a. Flow increase switch
- 82b. Flow decrease switch
- 82c. Solution flow indicator

GENERAL INFORMATION

MACHINE NOMENCLATURE (For CA 451, CA 531) (Continues)

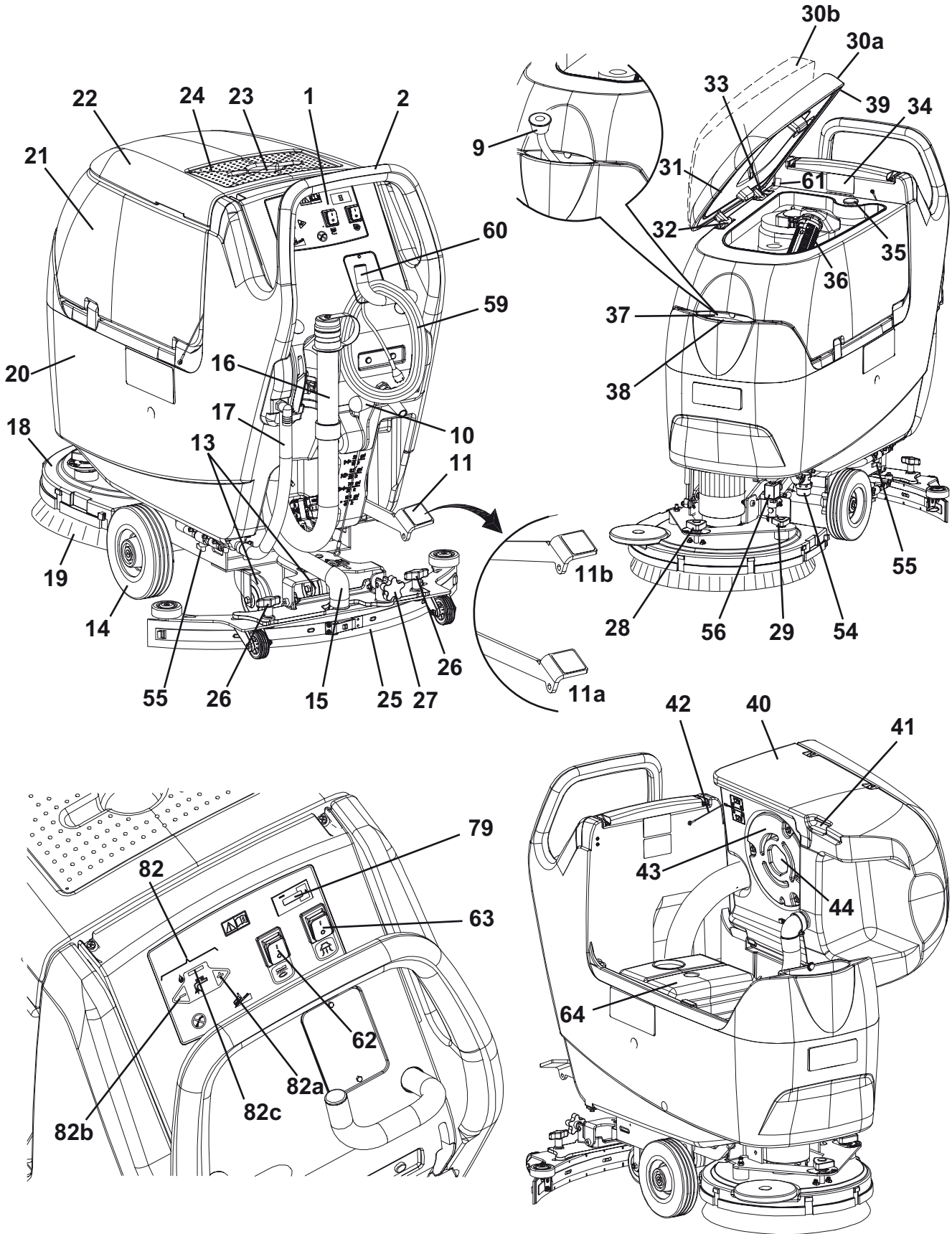

S301518

GENERAL INFORMATION**MACHINE NOMENCLATURE (For CA 551)**

Throughout this Manual you will find numbers in brackets – for example: (2). These numbers refer to the components indicated in these two nomenclature pages. Refer to these pages whenever you need to identify a component mentioned in the text.

1. Control panel
2. Handlebar
8. Solution rear filler neck
9. Water removable filler hose (optional)
10. Squeegee lifting/lowering lever
11. Deck lifting/lowering pedal
- 11a. Pedal position when deck is lifted
- 11b. Pedal position when deck is lowered
13. Rear steering wheel
14. Front wheels on fixed axle
15. Squeegee vacuum hose
16. Recovery water drain hose
17. Solution drain and level check hose
18. Brush/pad-holder deck
19. Brush/pad-holder with pad
20. Solution tank
21. Recovery water tank
22. Recovery water tank cover
23. Can holder
24. Document retainer (optional)
25. Squeegee
26. Squeegee mounting handwheels
27. Squeegee balance adjusting handwheel
28. Machine straight forward movement adjusting handwheel
29. Machine forward speed adjustment handwheel
- 30a. Recovery water tank cover (opened to be cleaned)
- 30b. Recovery water tank cover (completely opened)
31. Tank cover gasket
32. Cover movable retaining plate
33. Cover fixed retaining plate
34. Serial number plate/technical data/conformity certification
35. Plug for squeegee vacuum hose cleaning
36. Vacuum grid with automatic shut-off float
37. Solution front filler neck
38. Foam filter
39. Compensation hole
40. Recovery water tank (open)
41. Tank lifting handle
42. Lifted tank tie rod
43. Vacuum system motor cover
44. Vacuum system motor sound-deadening filter
54. Solution filter
55. Solution tap
56. Solenoid valve
59. Power supply cable
60. Power supply cable holder
61. Recovery water tank retaining plate
62. Brush/pad-holder switch
63. Vacuum system switch
64. Counterweight
79. Hour counter (optional)
82. Washing water flow control switches
- 82a. Flow increase switch
- 82b. Flow decrease switch
- 82c. Washing water flow indicator

GENERAL INFORMATION

MACHINE NOMENCLATURE (For CA 551) (Continues)

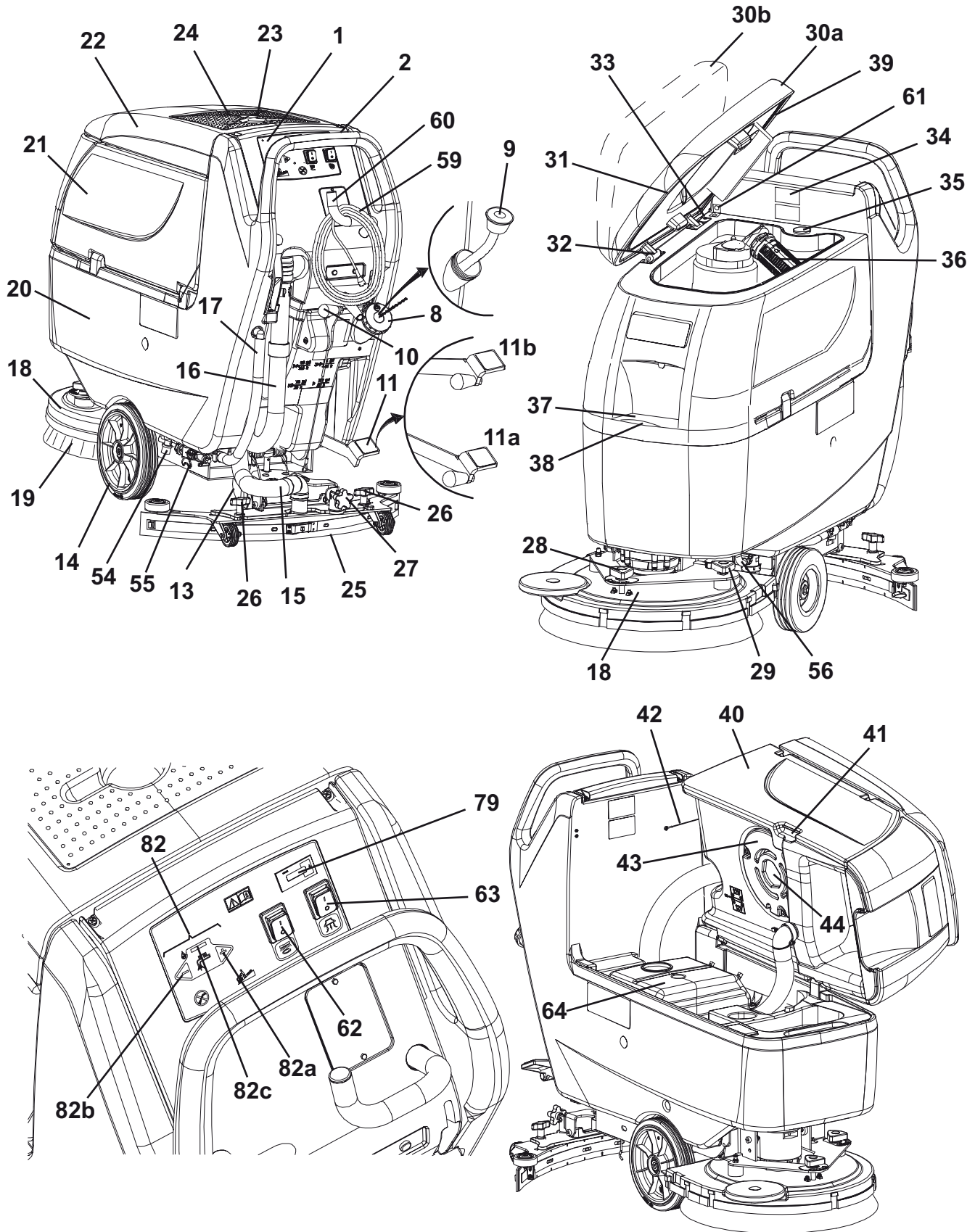

S301519

SOLUTION/CLEAN WATER SUPPLY SYSTEM

SOLUTION/CLEAN WATER SUPPLY SYSTEM

SOLUTION/CLEAN WATER TANK AND SUPPLY SYSTEM CLEANING (All models)

1. Drive the machine to the appointed solution disposal area.
2. - (For **BA 451D**, **BA 531D**, **BA 551D**, **BA 551CD**, **BA 611D**) Turn the ignition key (80) to "0".
- (For **BA 451**, **BA 531**, **BA 551**) Turn off the switches (71) and (73).
- (For **CA 451**, **CA 531**, **CA 551**) Disconnect the power supply cable (59) from the electrical mains.
3. Empty the solution/clean water tank (20) with the hose (17).
4. Start the machine (as shown in the User Manual) and keep it running until the solution/clean water tank is completely empty.
5. - (For **BA 451D**, **BA 531D**, **BA 551D**, **BA 551CD**, **BA 611D**) Turn the ignition key (80) to "0".
- (For **BA 451**, **BA 531**, **BA 551**) Turn off the switches (71) and (73).
- (For **CA 451**, **CA 531**, **CA 551**) Disconnect the power supply cable (59) from the electrical mains.
6. Clean the tank (20) with clean water.
7. Start the machine (as shown in the User Manual) and keep it running until the solution/clean water tank is completely empty.
8. Clean the solution filter (see the following procedure).

SOLUTION FILTER CLEANING (For **BA 451**, **BA 451D**, **BA 531**, **BA 531D**, **CA 451**, **CA 531**, without EcoFlex™ system)

1. Drive the machine on a level floor.
2. - (For **BA 451D**, **BA 531D**) Turn the ignition key (80) to "0".
- (For **BA 451**, **BA 531**) Turn off the switches (71) and (73).
- (For **CA 451**, **CA 531**) Disconnect the power supply cable (59) from the electrical mains.
3. Close the solution tap (A) under the machine left lower side. The tap (A) is closed when it is on the position (B) and it is open when it is on the position (C).
4. Remove the transparent cover (D), then remove the filter strainer (E). Clean and install them on the support (F).



NOTE

The filter strainer (E) must be correctly positioned on the housing (G) of the support (F).

5. Open the tap (A).

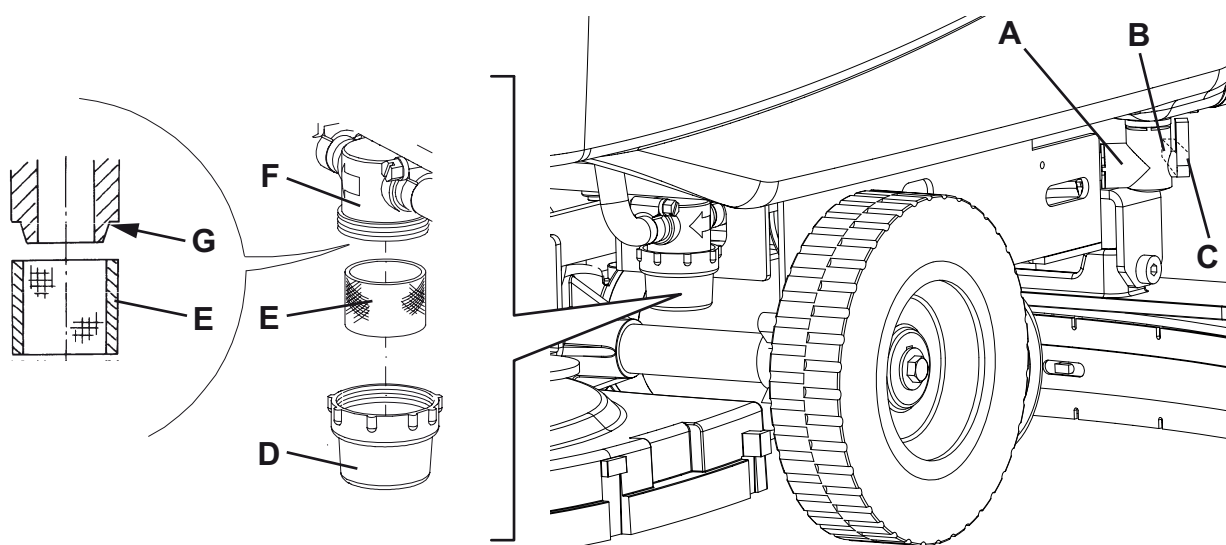

S301520

SOLUTION/CLEAN WATER SUPPLY SYSTEM

SOLUTION FILTER CLEANING (For BA 551, BA 551D, BA 551CD, BA 611D, CA 551, without EcoFlex™ system)

1. Drive the machine on a level floor.
2. - (For **BA 551D**, **BA 551CD**, **BA 611D**) Turn the ignition key (80) to "0".
- (For **BA 551**) Turn off the switches (71) and (73).
- (For **CA 551**) Disconnect the power supply cable (59) from the electrical mains.
3. Close the solution tap (A) under the machine left lower side. The tap (A) is closed when it is on the position (B) and it is open when it is on the position (C).
4. Remove the transparent cover (D), then remove the filter strainer (E). Clean and install them on the support (F).

NOTE

The filter strainer (E) must be correctly positioned on the housing (G) of the support (F).

5. Open the tap (A).

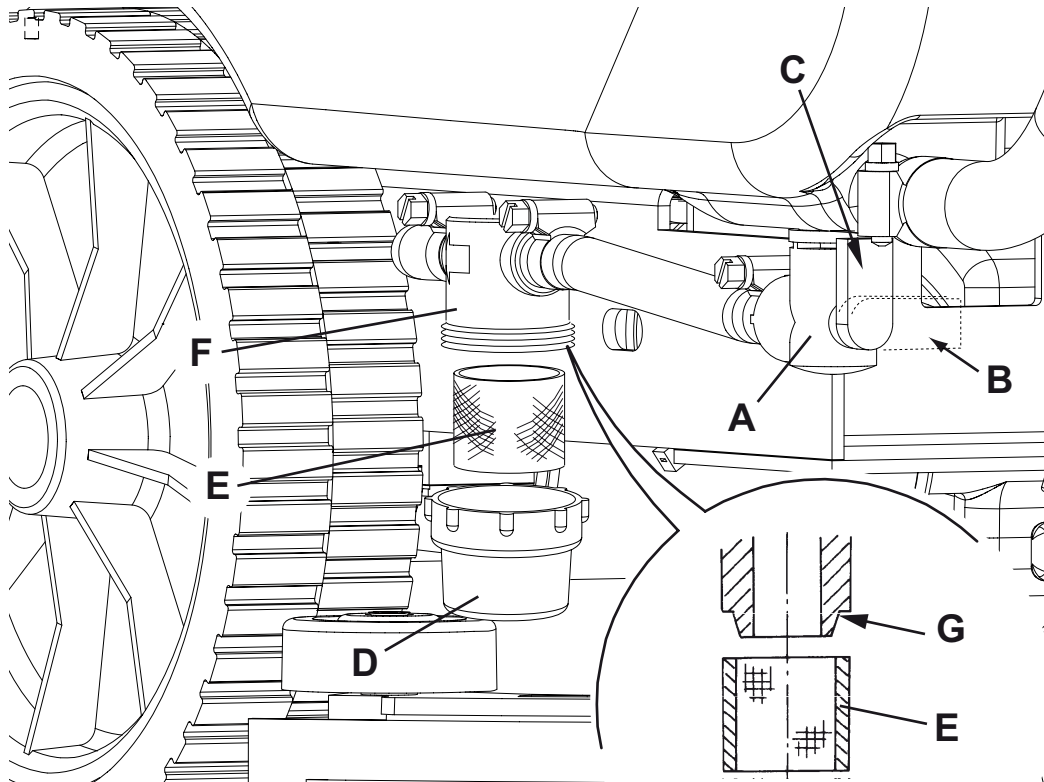

S301521

SOLUTION/CLEAN WATER SUPPLY SYSTEM**SOLENOID VALVE DISASSEMBLY/ASSEMBLY (For BA 451, BA 451D, BA 531, BA 531D, CA 451, CA 531)****Disassembly**

1. Remove the brush.
2. Lower the deck by pressing the pedal (11).
3. Remove the screw (A), disconnect the connector (B) and recover the gasket.
4. Disconnect the union (C) from the solenoid valve (D) and recover the gasket.
5. Remove the screws (E).
6. Slightly lift the solenoid valve (D), disconnect the union (F) and recover the gasket.
7. Recover the solenoid valve (D).

Assembly

8. Assemble the components in the reverse order of disassembly.

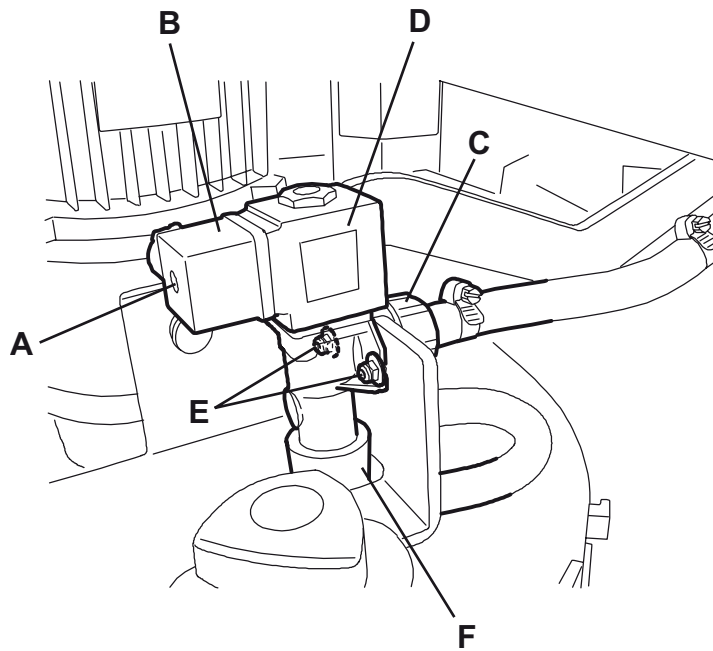

S301522

SOLUTION/CLEAN WATER SUPPLY SYSTEM

SOLENOID VALVE DISASSEMBLY/ASSEMBLY (For BA 551, BA 551D, BA 551CD, BA 611D, CA 551)

Disassembly

1. (For machines with brushes/pad-holders) Remove the brushes/pad-holders.
2. Lower the deck by pressing the pedal (11).
3. (For machines without EcoFlex™ system) Loosen the clamp (A) and disconnect the hoses (B) from the filter assembly (C).
4. Disconnect the union (D) from the solenoid valve (E) and recover the gasket.
5. Remove the screw (F), disconnect the connector (G) and recover the gasket.
6. Remove the nuts (H).
7.
 - (For machines without EcoFlex™ system) Remove the solenoid valve (E) with the hoses (B). If necessary, separate the hoses (B) from the solenoid valve.
 - (For machines with EcoFlex™ system) Move the solenoid valve (E) and disconnect it from the union (I).

Assembly

8. Assemble the components in the reverse order of disassembly.

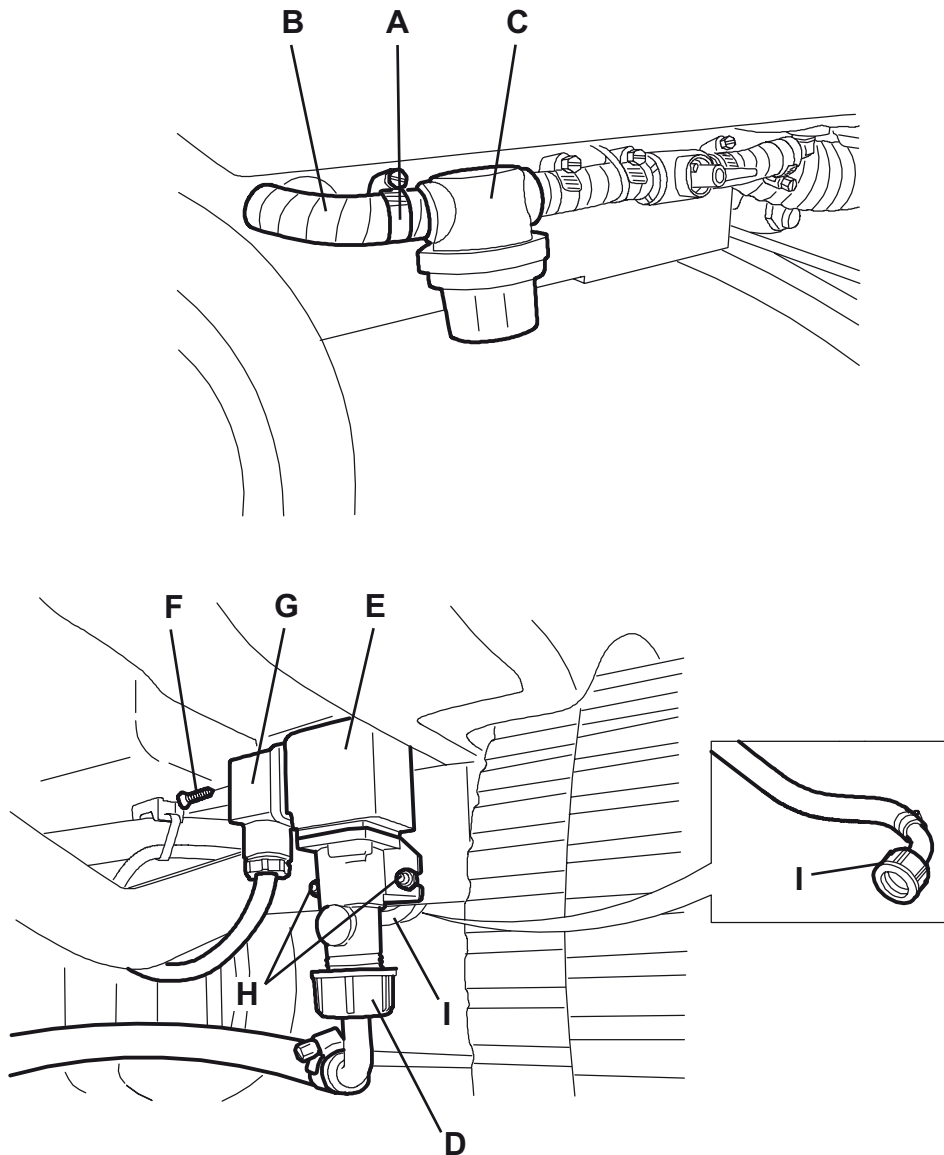

S301523

SOLUTION/CLEAN WATER SUPPLY SYSTEM**TROUBLESHOOTING****SMALL AMOUNT OF SOLUTION OR NO SOLUTION REACHES THE BRUSH****Possible causes**

1. The solution/clean water filter is clogged/dirty (clean).
2. The solution/clean water tap is stuck closed (replace).
3. The solenoid valve is broken or there is an open in the electrical connection (replace the solenoid valve/repair the electrical connection).
4. There is debris in the solution tank clogging the output hole (clean the tank).
5. There are debris in the solution/clean water hoses clogging the flow (clean the hoses).

THE SOLUTION/CLEAN WATER REACHES THE BRUSH ALSO WHEN THE MACHINE IS OFF**Possible causes**

1. There is dirt or calcium deposit on the solenoid valve gasket (clean).
2. The solenoid valve is broken (replace).

ECOFLEX™ SYSTEM**ECOFLEX™ SYSTEM****CLEAN WATER FILTER CLEANING (For BA 451D, BA 531D)**

1. Drive the machine on a level floor.
2. Turn the ignition key (80) to "0".
3. Close the clean water tap (A) under the machine left lower side. The tap (A) is closed when it is on the position (B) and it is open when it is on the position (C).
4. Remove the transparent cover (D), then remove the filter strainer (E). Clean and install them on the support (F).

**NOTE:**

The filter strainer (E) must be correctly positioned on the housing (G) of the support (F).

5. Open the tap (A).

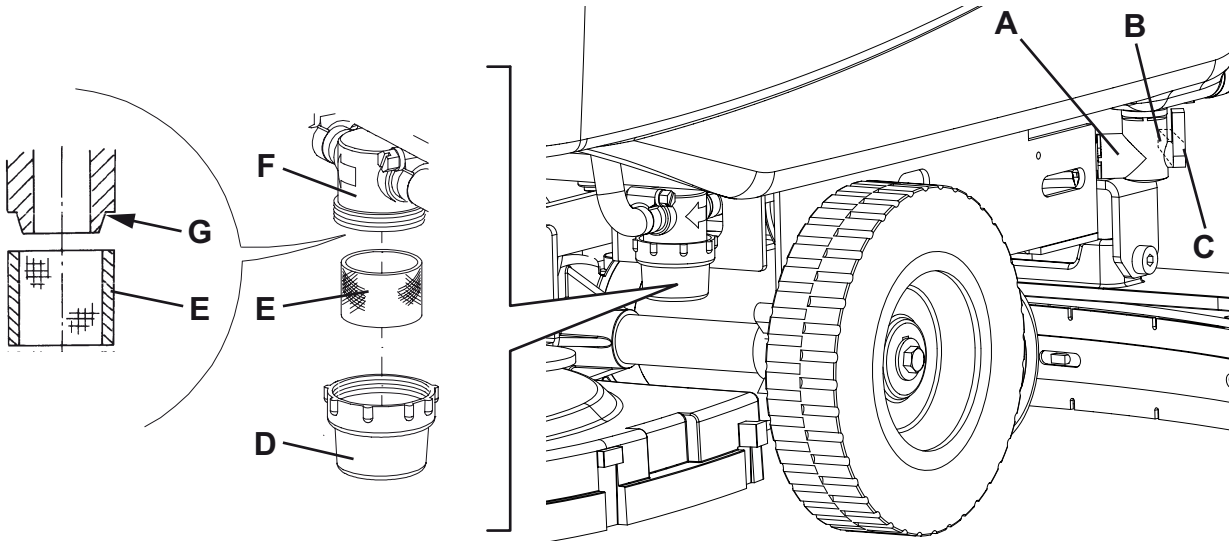

S301520

CLEAN WATER FILTER CLEANING (For BA 551D, BA 551CD, BA 611D)

1. Drive the machine on a level floor.
2. Turn the ignition key (80) to "0".
3. Open the cover (22) and check that the recovery water tank (21) is empty, otherwise empty it with the drain hose (16).
4. Grasp the handle (41) and carefully lift the tank (40).
5. Slightly lift the hoses (A), then, operating on the clean water filter assembly (F), unscrew the transparent cover (B) and remove the filter strainer (C). Clean and install them on the support (D).

**NOTE:**

The filter strainer (C) must be correctly positioned on the housing (E) of the support (D).

1. Install the hoses (A) and the filter assembly (F).

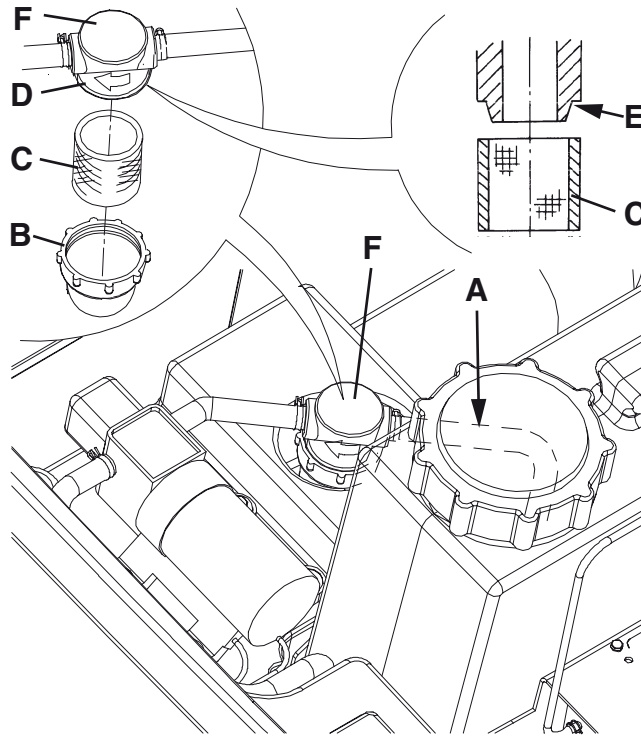

S301524

ECOFLEX™ SYSTEM

DETERGENT TANK CLEANING (For BA 451D, BA 531D, BA 551D, BA 551CD, BA 611D)

1. Drive the machine to the appointed detergent disposal area.
2. Turn the ignition key (80) to "0".
3. Open the cover (22) and check that the recovery water tank (21) is empty, otherwise empty it with the drain hose (16). Close the cover (22).
4. Grasp the handle (41) and carefully lift the tank (40).
5. Unscrew the union and remove the hose (48) from the tank (45).
6. Remove the tank (45) by releasing it from the fasteners.
7. Unscrew the plug (A) and wash the detergent tank (B) in the appointed detergent disposal area.
If necessary, remove the supply hose (C) and clean it, especially in area of the vacuum end pipe (D). Install the supply hose (C).
8. Check that the plug vent hole (E) is not clogged, by driving in air and checking if it comes out from the outer hole (F). If necessary clean the hole with compressed air. Install the plug (A).
9. Install the tank (45) and connect it to the hose (48).
10. When the detergent tank and the supply hose have been drained, the EcoFlex™ system must be drained too (see the procedure in the following paragraph).

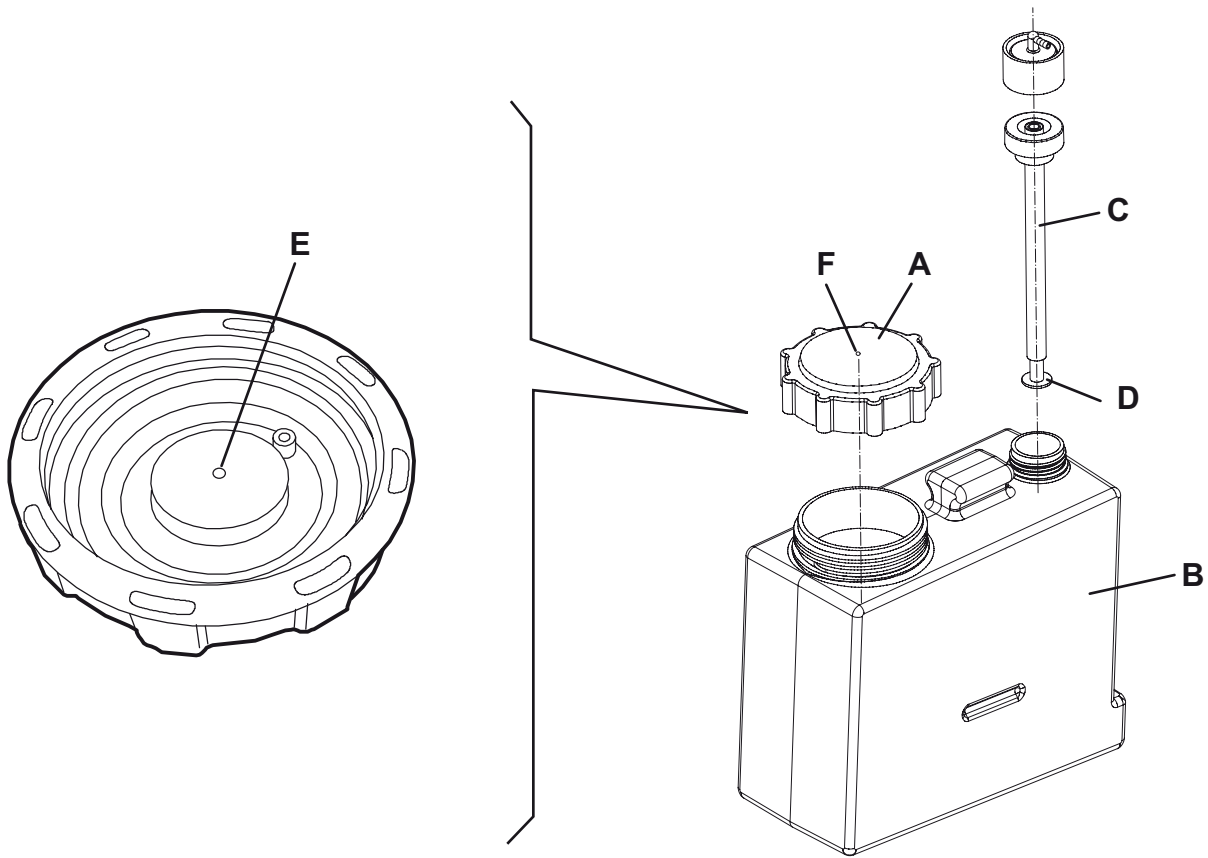

S301525

ECOFLEX™ SYSTEM**ECOFLEX™ SYSTEM DRAINING (For BA 451D, BA 531D, BA 551D, BA 551CD, BA 611D)**

1. Clean the detergent tank, then remove the detergent remained in the hoses and in the pump.
2. Grasp the handle (41) and carefully lower the tank (40).
3. Turn on the machine by turning the ignition key (80) to "I".
4. Turn on the EcoFlex™ system by pressing the switch (77). Check that the switch warning led (78) turns on.
5. Press the switches (77) and (82a) at the same time, until the switch warning led (78) starts flashing (after about 5 seconds).
6. Release the switches and wait for the warning led (78) to stop flashing and for the vacuum system to turn on.
7. Collect the detergent remained on the floor.
8. Turn the ignition key (80) to "0".
9. Grasp the handle (41) and carefully lift the tank (40), then check that the hose (48) is empty, otherwise perform steps 3 to 9 again.

**NOTE:**

The draining cycle lasts about 30 seconds, then the vacuum function automatically turns on, which allows to remove the detergent remained.

The draining cycle can also be performed with the detergent tank (45) full of water, thus cleaning the system thoroughly. It is advisable to perform the draining cycle when the EcoFlex™ system is really dirty/encrusted because the machine has not been used/cleaned for a long time.

The draining cycle can be performed also to quickly fill the detergent supply hose when the tank (45) is full but the system is still empty.

If necessary, the draining cycle can be repeatedly performed.

ECOFLEX™ SYSTEM

WATER PUMP DISASSEMBLY/ASSEMBLY (For BA 451D, BA 531D, BA 551D, BA 551CD, BA 611D)

Disassembly

1. If the tank (21) contains recovery water:
 - Drive the machine to the appointed recovery water disposal area.
 - Turn the ignition key (80) to "0".
 - Empty the recovery water tank (21) with the hose (16).
2. Drive the machine on a level floor.
3. Turn the ignition key (80) to "0".
4. Grasp the handle (41) and carefully lift the tank (40).
5. Disconnect the connector (A).
6. Loosen the clamps (B) and disconnect the hoses (C) from the water pump (D).
7. Remove the screws (E).
8. Remove the water pump (D).

Assembly

9. Assemble the components in the reverse order of disassembly.

**NOTE:**

Figure showing BA 551D, BA 551CD, BA 611D

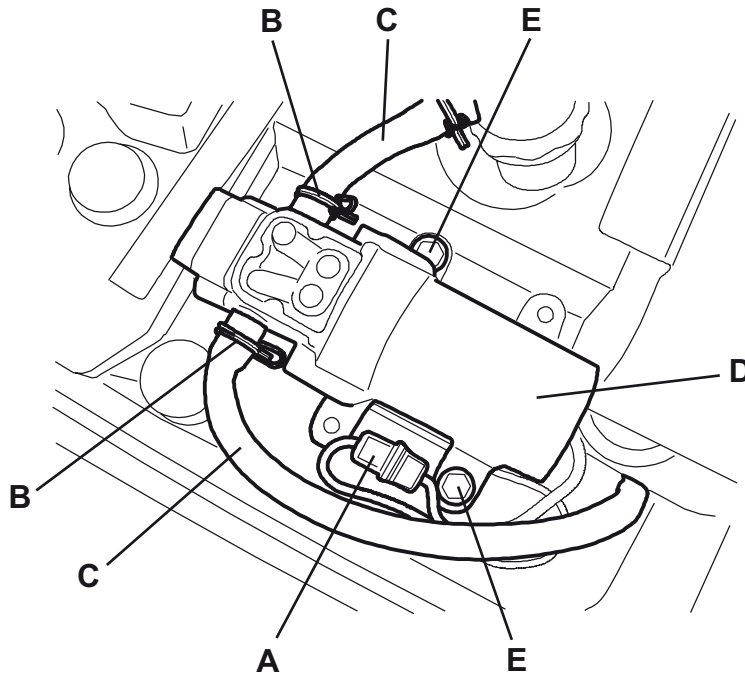

S301526

ECOFLEX™ SYSTEM**DETERGENT PUMP AND CHECK VALVE DISASSEMBLY/ASSEMBLY (For BA 451D, BA 531D)****Disassembly**

1. If the tank (21) contains recovery water:
 - Drive the machine to the appointed recovery water disposal area.
 - Turn the ignition key (80) to "0".
 - Empty the recovery water tank (21) with the hose (16).
2. Drive the machine on a level floor.
3. Turn the ignition key (80) to "0".
4. Grasp the handle (41) and carefully lift the tank (40).
5. Unscrew the union (A).
6. Remove the detergent tank (B).
7. Remove the screws (C).
8. Slightly lift the tank holder (D) and mark the position of the connectors (E) and (F) (to reinstall them correctly), which must be as follows:
 - Connector (E): white cable
 - Connector (F): blue cable
9. Disconnect the connectors (E) and (F) from the detergent pump (G).
10. Disconnect the hoses (H) from the relevant union.
11. Remove the screws (I) and recover the detergent pump (G) together with the hoses.
12. If necessary, disconnect the hoses (J) and (K) from the pump.
13. If necessary, to reinstall the components correctly, mark the position of the arrow (M), which must be as shown in the figure, and replace the check valve (L).

Assembly

14. Assemble the components in the reverse order of disassembly.

ECOFLEX™ SYSTEM

DETERGENT PUMP AND CHECK VALVE DISASSEMBLY/ASSEMBLY (For BA 451D, BA 531D) (Continues)

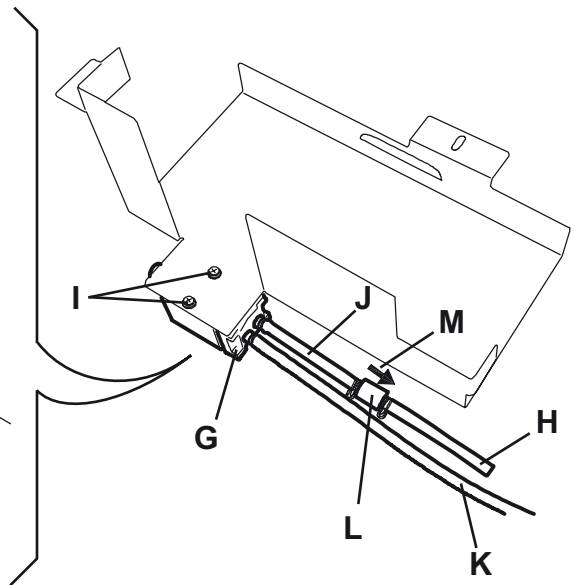
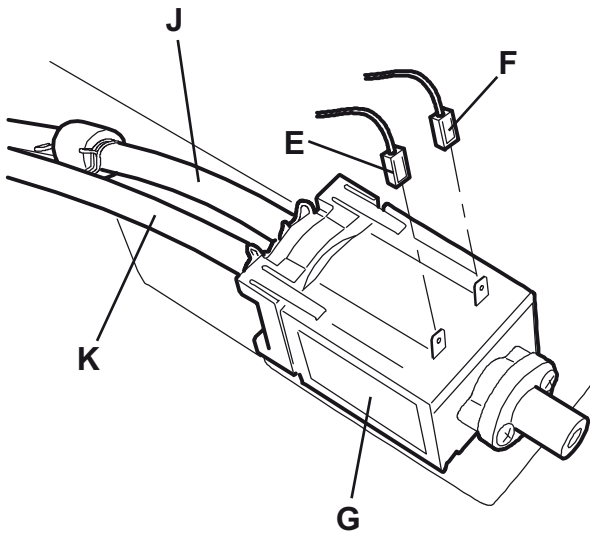
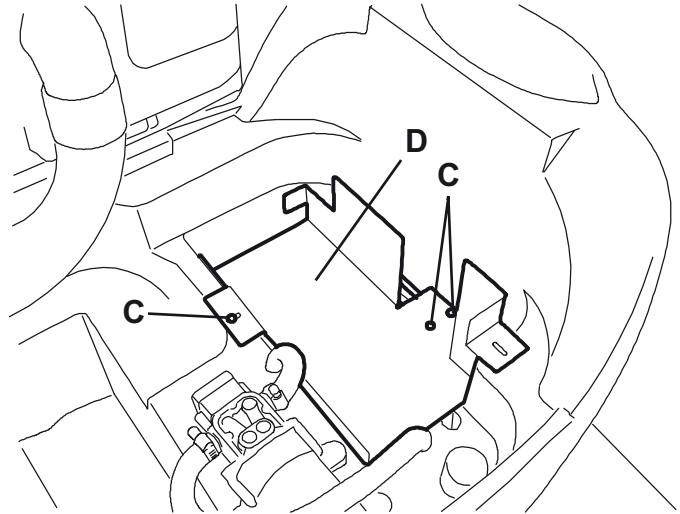
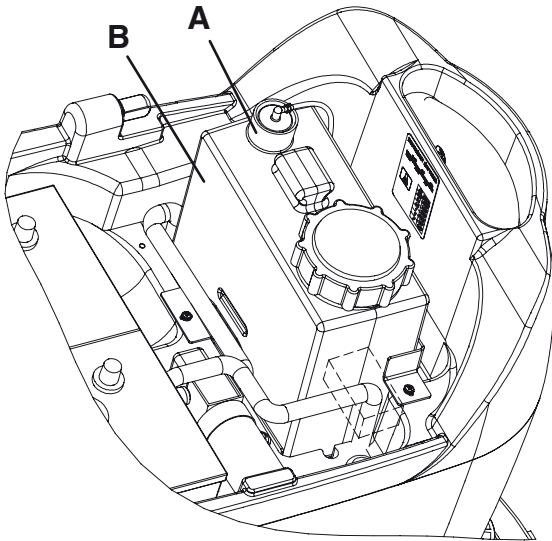

S301527

ECOFLEX™ SYSTEM**DETERGENT PUMP AND CHECK VALVE DISASSEMBLY/ASSEMBLY (For BA 551D, BA 551CD, BA 611D)****Disassembly**

1. If the tank (21) contains recovery water:
 - Drive the machine to the appointed recovery water disposal area.
 - Turn the ignition key (80) to "0".
 - Empty the recovery water tank (21) with the hose (16).
2. Drive the machine on a level floor.
3. Turn the ignition key (80) to "0".
4. Grasp the handle (41) and carefully lift the tank (40).
5. Unscrew the union (A).
6. Remove the detergent tank (B).
7. Remove the screws (C).
8. Slightly lift the tank holder (D) and mark the position of the connectors (E) and (F) (to reinstall them correctly), which must be as follows:
 - Connector (E): white cable
 - Connector (F): blue cable
9. Disconnect the connectors (E) and (F) from the detergent pump (G).
10. Disconnect the hoses (H) from the relevant union.
11. Remove the screws (I) and recover the detergent pump (G) together with the hoses.
12. If necessary, disconnect the hoses (J) and (K) from the pump.
13. If necessary, mark the position of the arrow (M) (to reinstall the components correctly), which must be as shown in the figure, and replace the check valve (L).

Assembly

14. Assemble the components in the reverse order of disassembly.

ECOFLEX™ SYSTEM

DETERGENT PUMP AND CHECK VALVE DISASSEMBLY/ASSEMBLY (For BA 551D, BA 551CD, BA 611D) (Continues)

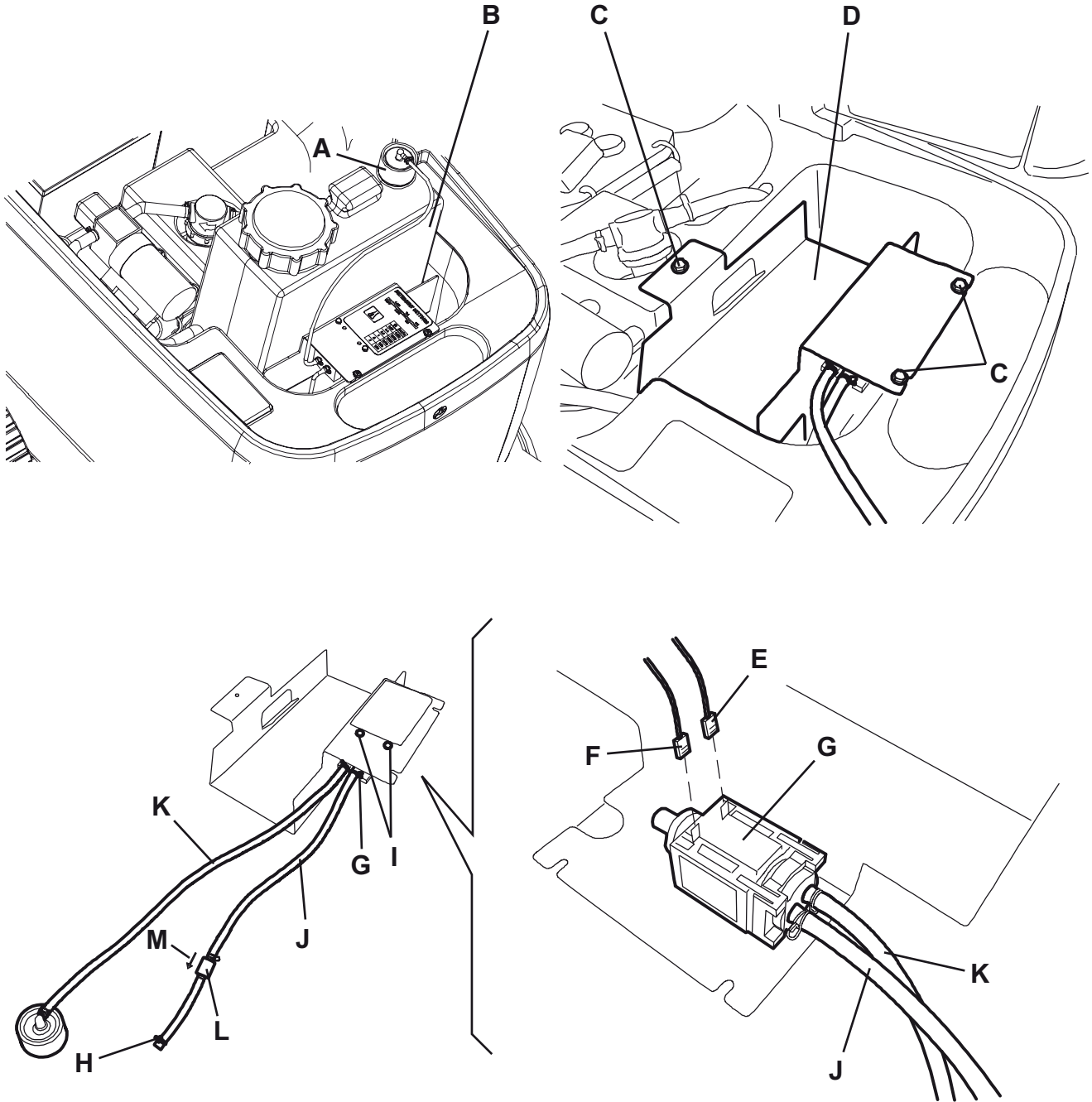

S301528

TROUBLESHOOTING

SMALL AMOUNT OF DETERGENT OR NO DETERGENT REACHES THE BRUSHES

Possible causes

1. The detergent flow percentage is too low (check/change the percentage as shown in the User Manual).
2. The hydraulic circuit upstream of the detergent pump is not triggered (check if the hose (48) is filled and, if necessary, perform one or more draining cycle, as shown in the relevant paragraph).
3. The pump is broken or there is an open in the electrical connection (replace the pump/repair the electrical connection).
4. There is debris in the detergent tank clogging the output hole (clean the tank).
5. There are debris in the detergent hoses clogging the detergent flow (clean the hoses).
6. The detergent flow control switch is malfunctioning (check that the warning led (78) turns on; if necessary, replace the function electronic board).
7. The function electronic board is not set for the operation with EcoFlex™ system (if present, remove the jumper wire (J4) behind the electronic board).
8. The function electronic board is faulty (replace).

THE DETERGENT REACHES THE BRUSHES ALSO WHEN THE MACHINE IS OFF

Possible causes

1. The pump is broken (replace).
2. The one-way valve is broken (replace).

THERE IS WATER IN THE DETERGENT TANK

Possible cause

1. The one-way valve is broken (replace).

THE ECOFLEX™ SYSTEM DOES NOT TURN ON WHEN PRESSING THE SWITCH (77) AND THE Warning led (78) DOES NOT TURN ON

Possible causes

1. The function electronic board is not set for the operation with EcoFlex™ system (if present, remove the jumper wire (J4) behind the electronic board).
2. The function electronic board is faulty (replace).

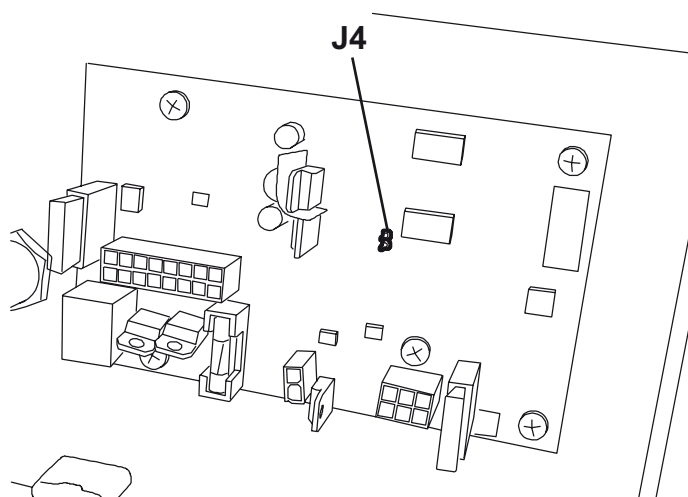

S301568

BRUSHING SYSTEM

BRUSHING SYSTEM/PAD CLEANING

**CAUTION!**

It is advisable to wear protective gloves when cleaning the brushes/pads because there may be sharp debris.

1. Remove the brushes/pads, as shown in the User Manual.
2. Clean and wash the brushes/pads with water and detergent.
3. Check that the brush/pads are integral and not excessively worn; otherwise replace them.
4. (For **BA 551CD**) Remove the debris container (A) by pulling it on one side with the handle (B). Empty and wash the debris container (A), and then install it by engaging it on the inside fasteners.

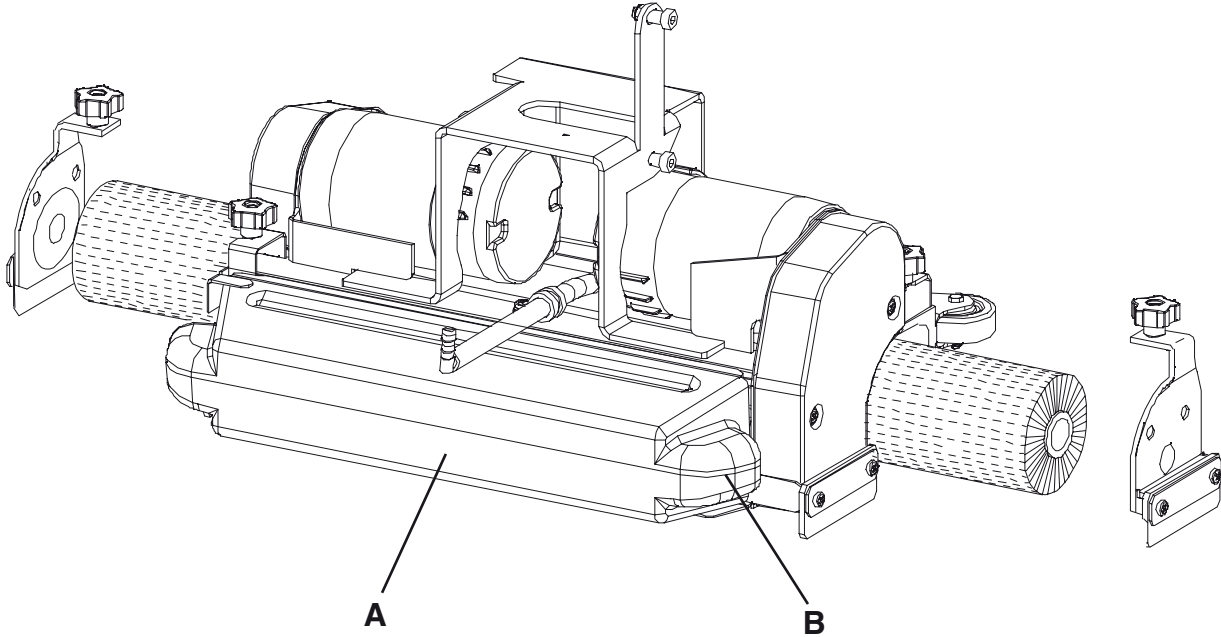

S301529

BRUSHING SYSTEM**BRUSH/PAD-HOLDER/CYLINDRICAL BRUSH DECK DISASSEMBLY/ASSEMBLY (For BA 451, BA 451D, BA 531, BA 531D)**

The machine can be equipped with either the brush/pad-holder deck or the cylindrical brush deck.

Disassembly

1. Drive the machine on a level floor.
2. Remove the brushes/pad-holders, as shown in the User Manual.
3. Lower the brush/pad-holder deck by pressing the pedal (11).
4. Remove the cotter pins (B), then remove the gas spring (A).
5. Disconnect the brush/pad-holder motor electrical connection (D).
6. Remove the screw (E) and disconnect the electrical connection (F).
7. Disconnect the solution hose connection (G).
8. Remove the screws (C), then remove the brush/pad-holder deck (H).

Assembly

9. Assemble the components in the reverse order of disassembly.

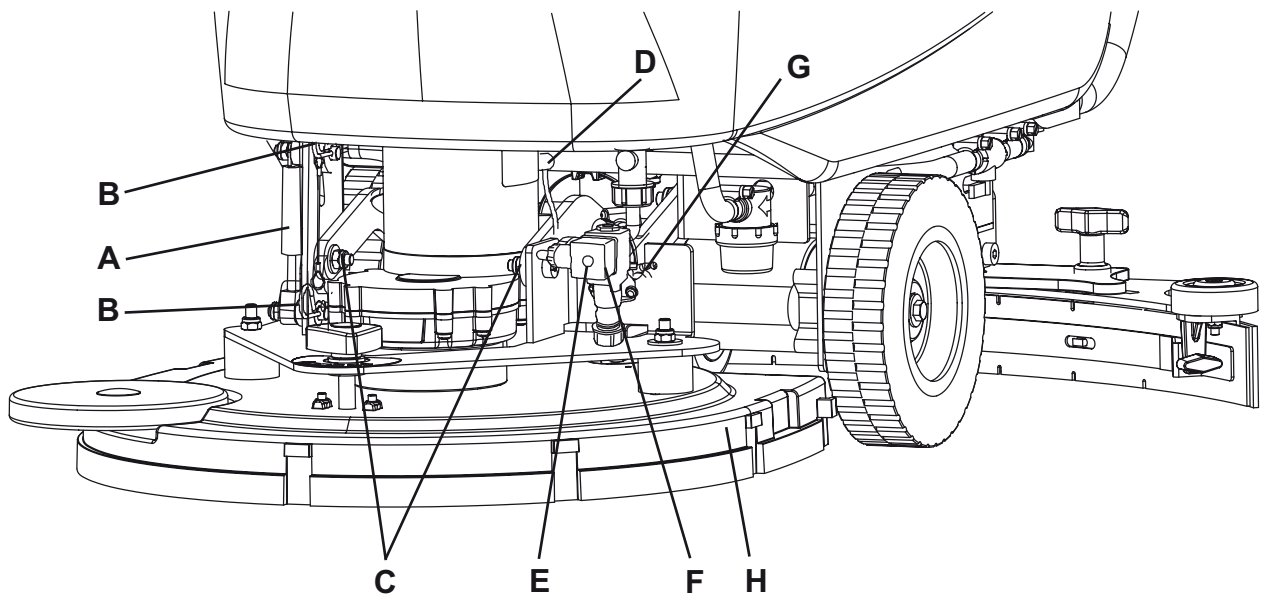

S301530

BRUSHING SYSTEM

BRUSH/PAD-HOLDER/CYLINDRICAL BRUSH DECK DISASSEMBLY/ASSEMBLY (For BA 551, BA 551D, BA 551CD, BA 611D)

The machine can be equipped with either the brush/pad-holder deck (18a and 18b) or the cylindrical brush deck (18c), according to the following procedures.



NOTE:

When the deck is installed/removed, it may be necessary to change the squeegee too, because they must have the same width. For correct matching of deck and squeegee, see the Squeegee Installation paragraph in the User Manual.

Disassembly

1. Drive the machine on a level floor.
2. Remove the brushes/pad-holders, as shown in the User Manual. Do not remove the cylindrical brushes.
3. Lower the brush/pad-holder deck by pressing the pedal (11).
4. Remove the cotter pins (B), then remove the gas spring (A), if present.
5. Disconnect the brush/pad-holder motor electrical connection (D).
6. Disconnect the solution hose connection (E).
7. Remove the screws (C), then remove the brush/pad-holder deck (F).

Assembly

1. Assemble the components in the reverse order of disassembly, and note the following:
 - When the machine is equipped with the cylindrical brush deck (18c), the gas spring (A) must not be installed.



NOTE:

Figure showing BA 551 with one brush

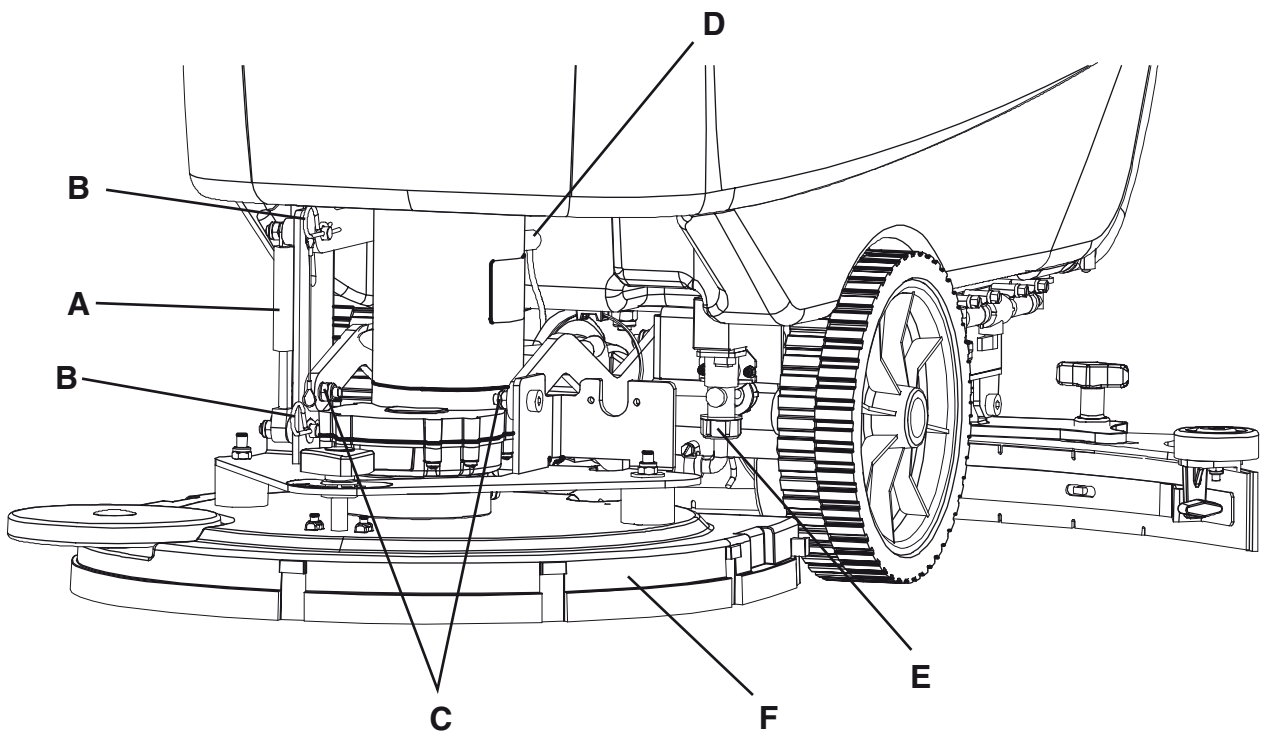

S301531

BRUSHING SYSTEM**BRUSH/PAD-HOLDER DECK DISASSEMBLY/ASSEMBLY (For CA 451, CA 531, CA 551)****Disassembly**

Drive the machine to the appointed disposal area, and empty the recovery water tank (21) with the hose (16).

1. Remove the brush/pad-holder, as shown in the User Manual.
2. Place the machine on a hoisting system (if available).
3. Otherwise, drive the machine on a level floor.
4. Disconnect the power supply cable (59) from the electrical mains.
5. Open the recovery water tank cover (22).
6. Remove the retaining plate (61) of the tank (40).
7. Grasp the handle (41) and carefully lift the tank (40).
8. If the power supply cable (59) is on the holder (60), remove it.
9. Move aside the recovery water drain hose (16).
10. Remove the screws (A) and carefully move the panel (B).
11. Disconnect the brush motor wiring harness connections (C) from the electronic board (D) (connections symbols: "F4" and "F5").
12. Open the brush motor wiring harness clamps (E).
13. Open the brush motor wiring harness clamps (F).
14. Lower the deck by pressing the pedal (11).
15. Disconnect the solution hose connection (G).
16. Remove the screws (H) and (P), then remove the brush/pad-holder deck (I) with the relevant motor and wiring harness.

Assembly

17. Assemble the components in the reverse order of disassembly, and note the following:
 - When installing the deck (I) on the machine, use the handwheel (Q) to centre the screw hole (P).

**WARNING!**

When the maintenance/repair procedure is completed, the tank (40) must always be locked with the plate (61).

**NOTE:**

Figure showing CA 451.

BRUSHING SYSTEM

BRUSH/PAD-HOLDER DECK DISASSEMBLY/ASSEMBLY (For CA 451, CA 531, CA 551) (Continues)

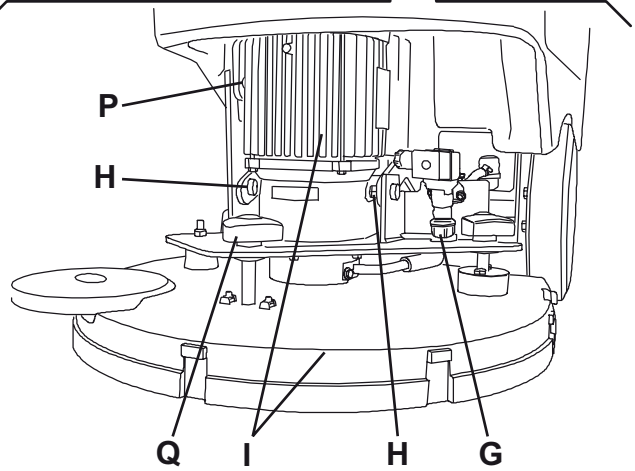
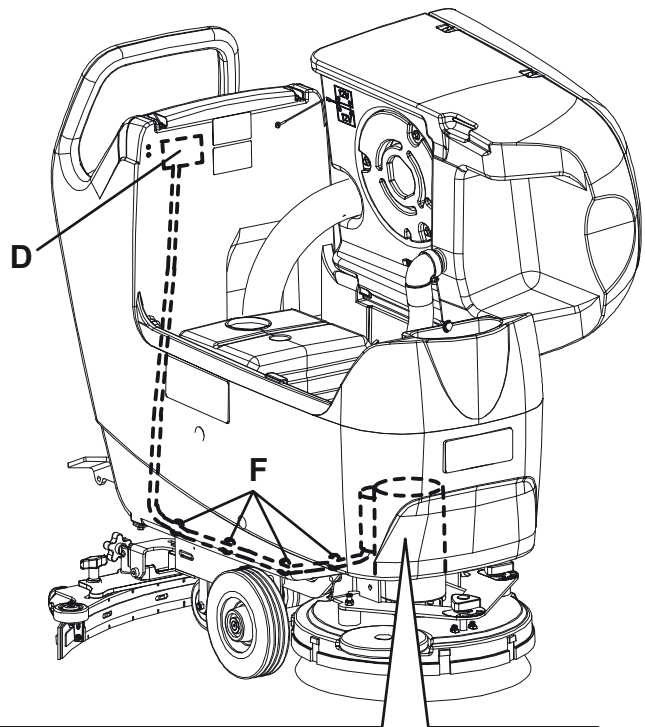
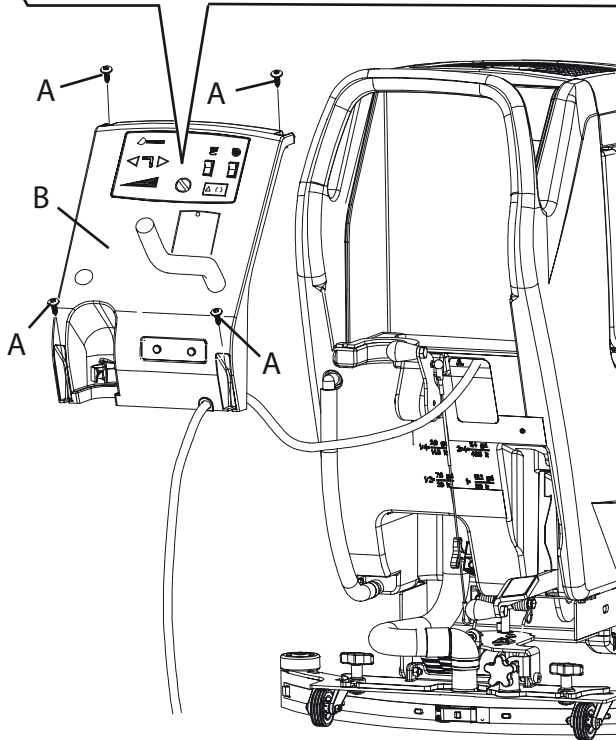
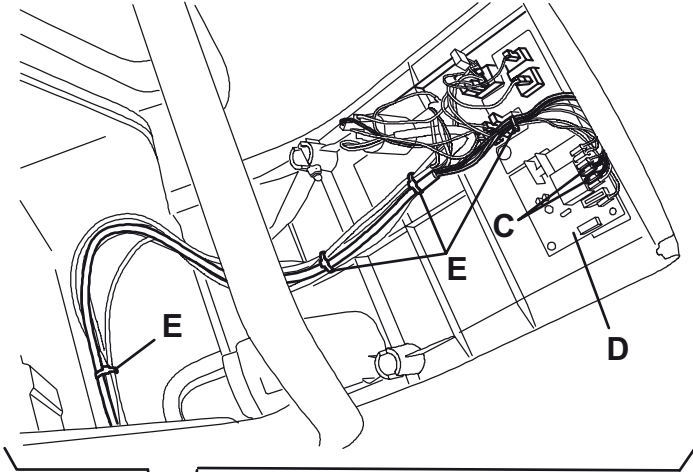

S301532

BRUSHING SYSTEM**BRUSH MOTOR ELECTRICAL INPUT CHECK (For BA 451, BA 451D, BA 531, BA 531D)****WARNING!**

This procedure must be performed by qualified personnel only.

Check

1. If the tank (21) contains recovery water:
 - Drive the machine to the appointed recovery water disposal area.
 - (For **BA 451D, BA 551D**) Turn the ignition key (80) to "0".
 - (For **BA 451, BA 551**) Turn off the switches (71) and (73).
 - Empty the recovery water tank (21) with the hose (16).
2. Drive the machine on a level floor.
3. Remove the brush/pad-holder.
4. Lower the deck by pressing the pedal (11).
5. - (For **BA 451D, BA 551D**) Turn the ignition key (80) to "0".
- (For **BA 451, BA 551**) Turn off the switches (71) and (73).
6. Grasp the handle (41) and carefully lift the tank (40).
7. (For machines with **EcoFlex™ system**)
 - Unscrew the union (A).
 - Remove the detergent tank (B).
 - Remove the screws (C).
 - Slightly lift the tank holder (D) and mark the position of the connectors (E) and (F) (to reinstall them correctly), which must be as follows:
 - Connector (E): white cable
 - Connector (F): blue cable
 - Disconnect the connectors (E) and (F) from the detergent pump (G).
 - Disconnect the hoses (H) from the union (I) and remove the tank holder (D) together with the detergent pump (G).
8. Apply the amperometric pliers (J) on one cable (K) of the brush motor (L).
9. (For **BA 451D, BA 551D**) Turn the speed adjuster (4) to idle and turn the ignition key (80) to "I".
10. Turn on the brush/pad-holder by pressing the switch (71) and check that the motor electrical input is 3 - 4 A at 24 V. Turn off the brush/pad-holder by pressing the switch (71).
(For **BA 451D, BA 551D**) Turn the ignition key (80) to "0".
Remove the amperometric pliers (J).

If the electrical input is higher, perform the following procedures to detect and correct the abnormal input:

**NOTE**

If the electrical input is higher than the maximum allowed value, the 3 battery warning leds (81) flash simultaneously.

- Check the tightening of F1 fuse screw (see the procedure in Fuse Check/Replacement paragraph).
- Check if there is dust or dirt (ropes, cables, etc.) on the brush/pad-holder hub.
- Check the motor carbon brushes (see the procedure in the relevant paragraph).
- Disassemble the motor (see the procedure in the relevant paragraph), and check the condition of all its components.

If the above-mentioned procedures do not lead to a correct electrical input, the motor must be replaced (see the procedure in the relevant paragraph).

Reset

11. Perform steps 3 to 7 in the reverse order.

BRUSHING SYSTEM

BRUSH MOTOR ELECTRICAL INPUT CHECK (For BA 451, BA 451D, BA 531, BA 531D) (Continues)

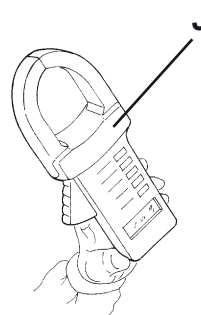
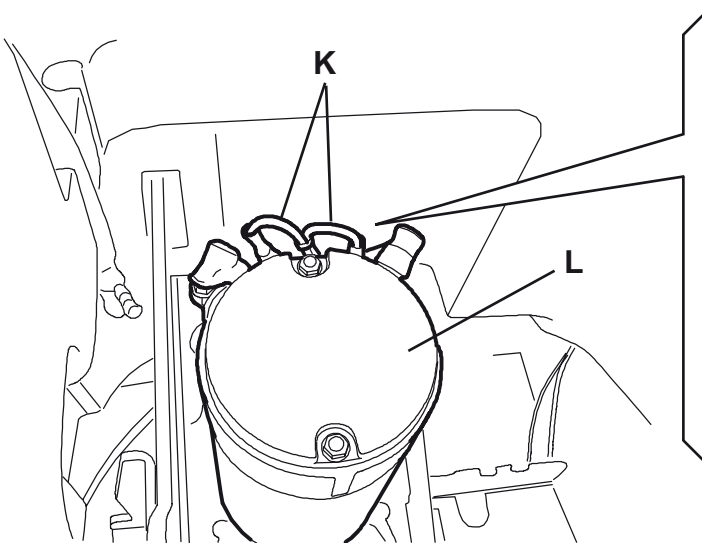
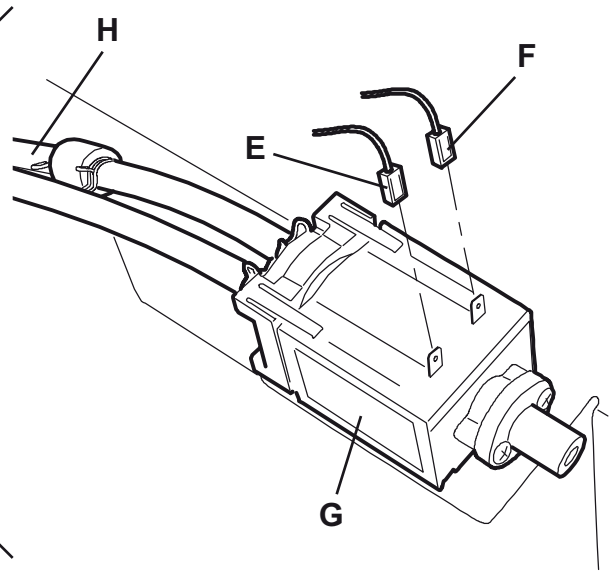
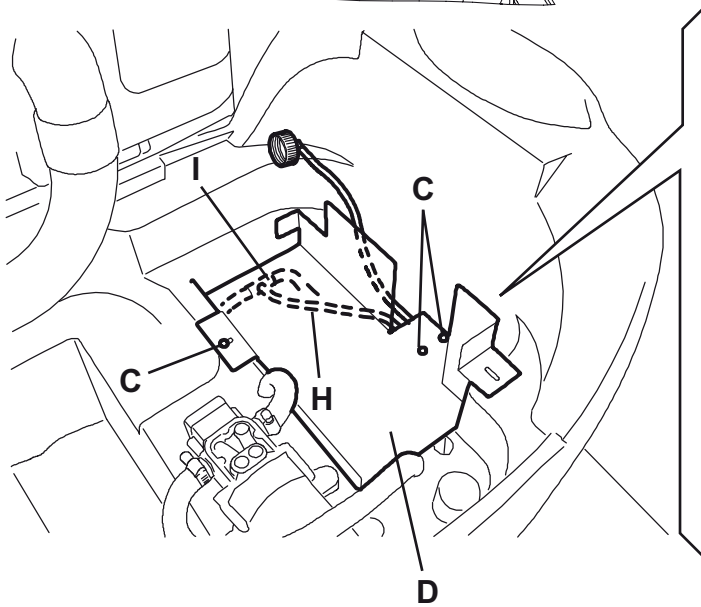
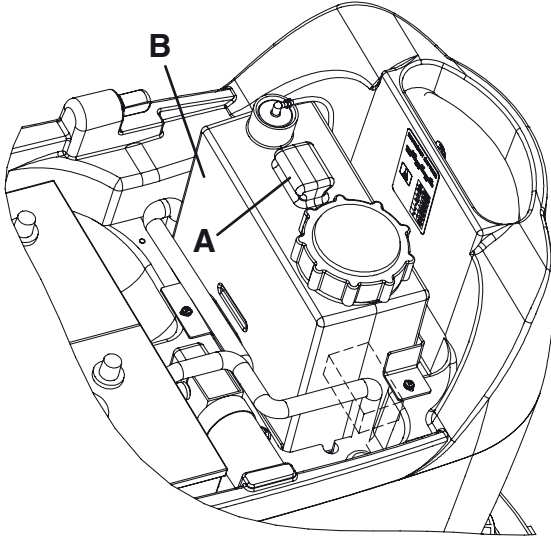

S301533

BRUSHING SYSTEM**BRUSH MOTOR ELECTRICAL INPUT CHECK (For BA 551, BA 551D)****WARNING!**

This procedure must be performed by qualified personnel only.

Check

1. If the tank (21) contains recovery water:
 - Drive the machine to the appointed recovery water disposal area.
 - (For **BA 551D**) Turn the ignition key (80) to "0".
 - (For **BA 551**) Turn off the switches (71) and (73).
 - Empty the recovery water tank (21) with the hose (16).
2. Drive the machine on a level floor.
3. Remove the brush/pad-holder.
4. Lower the deck by pressing the pedal (11).
5. - (For **BA 551D**) Turn the ignition key (80) to "0".
- (For **BA 551**) Turn off the switches (71) and (73).
6. Grasp the handle (41) and carefully lift the tank (40).
7. (For machines with **EcoFlex™ system**)
 - Unscrew the union (A).
 - Remove the detergent tank (B).
 - Remove the screws (C).
 - Slightly lift the tank holder (D) and mark the position of the connectors (E) and (F) (to reinstall them correctly), which must be as follows:
 - Connector (E): white cable
 - Connector (F): blue cable
 - Disconnect the connectors (E) and (F) from the detergent pump (G).
 - Disconnect the hoses (H) from the union (I) and remove the tank holder (D) together with the detergent pump (G).
8. Apply the amperometric pliers (J) on one cable (K) of the brush motor (L).
9. (For **BA 551D**) Turn the speed adjuster (4) to idle and turn the ignition key (80) to "I".
10. Turn on the brush/pad-holder by pressing the switch (71) and check that the motor electrical input is 3 - 4 A at 24 V. Turn off the brush/pad-holder by pressing the switch (71).
(For **BA 551D**) Turn the ignition key (80) to "0".
Remove the amperometric pliers (J).

If the electrical input is higher, perform the following procedures to detect and correct the abnormal input:

**NOTE**

If the electrical input is higher than the maximum allowed value, the 3 battery warning leds (81) flash simultaneously.

- Check the tightening of F1 fuse screw (see the procedure in Fuse Check/Replacement paragraph).
- Check if there is dust or dirt (ropes, cables, etc.) on the brush/pad-holder hub.
- Check the motor carbon brushes (see the procedure in the relevant paragraph).
- Disassemble the motor (see the procedure in the relevant paragraph), and check the condition of all its components.

If the above-mentioned procedures do not lead to a correct electrical input, the motor must be replaced (see the procedure in the relevant paragraph).

Reset

11. Perform steps 3 to 7 in the reverse order.

BRUSHING SYSTEM

BRUSH MOTOR ELECTRICAL INPUT CHECK (For BA 551, BA 551D) (Continues)

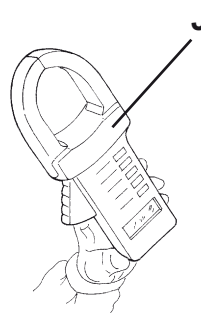
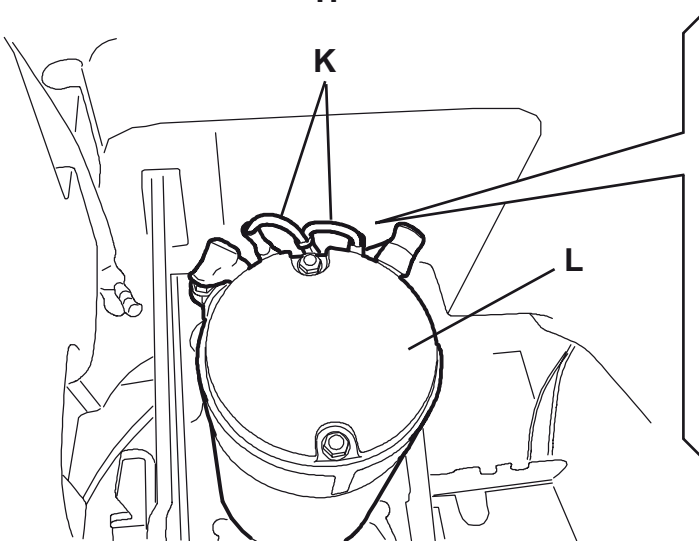
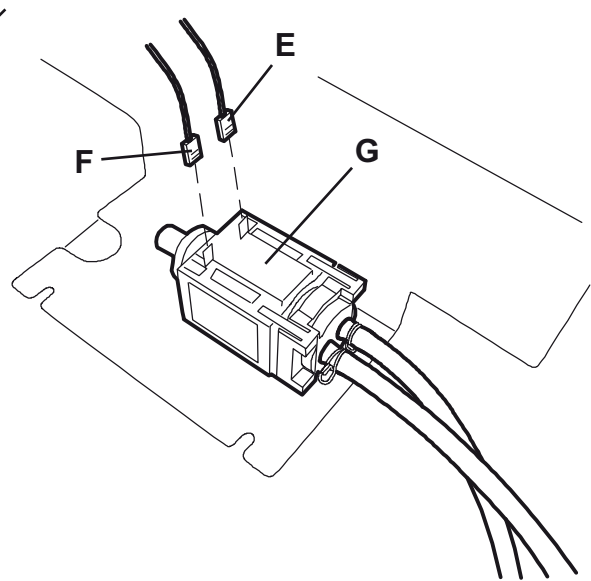
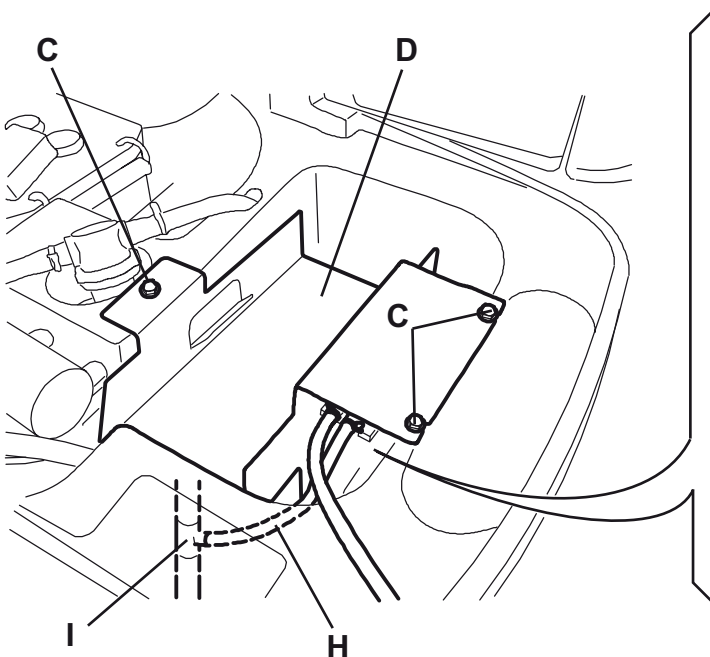
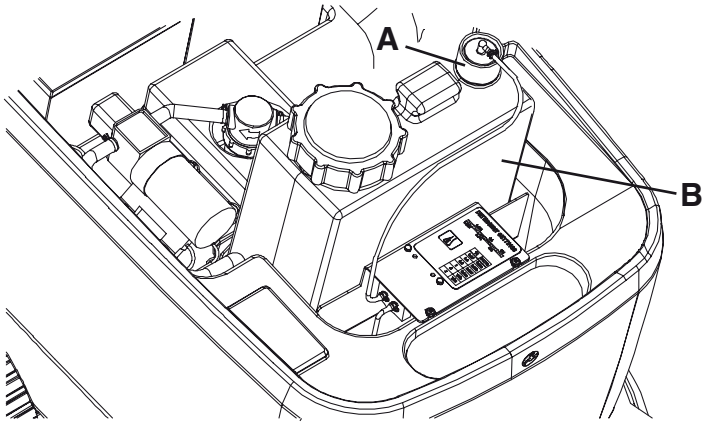

S301534

BRUSHING SYSTEM

BRUSH MOTOR ELECTRICAL INPUT CHECK (For BA 551CD)

**WARNING!**

This procedure must be performed by qualified personnel only.

Check

1. Remove the cylindrical brushes, as shown in the User Manual.
 2. Lower the deck by pressing the pedal (11).
 3. Apply the amperometric pliers (A) on one cable (B) of the brush motor (C).
 4. Turn the speed adjuster (4) to idle and turn the ignition key (80) to "I".
 5. Turn on the brushes by pressing the switch (71) and check that the motor electrical input is 5 - 8 A at 24 V. Turn off the brushes by pressing the switch (71). Turn the ignition key (80) to "0". Remove the amperometric pliers (A).
- If the electrical input is higher, perform the following procedures to detect and correct the abnormal input:

**NOTE**

If the electrical input is higher than the maximum allowed value, the 3 battery warning leds (81) flash simultaneously.

- Check the tightening of F1 fuse screw (see the procedure in Fuse Check/Replacement paragraph).
- Check if there is dust or dirt (ropes, cables, etc.) on the brush hub.
- Check the motor carbon brushes (see the procedure in the relevant paragraph).
- Disassemble the motor (see the procedure in the relevant paragraph), and check the condition of all its components.

If the above-mentioned procedures do not lead to a correct electrical input, the motor must be replaced (see the procedure in the relevant paragraph).

Reset

6. Perform steps 1 and 2 in the reverse order.

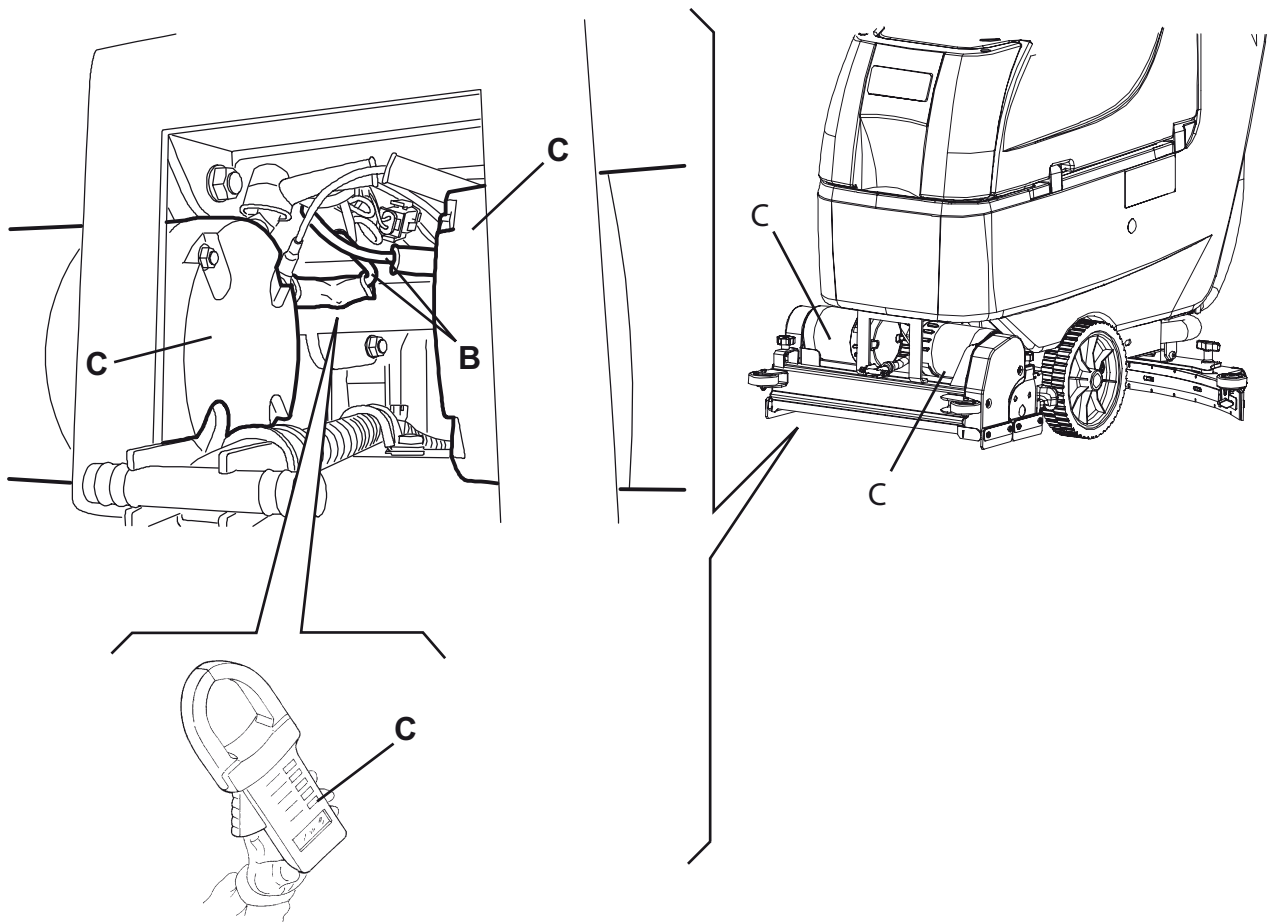

S301535

BRUSHING SYSTEM

BRUSH MOTOR ELECTRICAL INPUT CHECK (For BA 611D)

WARNING!

This procedure must be performed by qualified personnel only.

Check

1. Remove the brushes, as shown in the User Manual.
 2. Lower the deck by pressing the pedal (11).
 3. Apply the amperometric pliers (A) on one cable (B) of the brush motor (C).
 4. Turn the speed adjuster (4) to idle and turn the ignition key (80) to "I".
 5. Turn on the brushes by pressing the switch (71) and check that the motor electrical input is 5 - 7 A at 24 V. Turn off the brushes by pressing the switch (71).
Turn the ignition key (80) to "0".
Remove the amperometric pliers (A).
- If the electrical input is higher, perform the following procedures to detect and correct the abnormal input:

NOTE

If the electrical input is higher than the maximum allowed value, the 3 battery warning leds (81) flash simultaneously.

- Check the tightening of F1 fuse screw (see the procedure in Fuse Check/Replacement paragraph).
- Check if there is dust or dirt (ropes, cables, etc.) on the brush hub.
- Check the motor carbon brushes (see the procedure in the relevant paragraph).
- Disassemble the motor (see the procedure in the relevant paragraph), and check the condition of all its components.

If the above-mentioned procedures do not lead to a correct electrical input, the motor must be replaced (see the procedure in the relevant paragraph).

Reset

6. Perform steps 1 and 2 in the reverse order.

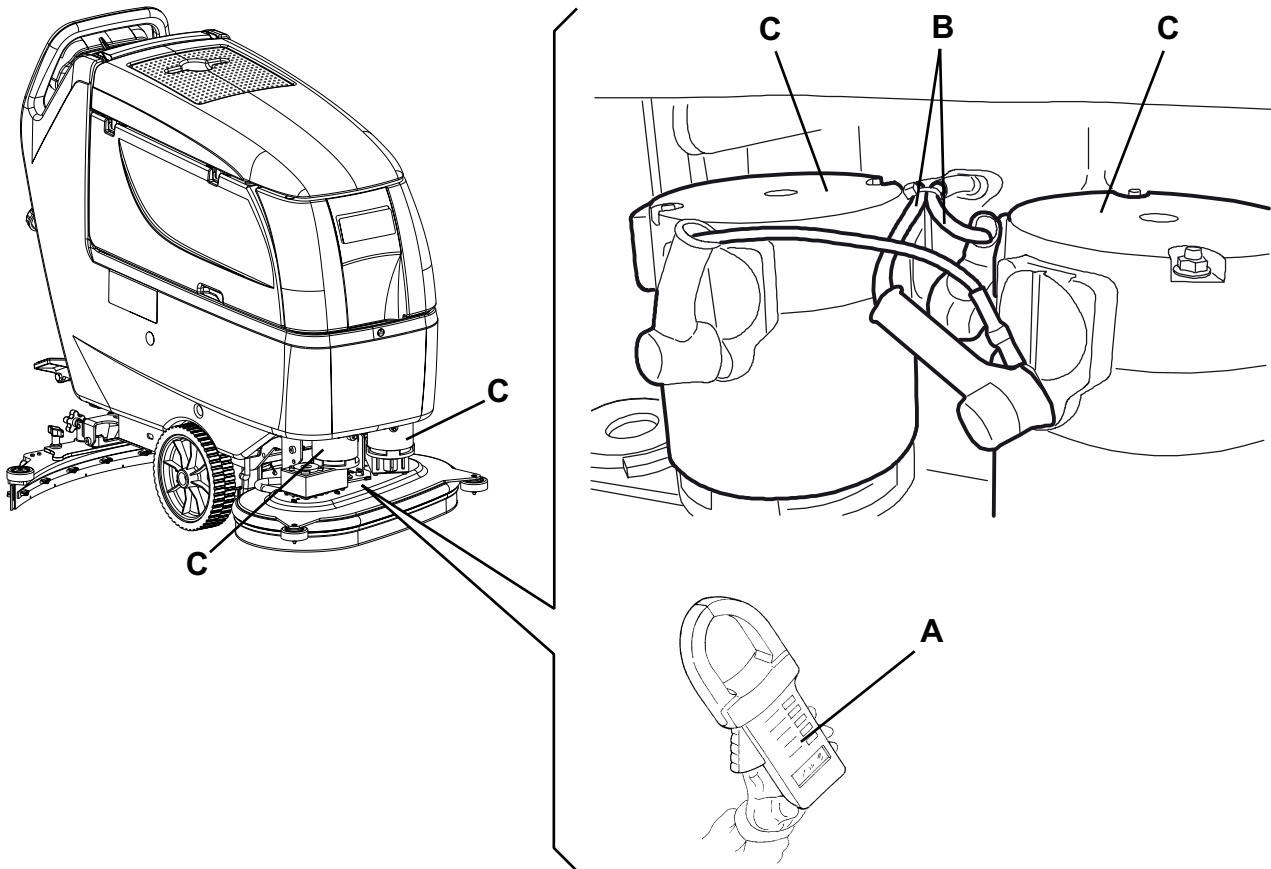

S301536

BRUSHING SYSTEM**BRUSH MOTOR ELECTRICAL INPUT CHECK (For CA 451, CA 531, CA 551)****WARNING!**

This procedure must be performed by qualified personnel only.

Check

1. Remove the brush, as shown in the User Manual.
2. Disconnect the power supply cable (59) from the electrical mains but do not place it on the holder (60).
3. If the power supply cable (59) is on the holder (60), remove it.
4. Move aside the recovery water drain hose (16).
5. Remove the mounting screws (A) of the panel (C).
6. Loosen the mounting screws (B) of the panel (C).
7. Carefully move backwards the upper end (D) of the panel (C).
8. Apply the amperometric pliers (E) on one cable (F) (connection symbols: "F4" or "F5") of the brush motor.
9. Connect the power supply cable (59) to the electrical mains.
10. Turn on the brush by pressing the switch (62) and check that the motor electrical input is 3 - 4 A at 230 V. Turn off the brush by pressing the switch (62).

Disconnect the power supply cable (59) from the electrical mains.

Remove the amperometric pliers (E).

If the electrical input is higher, perform the following procedures to detect and correct the abnormal input:

- Check if there is dust or dirt (ropes, cables, etc.) on the brush hub.
- Check the motor carbon brushes (see the procedure in the relevant paragraph).

If the above-mentioned procedures do not lead to a correct electrical input, the motor must be replaced (see the procedure in the relevant paragraph).

Reset

11. Perform steps 3 to 7 in the reverse order.

BRUSHING SYSTEM

BRUSH MOTOR ELECTRICAL INPUT CHECK (For CA 451, CA 531, CA 551) (Continues)

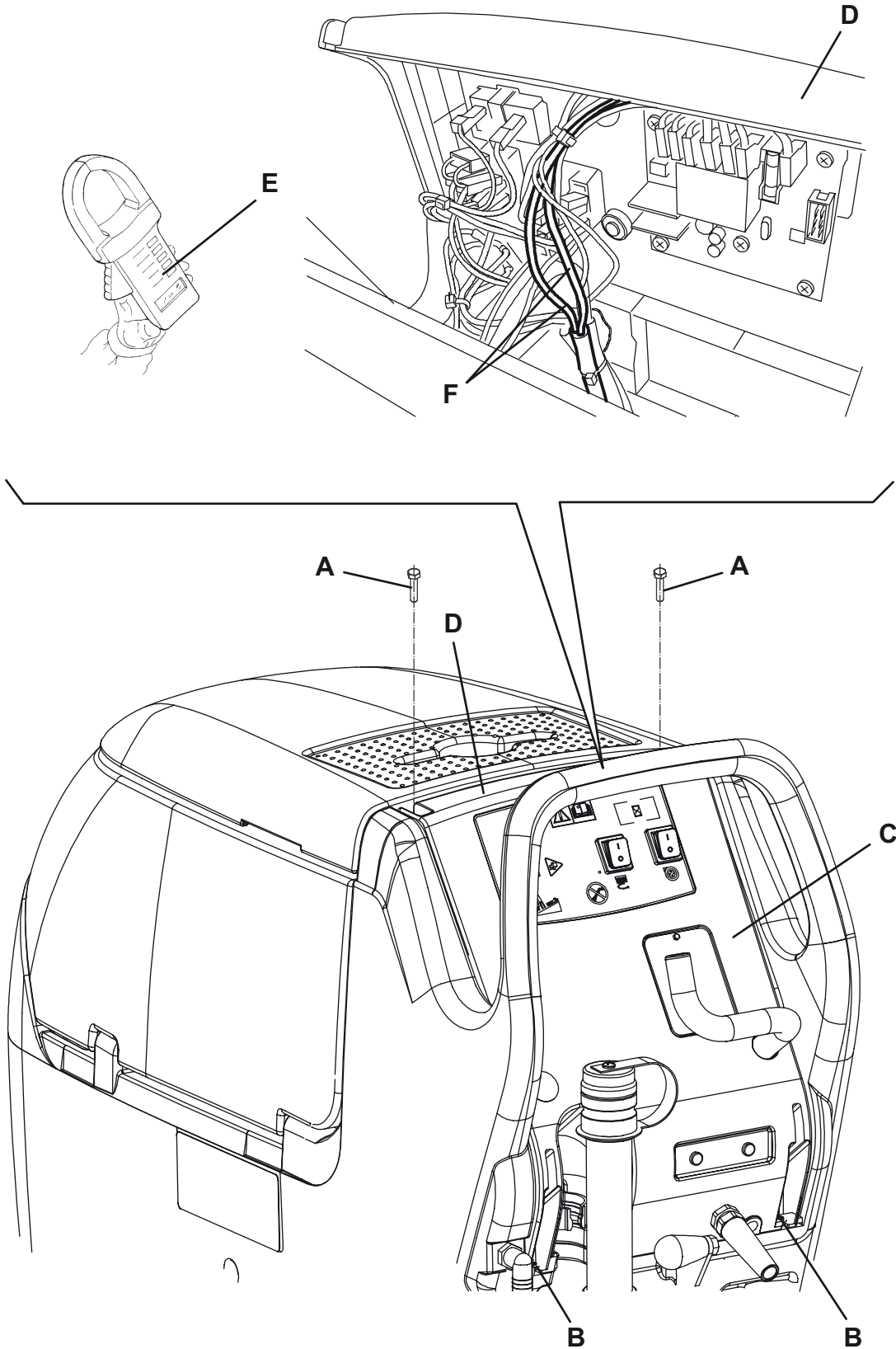

S301537

BRUSHING SYSTEM**BRUSH MOTOR CARBON BRUSH CHECK/REPLACEMENT(For BA 451, BA 451D, BA 531, BA 531D)****Check**

1. If the tank (21) contains recovery water:
 - Drive the machine to the appointed recovery water disposal area.
 - (For **BA 451D, BA 531D**) Turn the ignition key (80) to "0".
 - (For **BA 451, BA 531**) Turn off the switches (71) and (73).
 - Empty the recovery water tank (21) with the hose (16).
2. Drive the machine on a level floor.
3. Remove the brush/pad-holder.
4. Lower the deck by pressing the pedal (11).
5. (For **BA 451D, BA 531D**) Turn the ignition key (80) to "0".
(For **BA 451, BA 531**) Turn off the switches (71) and (73).
6. Grasp the handle (41) and carefully lift the tank (40).
7. (For machines with **EcoFlex™ system**)
 - Unscrew the union (A).
 - Remove the detergent tank (B).
 - Remove the screws (C).
 - Slightly lift the tank holder (D) and mark the position of the connectors (E) and (F) (to reinstall them correctly), which must be as follows:
 - Connector (E): white cable
 - Connector (F): blue cable
 - Disconnect the connectors (E) and (F) from the detergent pump (G).
 - Disconnect the hoses (H) from the union (I) and remove the tank holder (D) together with the detergent pump (G).
8. Disconnect the battery connector (12).
9. Remove dust and dirt from the motor carbon brush support area (A).
10. Disengage the fasteners (K) and (L) and remove four carbon brush supports (J). If necessary, disconnect the electrical connections (M).
11. Check if the carbon brushes (N) are worn. Replace the carbon brushes when: the contact with the motor armature is insufficient, the carbon brushes are worn, the carbon brush contact surface is not integral, the thrust spring is broken, etc.
12. If necessary, disconnect the connections (F) and remove the carbon brushes with their supports (A) to replace them. Replace the carbon brushes as an assembly.

Reset

13. Assemble the components in the reverse order of disassembly, and note the following:
 - When connecting the terminals (O), take care of their insulation from the surrounding parts of the frame.

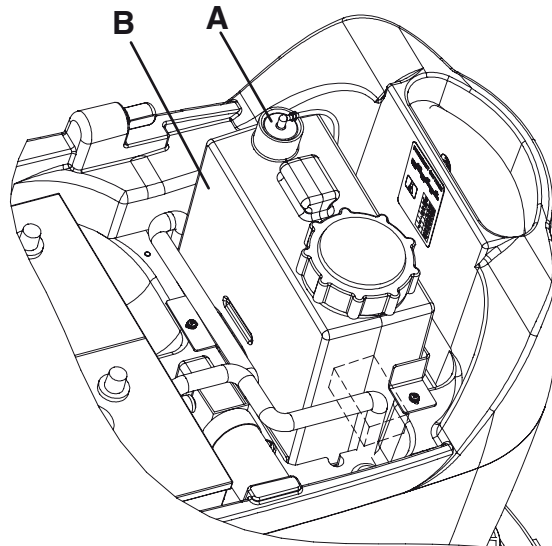

S301538

BRUSHING SYSTEM

BRUSH MOTOR CARBON BRUSH CHECK/REPLACEMENT(For BA 451, BA 451D, BA 531, BA 531D) (Continues)

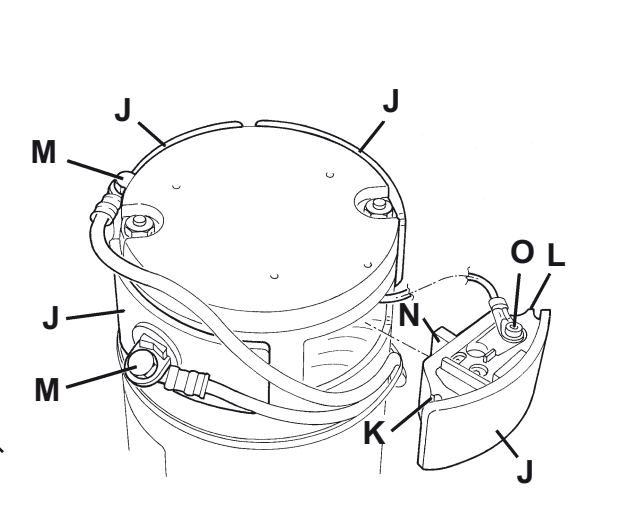
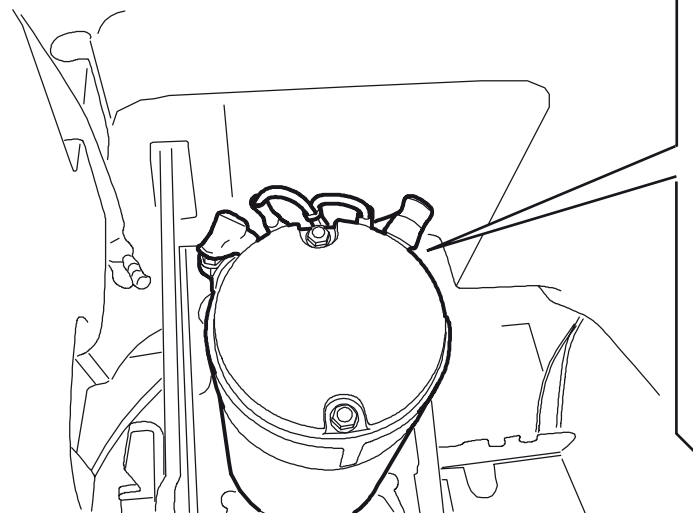
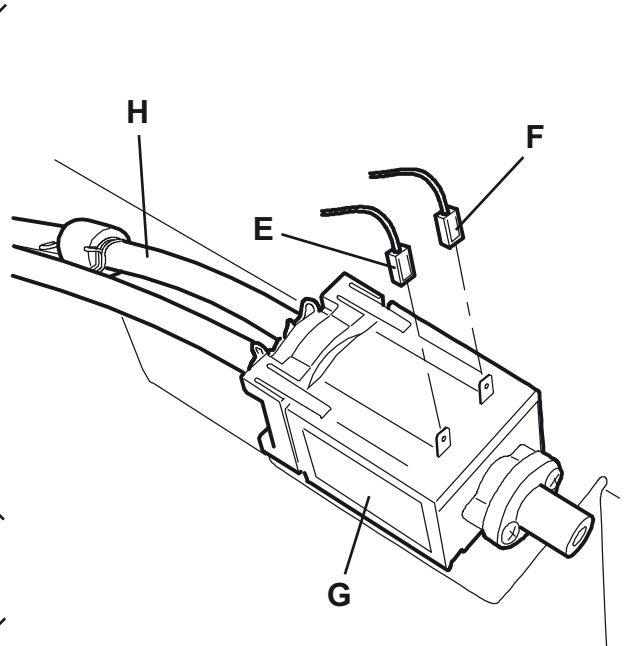
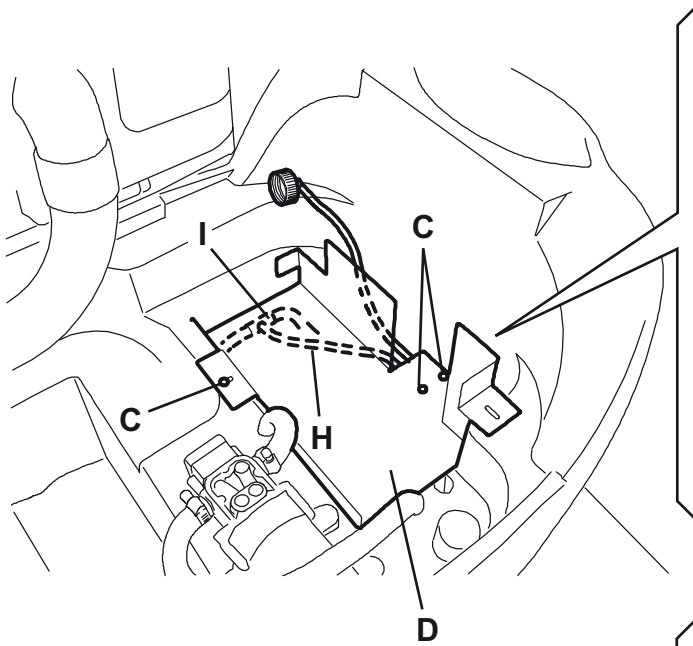

S301539

BRUSHING SYSTEM**BRUSH MOTOR CARBON BRUSH CHECK/REPLACEMENT (For BA 551, BA 551D)****Check**

1. If the tank (21) contains recovery water:
 - Drive the machine to the appointed recovery water disposal area.
 - (For **BA 551D**) Turn the ignition key (80) to "0".
 - (For **BA 551**) Turn off the switches (71) and (73).
 - Empty the recovery water tank (21) with the hose (16).
2. Drive the machine on a level floor.
3. Remove the brush/pad-holder.
4. Lower the deck by pressing the pedal (11).
5. (For **BA 551D**) Turn the ignition key (80) to "0".
(For **BA 551**) Turn off the switches (71) and (73).
6. Grasp the handle (41) and carefully lift the tank (40).
7. (For machines with **EcoFlex™ system**)
 - Unscrew the union (A).
 - Remove the detergent tank (B).
 - Remove the screws (C).
 - Slightly lift the tank holder (D) and mark the position of the connectors (E) and (F) (to reinstall them correctly), which must be as follows:
 - Connector (E): white cable
 - Connector (F): blue cable
 - Disconnect the connectors (E) and (F) from the detergent pump (G).
 - Disconnect the hoses (H) from the union (I) and remove the tank holder (D) together with the detergent pump (G).
8. Disconnect the battery connector (12).
9. Remove dust and dirt from the motor carbon brush support area (A).
10. Disengage the fasteners (K) and (L) and remove four carbon brush supports (J). If necessary, disconnect the electrical connections (M).
11. Check if the carbon brushes (N) are worn. Replace the carbon brushes when: the contact with the motor armature is insufficient, the carbon brushes are worn, the carbon brush contact surface is not integral, the thrust spring is broken, etc.
12. If necessary, disconnect the connections (O) and remove the carbon brushes with their supports (J) to replace them. Replace the carbon brushes as an assembly.

Reset

13. Assemble the components in the reverse order of disassembly, and note the following:
 - When connecting the terminals (O), take care of their insulation from the surrounding parts of the frame.

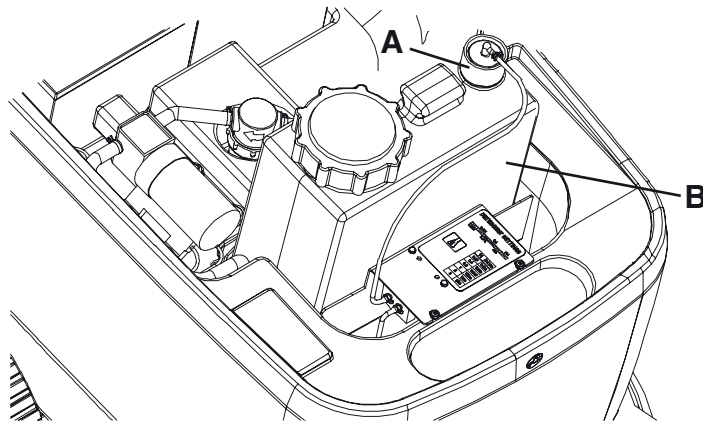

S301540

BRUSHING SYSTEM

BRUSH MOTOR CARBON BRUSH CHECK/REPLACEMENT (For BA 551, BA 551D) (Continues)

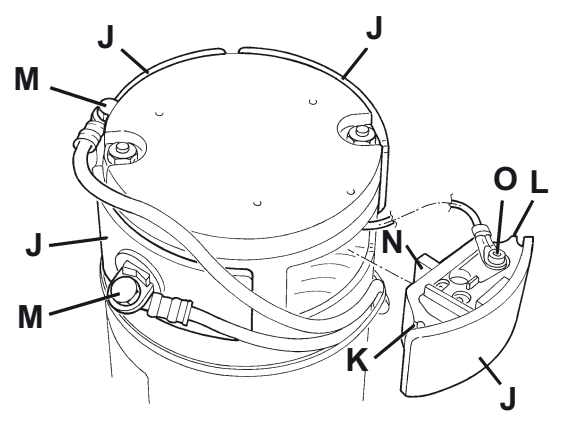
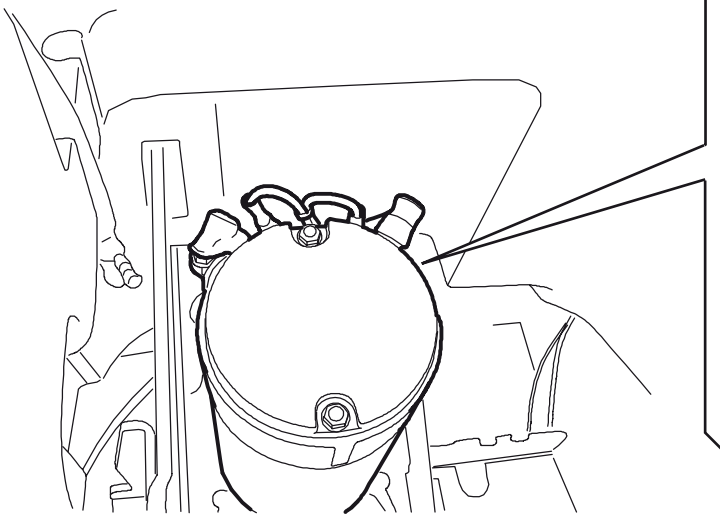
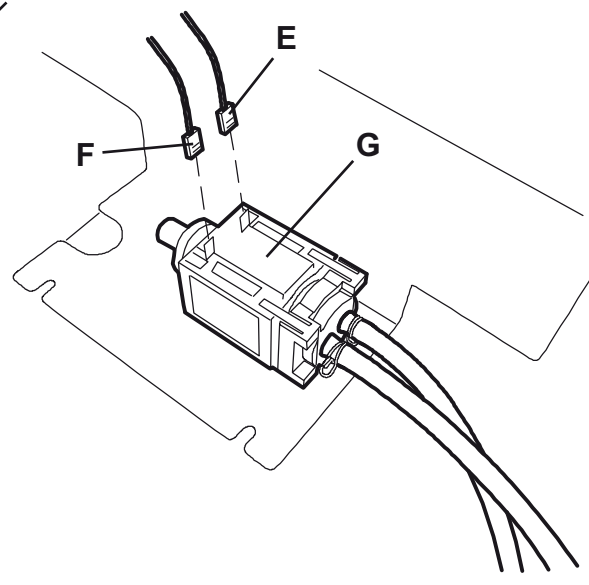
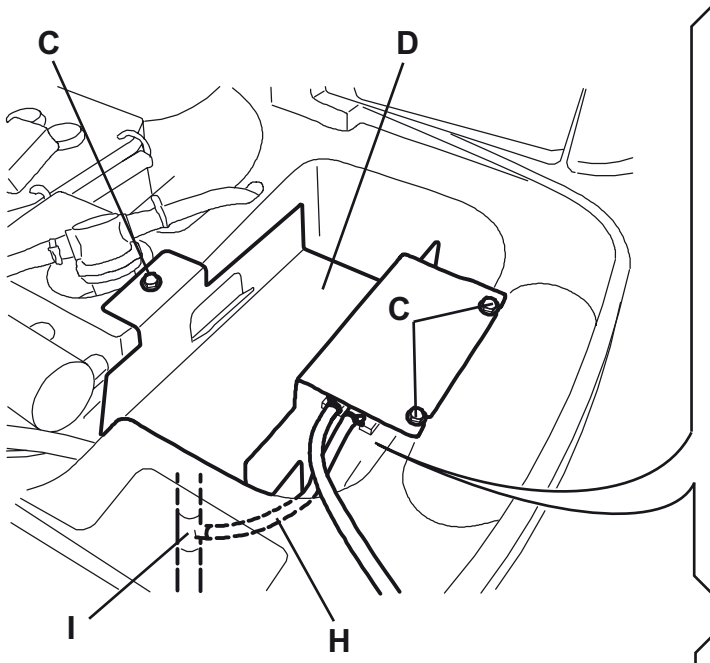

S301541

BRUSHING SYSTEM**BRUSH MOTOR CARBON BRUSH CHECK/REPLACEMENT (For BA 551CD)****Check**

1. Remove the brush motor (see the procedure in the relevant paragraph).
2. At the workbench, remove dust and debris from the motor, especially in the area of the protection clamp (A).
3. Remove the protection clamp (A).
4. For each carbon brush, move the protection (B) and remove the screws (C).
5. Remove the carbon brushes (D).
6. Check if the carbon brushes (D) are worn. Replace the carbon brushes when: the contact with the motor armature is insufficient, the carbon brushes are worn, the carbon brush contact surface is not integral, the thrust spring is broken, etc. Replace the carbon brushes as an assembly.

Reset

7. Assemble the components in the reverse order of disassembly.

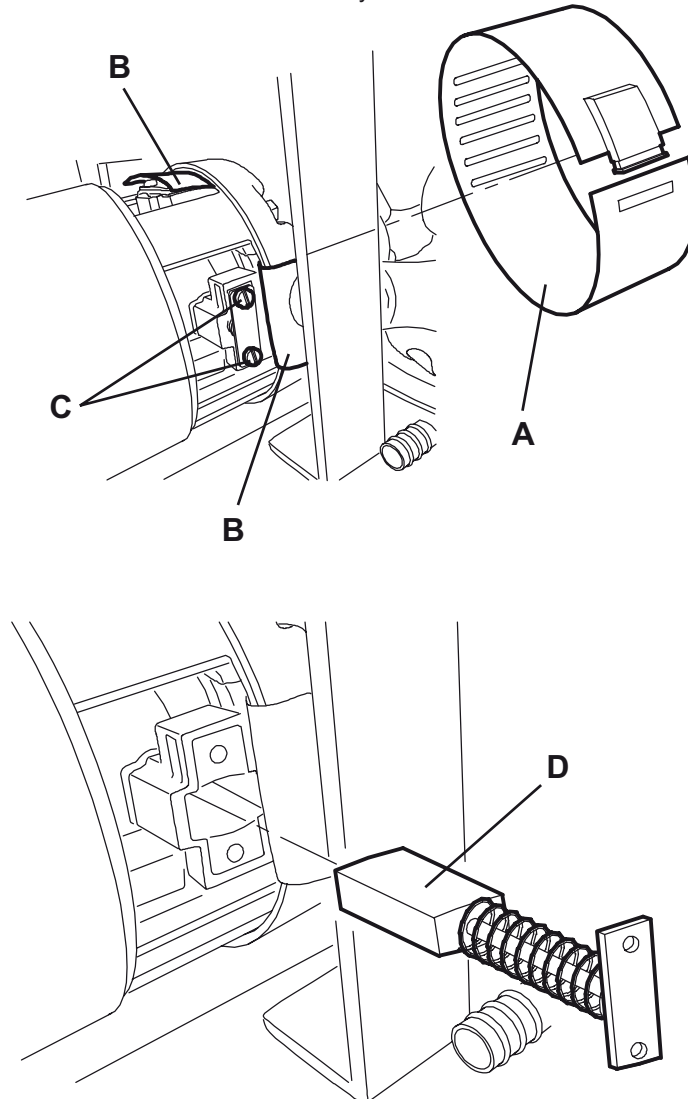

S301542

BRUSHING SYSTEM

BRUSH MOTOR CARBON BRUSH CHECK/REPLACEMENT (For BA 611D)

Check

1. Remove the deck (see the procedure in the relevant paragraph).
2. At the workbench, remove dust and debris from the motor, especially in the area of the carbon brushes.
3. Remove four protection covers (A) by disengaging the fasteners.
4. Remove the carbon brush nuts (B) with the lead-in wires.
5. Disengage the tabs (C) and remove the carbon brushes (D).
6. Check if the carbon brushes (D) are worn. Replace the carbon brushes when: the contact with the motor armature is insufficient, the carbon brushes are worn, the carbon brush contact surface is not integral, the thrust spring is broken, etc. Replace the carbon brushes as an assembly.

Reset

7. Assemble the components in the reverse order of disassembly.

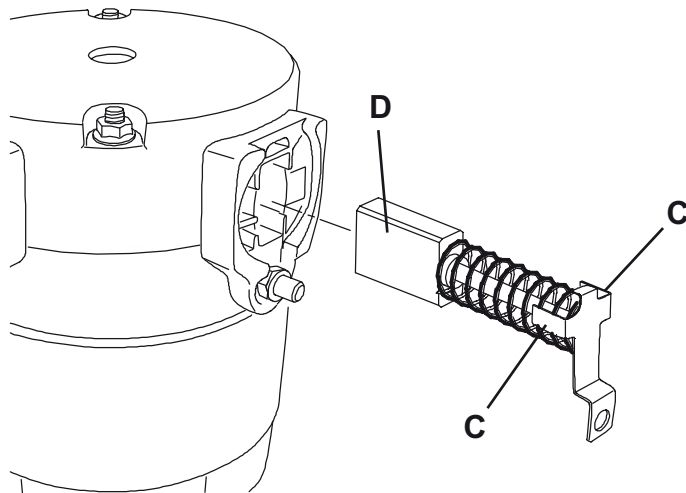
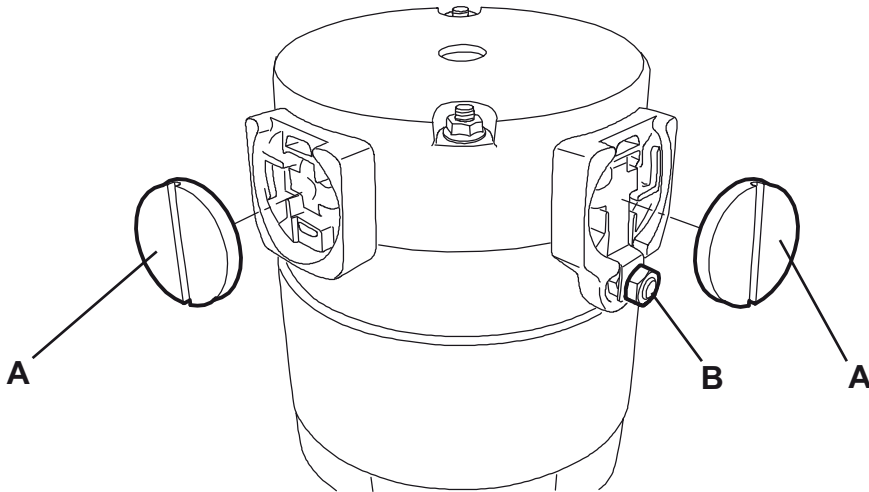

S301543

BRUSHING SYSTEM**BRUSH MOTOR DISASSEMBLY/ASSEMBLY (For BA 451, BA 451D, BA 531, BA 531D, BA 551, BA 551D)****Disassembly**

1. Remove the deck (see the procedure in the relevant paragraph).
2. At the workbench, remove the screw (A) from the deck.
3. Remove the hub assembly (B) with a puller.
4. Remove the screws (C).
5. Remove the reduction unit (D).
6. If necessary, remove the water distribution union (E) and flange (F) from the reduction unit.

Assembly

7. Assemble the components in the reverse order of disassembly.

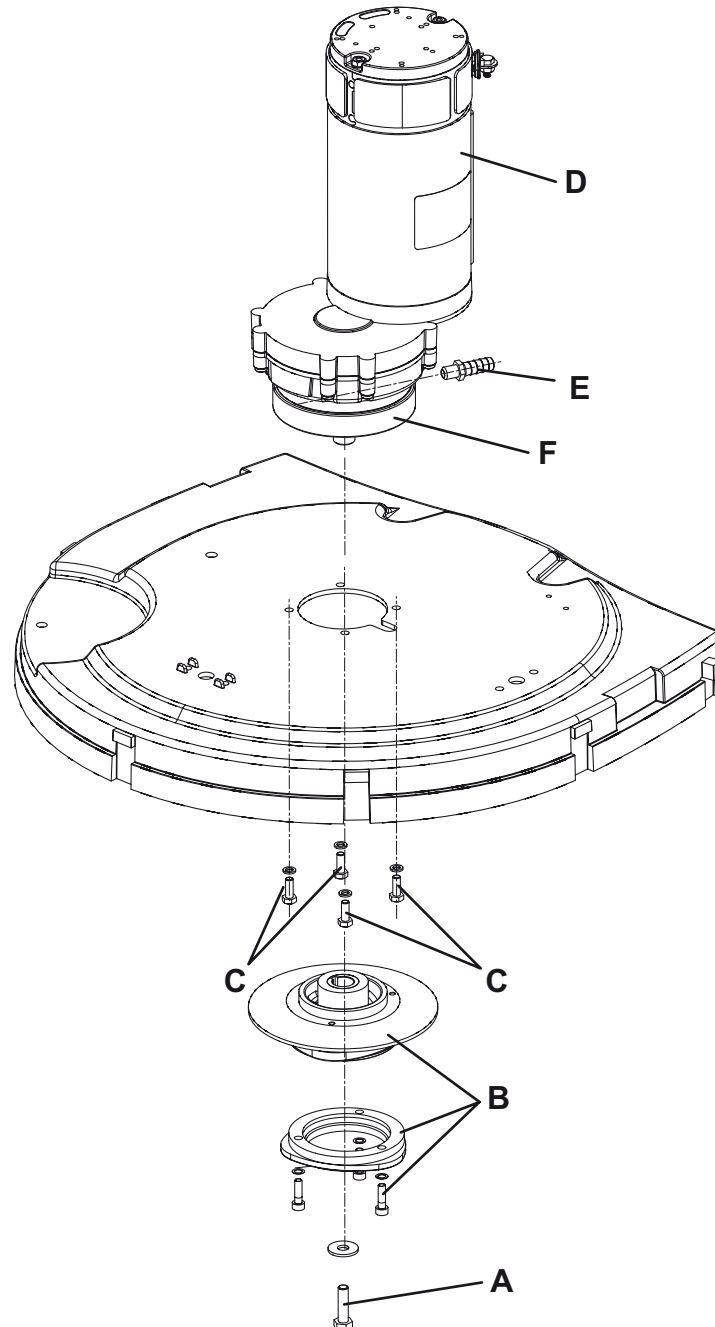

S301544

BRUSHING SYSTEM

BRUSH MOTOR DISASSEMBLY/ASSEMBLY (For BA 551CD)

Disassembly

1. Remove the cylindrical brush deck (see the procedure in the relevant paragraph).
2. At the workbench, remove the screw (A) from the motor which has to be disassembled.
3. Remove the case (B).
4. Loosen the nut (C) and move the pulley (D) to loosen the belt (E).
5. Remove the belt (E).
6. Remove the screws (F).
7. Remove the motor (G).

Assembly

8. Assemble the components in the reverse order of disassembly, and note the following:
 - The electrical connections (H) of the motor (G) must be turned upwards.
 - The connection (J) of the carbon brush protection clamps (I) must be positioned as shown in the figure.
 - Install the belt (E) and tension it properly (see the procedure in the relevant paragraph).

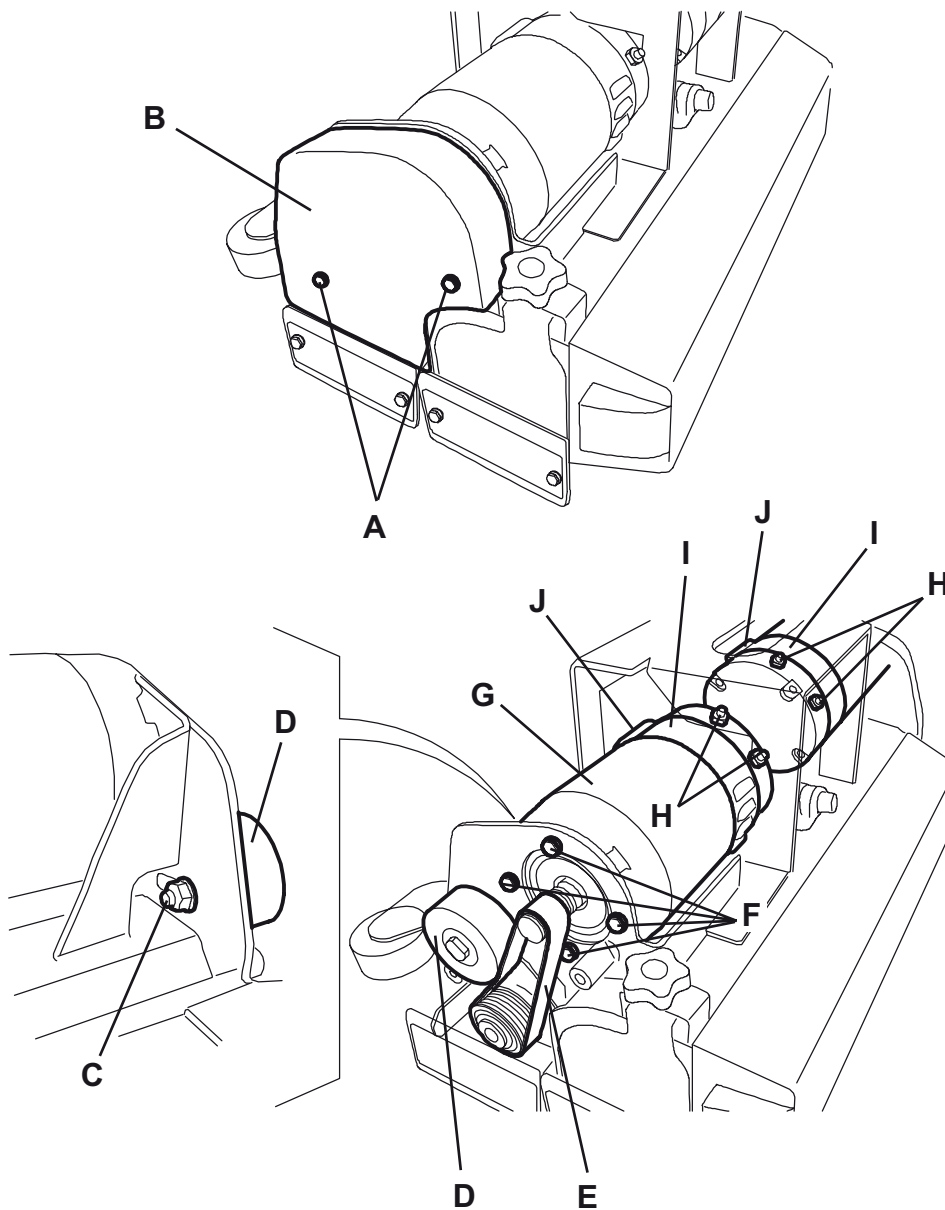

S301545

BRUSH MOTOR DISASSEMBLY/ASSEMBLY (For BA 611D)**Disassembly**

1. Remove the deck (see the procedure in the relevant paragraph).
2. At the workbench, remove the screw (A) from the reduction unit which has to be disassembled.
3. Remove the hub assembly (B) with a puller.
4. Remove the screws (C).
5. Remove the reduction unit (D).
6. Recover the key (E).

Assembly

7. Assemble the components in the reverse order of disassembly.

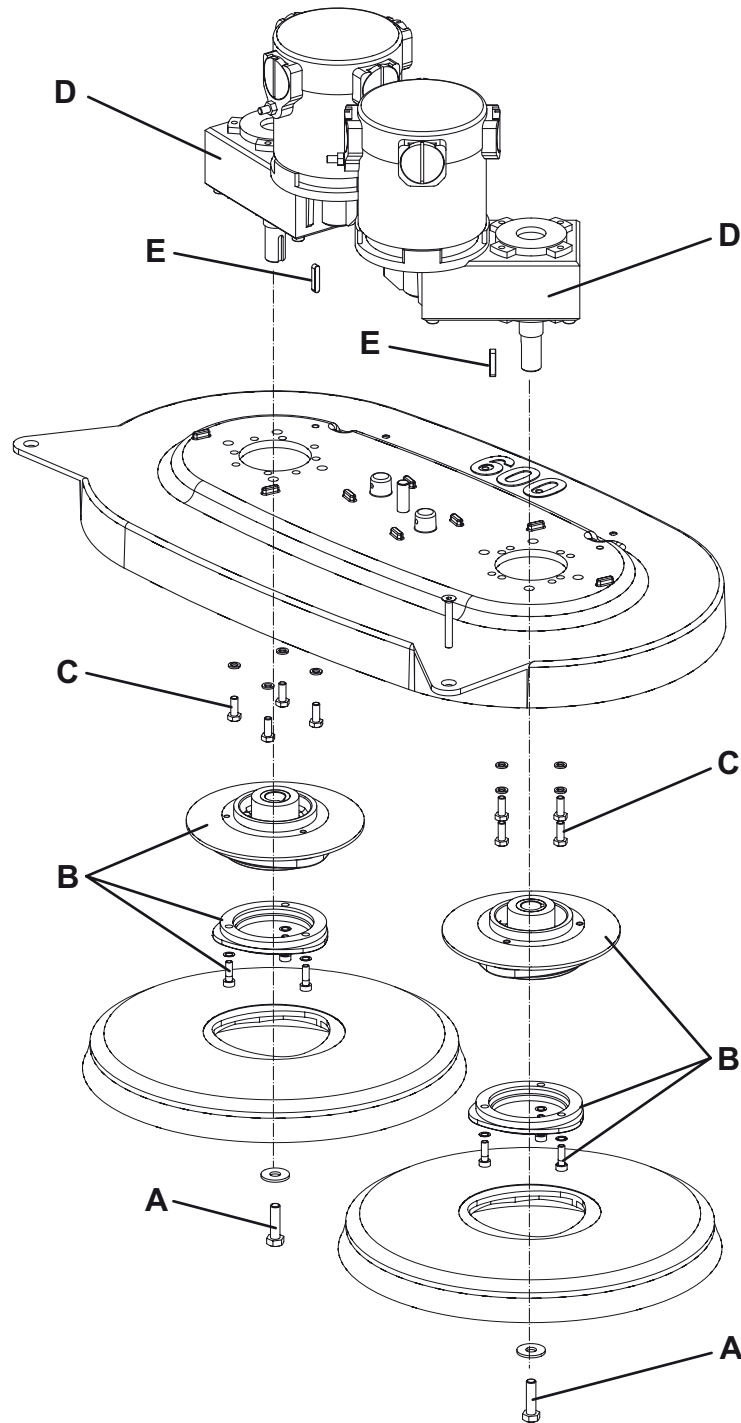

S301546-

BRUSHING SYSTEM

BRUSH MOTOR DISASSEMBLY/ASSEMBLY (For CA 451, CA 531, CA 551)

Disassembly

1. Remove the deck (see the procedure in the relevant paragraph).
2. At the workbench, remove the screw (A).
3. Remove the hub assembly (B) with a puller.
4. Remove the screws (C).
5. Remove the reduction unit (D) with the relevant wiring harness.
6. Recover the key (E).
7. If necessary, remove the solution hose (E).
8. If necessary, remove the motor wiring harness (G).

Assembly

1. Assemble the components in the reverse order of disassembly.



NOTE:

Figure showing CA 551

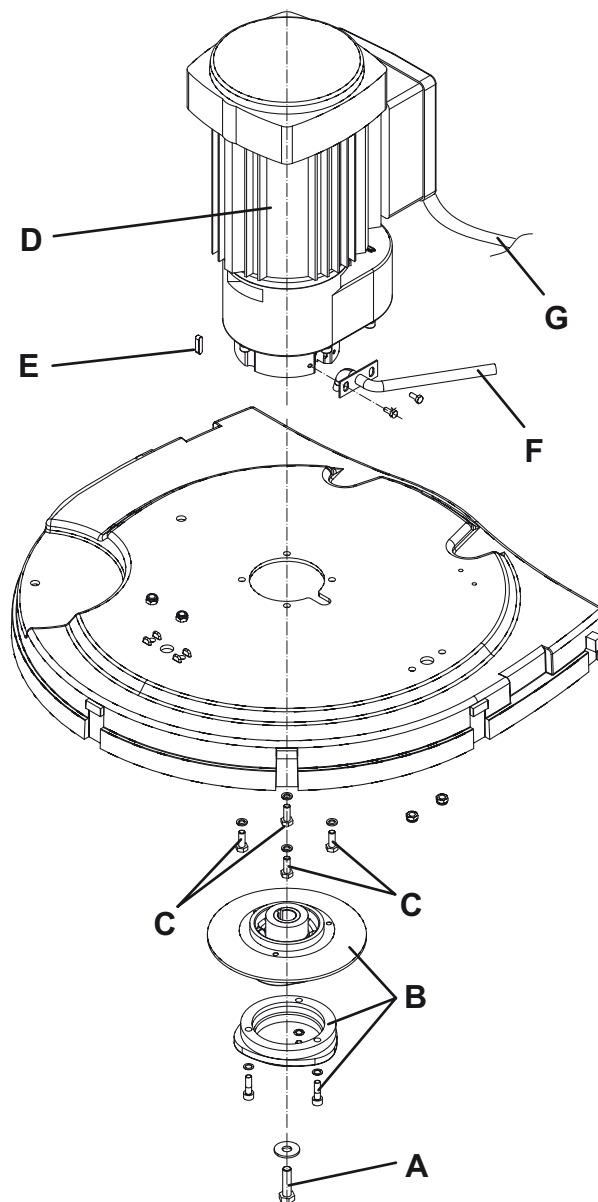

S301547

BRUSHING SYSTEM**CHECK/REPLACEMENT/ADJUSTMENT OF DRIVING BELTS FROM MOTORS TO CYLINDRICAL BRUSHES (For BA 551CD)****Check**

1. Drive the machine on a level floor.
2. Turn the ignition key (12) to "0".
3. Lower the cylindrical brush deck by pressing the pedal (11).
4. Remove the screws (A) and remove the covers (B).
5. Visually inspect the belt (C) for integrity, cuts, tears or cracks, otherwise replace it according to the following procedure.
6. Check the tension of the belt (G) according to the following procedure.

Replacement

7. If the belt (G) is to be replaced, loosen the nut (D) and move the pulley (K) to loosen the belt.
8. Tension the belt (according to the following procedure).

Belt tensioning

9. Check the tension of the belt (C) from motor to brush. The tension is correct:
 - When pressing the belt in its center with a force of 22 lb (10 kg) (F), the belt bends for 0.20 in (5 mm).If necessary, tension the belt according to the following procedure:
10. Loosen the nut (D) and adjust the position of the pulley (E). When tensioning procedure has been carried out, tighten the nut (D).
11. Repeat step 8.

Reset

12. Perform steps 3 and 4 in the reverse order.

BRUSHING SYSTEM

CHECK/REPLACEMENT/ADJUSTMENT OF DRIVING BELTS FROM MOTORS TO CYLINDRICAL BRUSHES (For BA 551CD) (Continues)

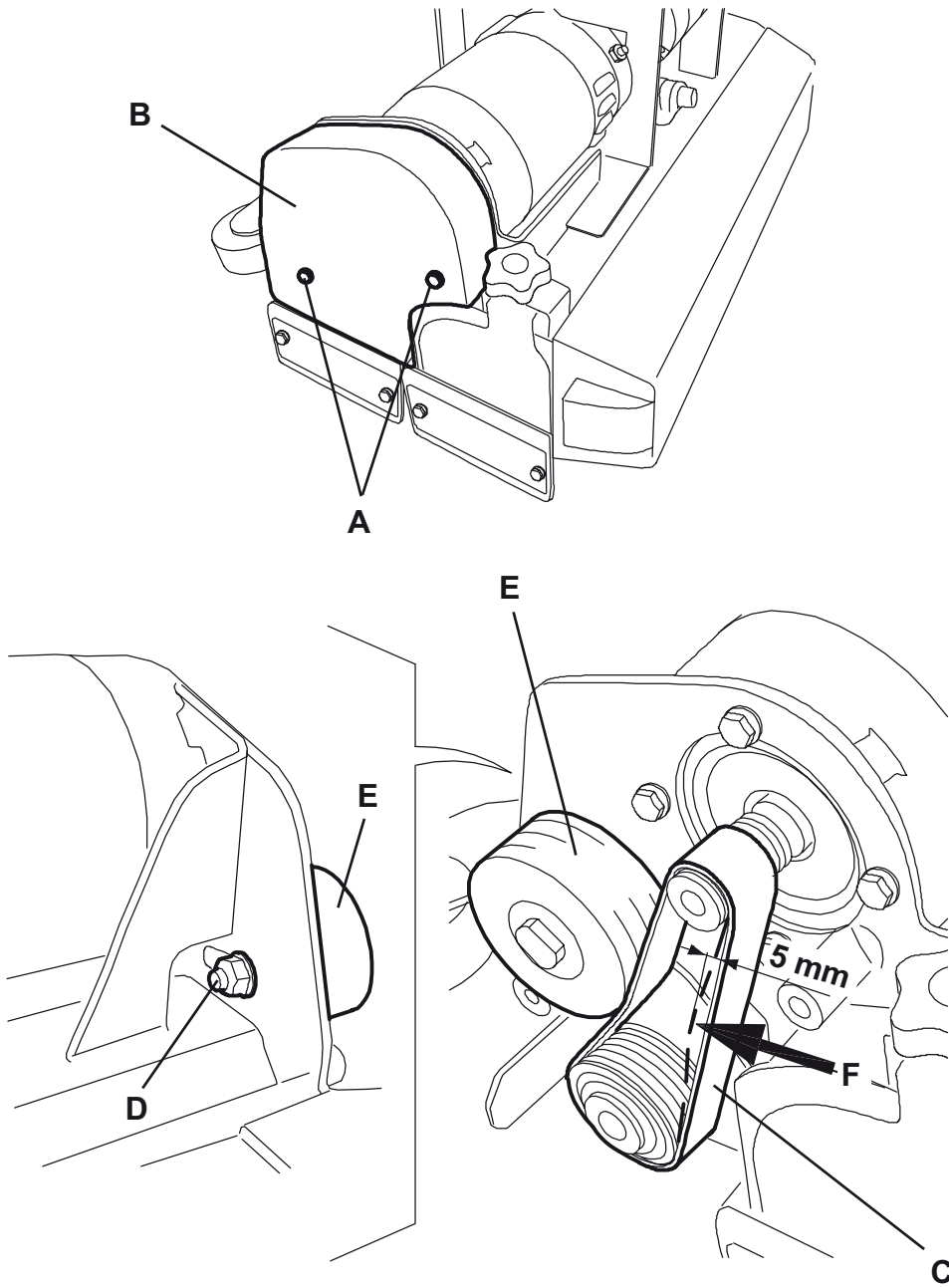

S301548

BRUSHING SYSTEM**BRUSH ENABLING MICROSWITCH ADJUSTMENT/REPLACEMENT (For BA 451D, BA 531D, BA 551D, BA 551CD, BA 611D)**

1. Drive the machine on a level floor.
2. Turn the ignition key (80) to "0".
3. Disconnect the battery connector (12).
4. Remove the screws (A) and move the drive paddle cover (B).
5. Check that the springs (C) operate correctly when releasing the drive paddle (D).
6. If necessary, replace the microswitch (F) according to the following procedure:
 - Mark the position of the connectors (I) and disconnect them from the microswitch.
 - Remove the screws (M).
 - Remove the microswitch (F).
 - Install the new microswitch and fasten it with the screws, then connect the connectors (I).
7. Check that the actuator (E) of the microswitch (F) is in the housing (G) of the cam (H) when the drive paddle is released (D). Check also that the cable contacts (I) are all opened (use a tester).
8. Press the drive paddle (D) and check that the actuator (E), in the positions (J) and (K) activates the microswitch (F) (a clicking sound must be heard). Check also that the cable contacts (I) are all closed (use a tester).
If necessary, to reach the above-mentioned condition, loosen the screws (L) by adjusting the position of the cam (H), and/or by loosening the screws (M) and by adjusting the position of the microswitch (F). Tighten the screws.

**CAUTION!**

If the microswitch connections (I) are disconnected, pay attention to reconnect them on the same contacts and to leave the contact (N) free.

9. Assemble the components by performing steps 3 and 4 in the reverse order.
10. Test the brush operation.

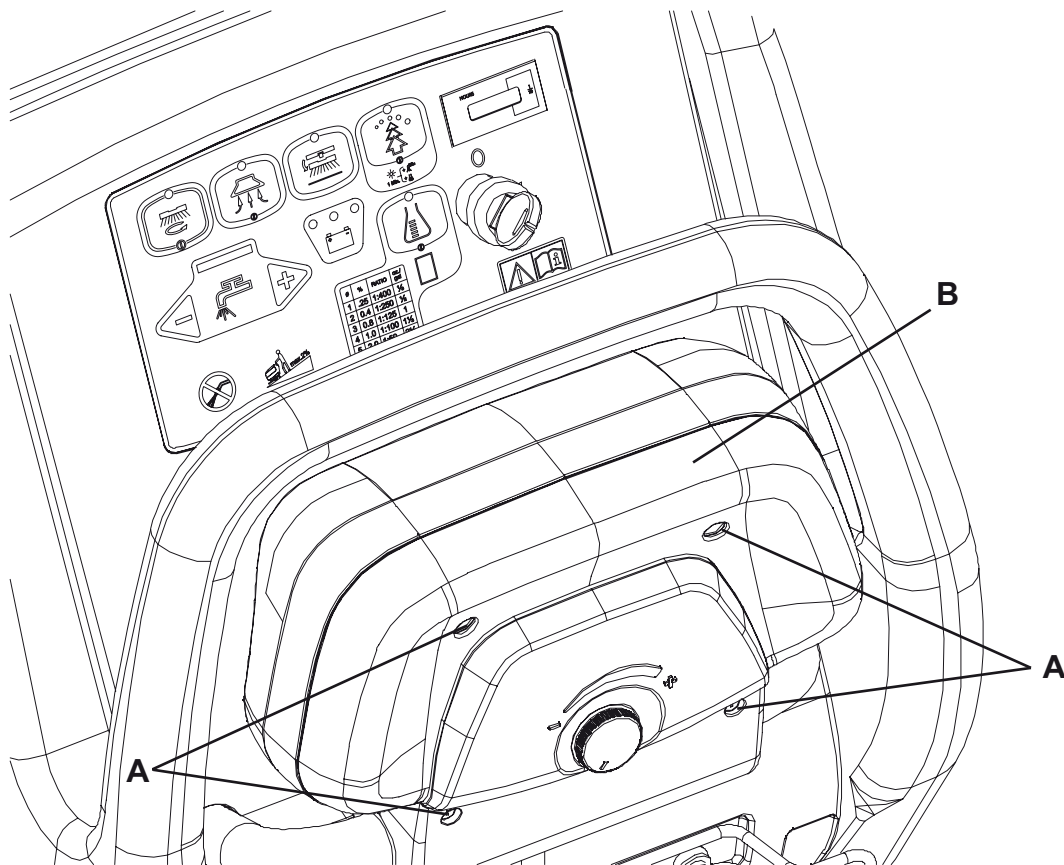

S301549

BRUSHING SYSTEM

BRUSH ENABLING MICROSWITCH ADJUSTMENT/REPLACEMENT (For BA 451D, BA 531D, BA 551D, BA 551CD, BA 611D) (Continues)

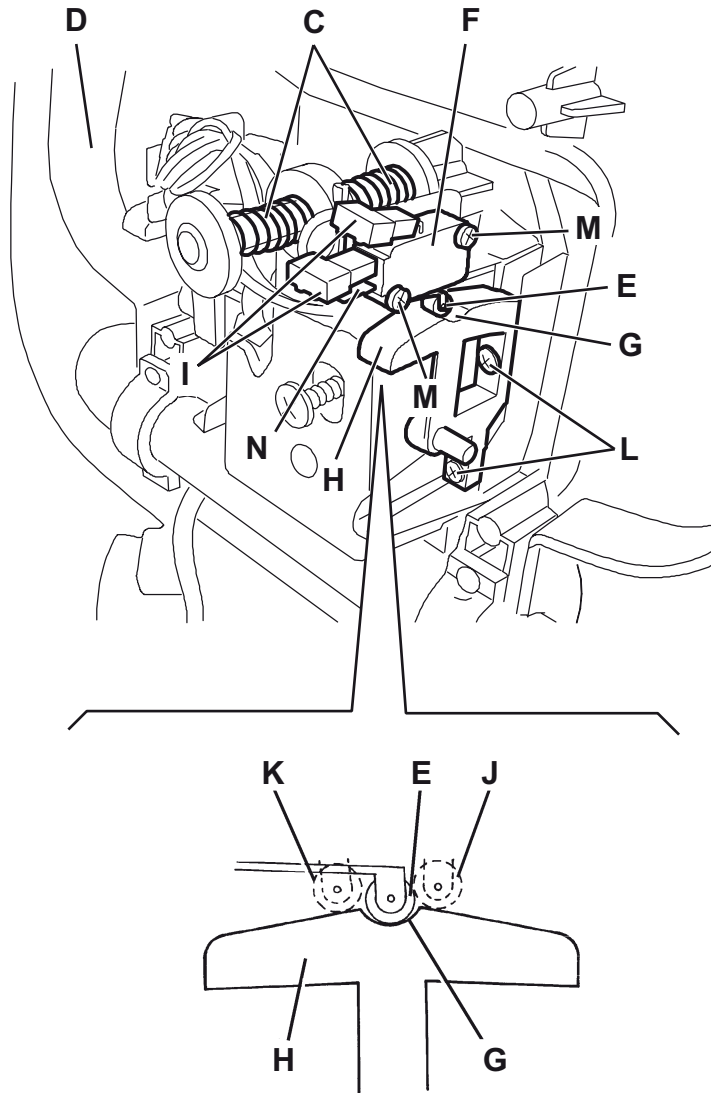

S301550

TROUBLESHOOTING**ALL BRUSHES DO NOT ROTATE****Possible causes**

1. The brush enabling microswitch is misadjusted or broken (adjust or replace).
2. The wiring harness between microswitch and function electronic board is damaged (repair).
3. The brush motor electromagnetic switch wiring harness is damaged (repair).
4. The function electronic board is damaged (replace).
5. The wiring harness between function electronic board and brush motor electromagnetic switch is damaged (repair).
6. The brush motor electromagnetic switch is damaged (replace).
7. The brush motor fuse is open (replace).

ONE BRUSH DO NOT ROTATE (For models with two brushes)**Possible causes**

1. The motor carbon brushes are worn (replace).
2. Bulky debris or cords around the brushes or between the brushes and its flange (remove and clean the brushes).
3. The motor is faulty (repair or replace).
4. The wiring harness is damaged (repair).

RECOVERY WATER SYSTEM

RECOVERY WATER SYSTEM

RECOVERY WATER TANK AND VACUUM GRID CLEANING, AND COVER GASKET CHECK (All models)

1. Drive the machine to the appointed recovery water disposal area.
2.
 - (For **BA 451D**, **BA 531D**, **BA 551D**, **BA 551CD**, **BA 611D**) Turn the ignition key (80) to "0".
 - (For **BA 451**, **BA 531**, **BA 551**) Turn off the switches (71) and (73).
 - (For **CA 451**, **CA 531**, **CA 551**) Disconnect the power supply cable (59) from the electrical mains.
3. Lift the cover (A) to washing position (L).
4. Wash with clean water the cover (A), the tank (B) and the vacuum grid with automatic shut-off float (D).
5. Drain the water in the tank through the hose (16).
If necessary, release the fasteners (E) and open the grid (D), recover the float (F), clean all the components and then reinstall them.
6. Check the tank cover gasket (G) for integrity.



NOTE:

The hole (K), allowing to compensate the air in the cover interspaces, contributes to create vacuum in the tank.

If necessary replace the gasket (G) by removing it from its housing (H). When assembling the new gasket, install the joint (I) in the rear central area, as shown in the figure.

7. Check that the bearing surface (J) of the gasket (G) is integral and adequate for the gasket itself.
8. Check the compensation hole (K) for clogging, and clean it if necessary.



NOTE:

The hole (K), allowing to compensate the air in the cover interspaces, contributes to create vacuum in the tank.

9. Close the cover (A).



NOTE:

Figure showing **BA 551CD**

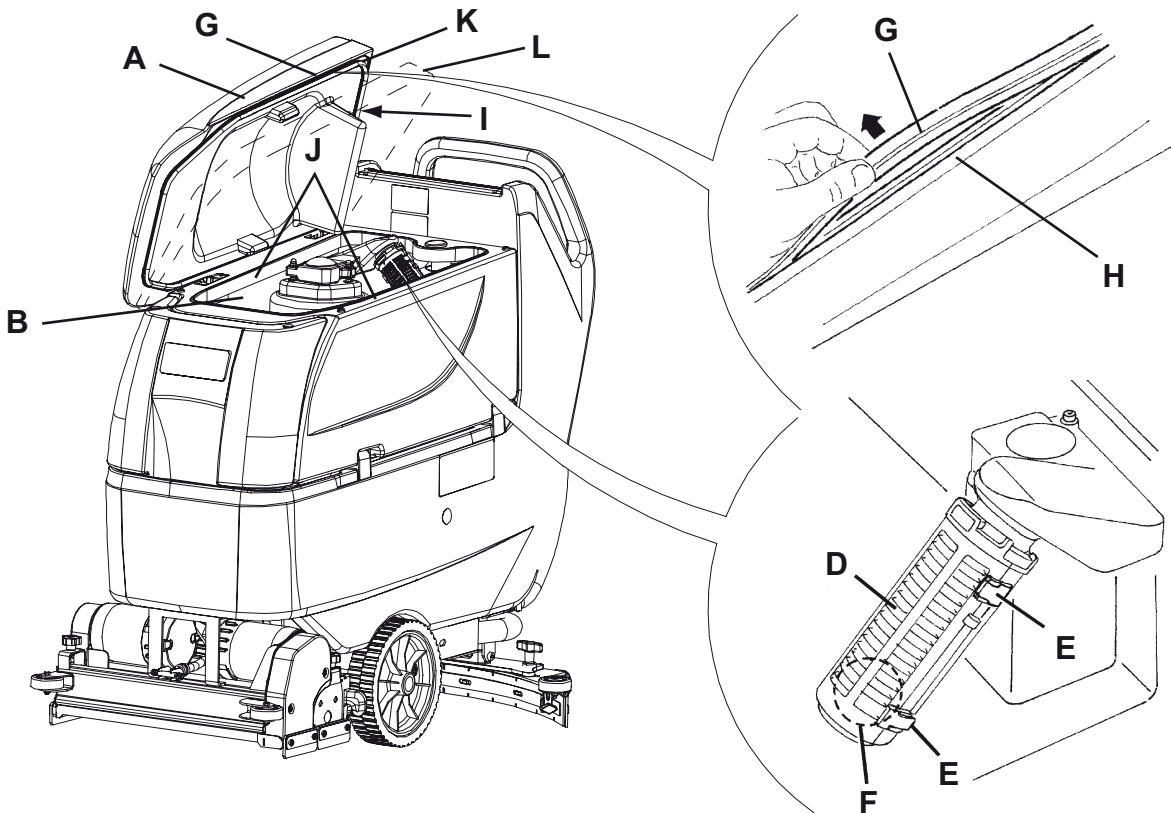

S301551

RECOVERY WATER SYSTEM**SQUEEGEE CLEANING/CHECK/REPLACEMENT AND SQUEEGEE BLADE REPLACEMENT (All models)****CAUTION!**

It is advisable to wear protective gloves when cleaning the squeegee because there may be sharp debris.

Disassembly and cleaning

1. Drive the machine on a level floor.
2. - (For **BA 451D, BA 531D, BA 551D, BA 551CD, BA 611D**) Turn the ignition key (80) to "0".
- (For **BA 451, BA 531, BA 551**) Turn off the switches (71) and (73).
- (For **CA 451, CA 531, CA 551**) Disconnect the power supply cable (59) from the electrical mains.
3. Lower the squeegee (25) with the lever (10).
4. Loosen the handwheels (26) and remove the squeegee (25).
5. Disconnect the vacuum hose (15) from the squeegee.
6. Clean the steel squeegee (Fig. 1) or the aluminium squeegee (Fig. 2). Clean the compartments (A, Fig. 1 or 2) and the hole (B) especially. Check the front blade (C) and the rear blade (D) for integrity, cuts and tears; otherwise replace them (see the procedure in the following paragraph).
7. Install the squeegee in the reverse order of removal.

Check and replacement

8. Clean the steel squeegee (Fig. 1) or the aluminium squeegee (Fig. 2), according to the procedure shown in the previous paragraph.
9. Check that the edges (E, Fig. 1 or 2) of the front blade (C) and the edges (F) of the rear blade (D) lay down on the same level, along their length; otherwise adjust their height according to the following procedure:
 - Release the tie rod (G, Fig. 1 or 2) and loosen the wing nuts (H, Fig. 1), or disengage the fasteners (M, Fig. 2) and adjust the rear blade (D, Fig. 1 or 2), then tighten the wing nuts, or engage the fasteners, and then engage the tie rod.
 - Loosen the handwheels (I) and adjust the front blade (C, Fig. 1 or 2); then tighten the handwheels.
10. Check the front blade (C, Fig. 1 or 2) and rear blade (D) for integrity, cuts and tears; if necessary replace them according to the following procedure. Check that the front corner (J) of the rear blade is not worn; otherwise, overturn the blade to replace the worn corner with an integral one. If the other corners are worn too, replace the blade according to the following procedure:
 - Release the tie rod (G), remove the wing nuts (H) or disengage the fasteners (M), remove the retaining strip (K), then replace/overturn the rear blade (D). Then install the blade in the reverse order of removal.
 - Unscrew the handwheels (I) and remove the retaining strip (L), then replace the front blade (C). Install the blade in the reverse order of removal.After the blade replacement (or overturning), adjust the height as shown in the previous step.
11. Connect the vacuum hose (15) to the squeegee.
12. Install the squeegee (25) and screw down the handwheels (26).
13. If necessary, adjust the squeegee balance adjusting handwheel (27).

RECOVERY WATER SYSTEM

SQUEEGEE CLEANING/CHECK/REPLACEMENT AND SQUEEGEE BLADE REPLACEMENT (All models) (Continues)

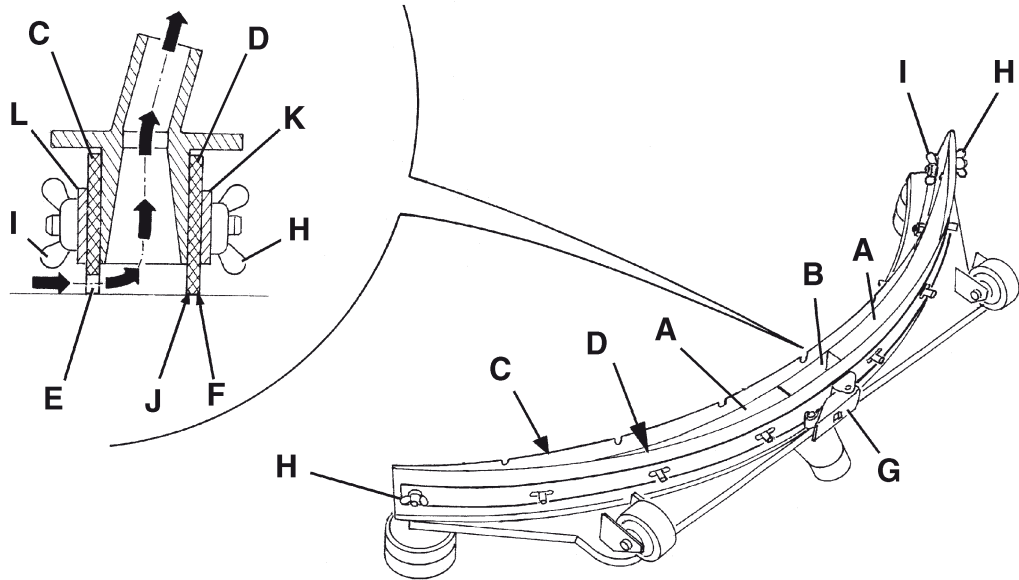

Fig. 1

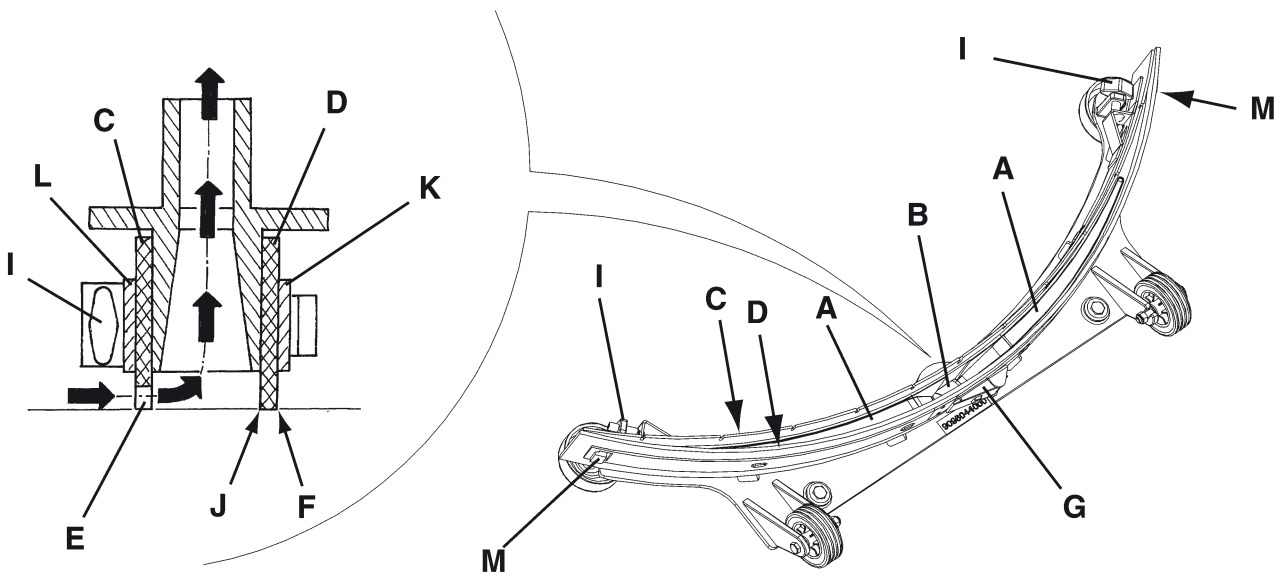

Fig. 2

S301552

RECOVERY WATER SYSTEM**VACUUM SYSTEM MOTOR FILTER CLEANING (All models)****Disassembly and cleaning**

1. If the tank (21) contains recovery water:
 - Drive the machine to the appointed recovery water disposal area.
 - (For **BA 451D, BA 531D, BA 551D, BA 551CD, BA 611D**) Turn the ignition key (80) to "0".
 - (For **BA 451, BA 531, BA 551**) Turn off the switches (71) and (73).
 - (For **CA 451, CA 531, CA 551**) Disconnect the power supply cable (59) from the electrical mains.
 - Empty the recovery water tank (21) with the hose (16).
2. Drive the machine on a level floor.
3.
 - (For **BA 451D, BA 531D, BA 551D, BA 551CD, BA 611DD**) Turn the ignition key (80) to "0".
 - (For **BA 451, BA 531, BA 551**) Turn off the switches (71) and (73).
 - (For **CA 451, CA 531, CA 551**) Disconnect the power supply cable (59) from the electrical mains.
4. (For **CA 451, CA 531, CA 551**) Open the recovery water tank cover (22). Remove the retaining plate (61) of the tank (40).
5. Grasp the handle (41) and carefully lift the tank (40).
6. Remove the vacuum system motor filter (44) and clean it with water and compressed air.
7. Install the filter (44).

Assembly

8. Assemble the components in the reverse order of disassembly.

**WARNING!**

(For CA 451, CA 531, CA 551) When the maintenance/repair procedure is completed, the tank (40) must always be locked with the plate (61).

RECOVERY WATER SYSTEM

VACUUM SYSTEM MOTOR ELECTRICAL INPUT CHECK (For BA 451, BA 451D, BA 531, BA 531D, BA 551, BA 551D, BA 551CD, BA 611D)

WARNING!

This procedure must be performed by qualified personnel only.

1. If the tank (21) contains recovery water:
 - Drive the machine to the appointed recovery water disposal area.
 - (For **BA 451D, BA 531D, BA 551D, BA 551CD, BA 611D**) Turn the ignition key (80) to "0".
 - (For **BA 451, BA 531, BA 551**) Turn off the switches (71) and (73).
 - Empty the recovery water tank (21) with the hose (16).
2. Drive the machine on a level floor.
3.
 - (For **BA 451D, BA 531D, BA 551D, BA 551CD, BA 611D**) Turn the ignition key (80) to "0".
 - (For **BA 451, BA 531, BA 551**) Turn off the switches (71) and (73).
4. Disconnect the battery connector (12).
5. Grasp the handle (41) and carefully lift the tank (40).
6. Apply the amperometric pliers (A) on one cable (B) of the batteries.
7. (For **BA 451D, BA 531D, BA 551D, BA 551CD, BA 611D**) Turn the ignition key (80) to "I".
8. Turn on the vacuum system by pressing the switch (73) and check that the motor electrical input is 16 - 19 A at 24 V. Turn off the vacuum system by pressing the switch (73).

Remove the amperometric pliers (B).

If the electrical input exceeds the specifications, check the motor carbon brushes (see the procedure in the relevant paragraph).

If necessary, disassemble the vacuum system motor (see the procedure in the relevant paragraph), and check the condition of all its components.

If the above-mentioned procedures do not lead to a correct electrical input, the motor must be replaced (see the procedure in the relevant paragraph).

9. Perform steps 4 and 5 in the reverse order.

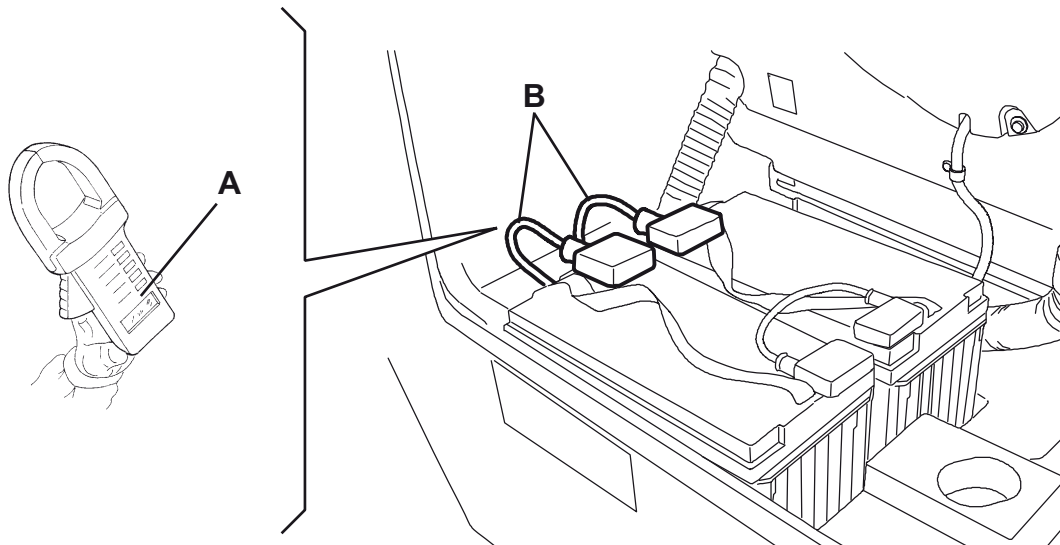

S301553

RECOVERY WATER SYSTEM**VACUUM SYSTEM MOTOR ELECTRICAL INPUT CHECK (For CA 451, CA 531, CA 551)****WARNING!**

This procedure must be performed by qualified personnel only.

Check

1. Remove the brush, as shown in the User Manual.
2. Disconnect the power supply cable (59) from the electrical mains but do not place it on the holder (60).
3. If the power supply cable (59) is on the holder (60), remove it.
4. Move aside the recovery water drain hose (16).
5. Remove the mounting screws (A) of the panel (C).
6. Loosen the mounting screws (B) of the panel (C).
7. Carefully move backwards the upper end (D) of the panel (C).
8. Apply the amperometric pliers (E) on one cable (F) of the vacuum system motor.
9. Connect the power supply cable (59) to the electrical mains.
10. Turn on the vacuum system by pressing the switch (63) and check that the motor electrical input is 2 - 2.5 A at 230 V. Turn off the vacuum system by pressing the switch (63).
Disconnect the power supply cable (59) from the electrical mains.
Remove the amperometric pliers (E).
If the electrical input is higher, perform the following procedures to detect and correct the abnormal input:
 - Check that the filter (44) is clean (see the procedure in the relevant paragraph).
 - Check that the vacuum grid with automatic shut-off float is clean (see the procedure in the relevant paragraph).
 - Check that the squeegee and the vacuum hose are clean (see the procedure in the relevant paragraph).
 - Check the motor carbon brushes (see the procedure in the relevant paragraph).If the above-mentioned procedures do not lead to a correct electrical input, the motor must be replaced (see the procedure in the relevant paragraph).

Reset

11. Perform steps 3 to 7 in the reverse order.

RECOVERY WATER SYSTEM

VACUUM SYSTEM MOTOR ELECTRICAL INPUT CHECK (For CA 451, CA 531, CA 551) (Continues)

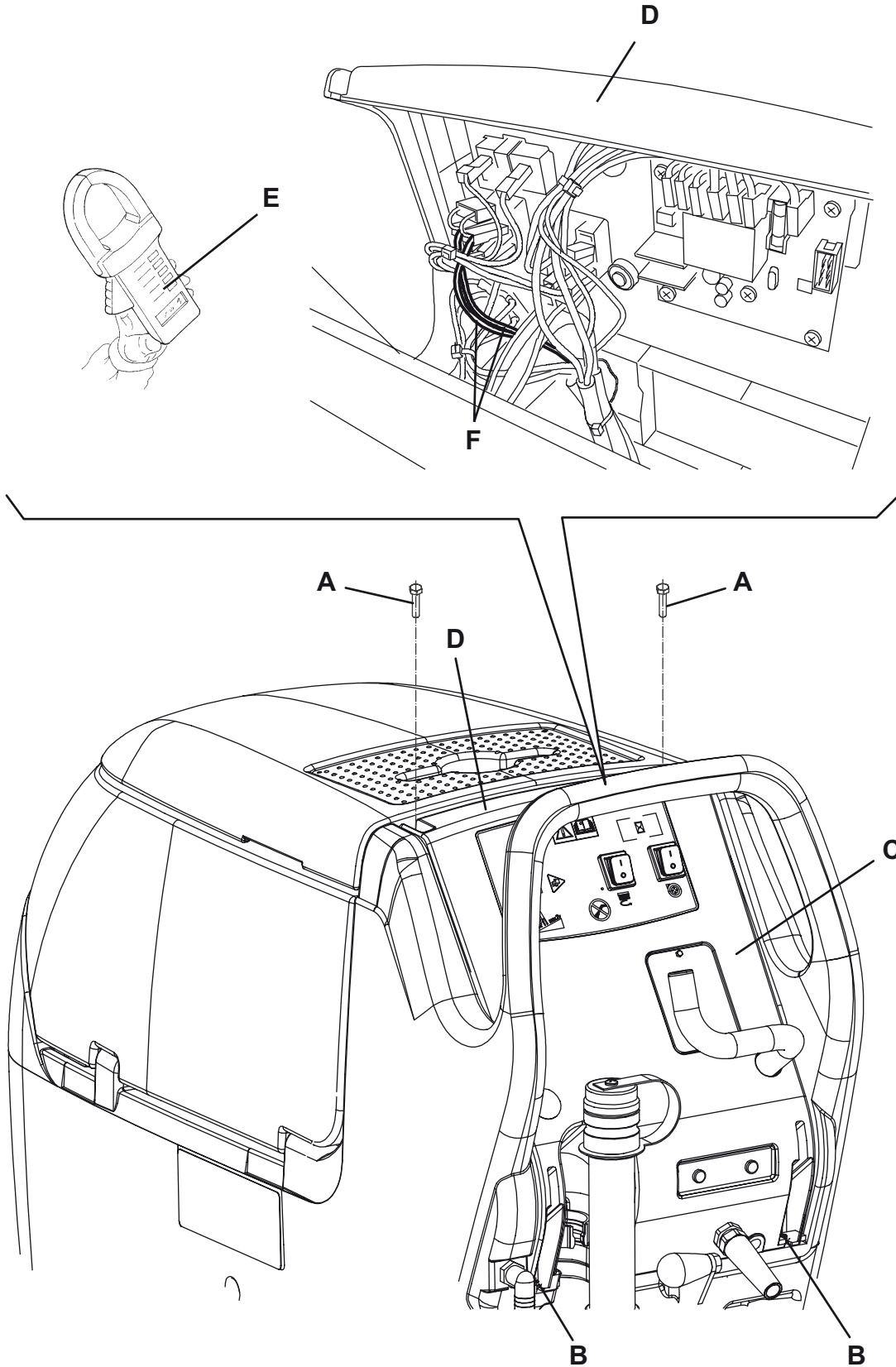

S301554

RECOVERY WATER SYSTEM**VACUUM SYSTEM MOTOR CARBON BRUSH CHECK/REPLACEMENT (All models)**

1. Remove the vacuum system motor (see the procedure in the relevant paragraph).
2. At the workbench, remove the cover (A) (press-fitted) from the vacuum system motor (B).
3. Remove the screws (C).
4. Disconnect the electrical connections (D).
5. Remove the carbon brushes (E).
6. Check the carbon brushes for wear. Replace the carbon brushes when: the contact with the motor armature is insufficient, the carbon brushes are worn, the carbon brush contact surface is not integral, the thrust spring is broken, etc.
7. If necessary, replace the carbon brushes. Replace the carbon brushes as an assembly.
8. Assemble the components in the reverse order of disassembly.

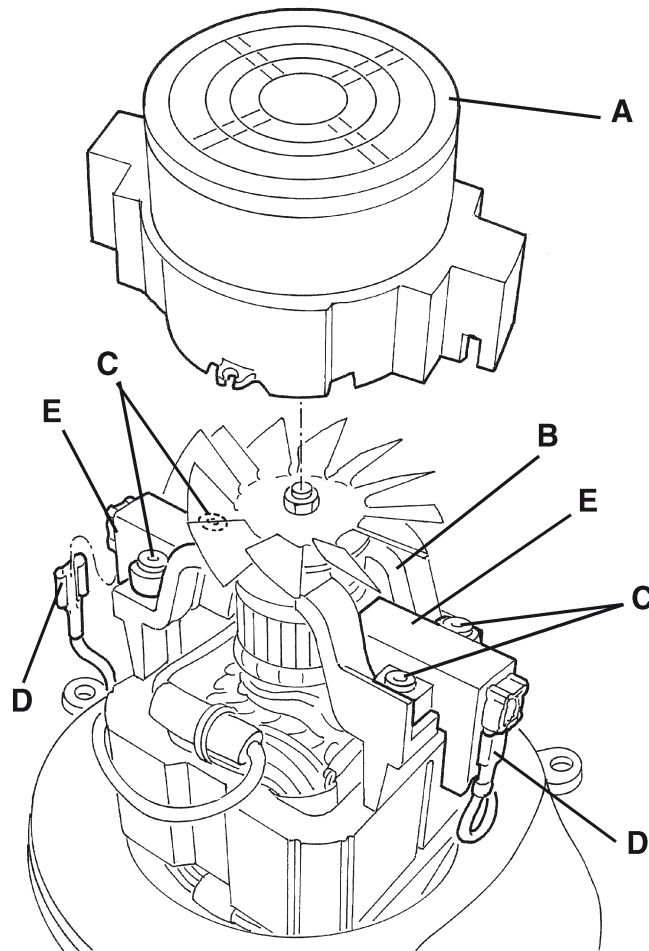

S301555

RECOVERY WATER SYSTEM

VACUUM SYSTEM MOTOR DISASSEMBLY/ASSEMBLY (All models)

Disassembly

1. If the tank (21) contains recovery water:
 - Drive the machine to the appointed recovery water disposal area.
 - (For **BA 451D, BA 531D, BA 551D, BA 551CD, BA 611D**) Turn the ignition key (80) to "0".
 - (For **BA 451, BA 531, BA 551**) Turn off the switches (71) and (73).
 - (For **CA 451, CA 531, CA 551**) Disconnect the power supply cable (59) from the electrical mains.
 - Empty the recovery water tank (21) with the hose (16).
2. Drive the machine on a level floor.
3.
 - (For **BA 451D, BA 531D, BA 551D, BA 551CD, BA 611D**) Turn the ignition key (80) to "0".
 - (For **BA 451, BA 531, BA 551**) Turn off the switches (71) and (73).
 - (For **CA 451, CA 531, CA 551**) Disconnect the power supply cable (59) from the electrical mains.
4. (For **BA 451, BA 451D, BA 531, BA 531D, BA 551, BA 551D, BA 551CD, BA 611D**) Disconnect the battery connector (12).
5. (For **CA 451, CA 531, CA 551**) Remove the retaining plate (61) of the tank (40).
6. Grasp the handle (41) and carefully lift the tank (40).
7. Remove the screws (A) and recover the washers.
8. Remove the motor cover (B).
9. Remove the filter (C) and the gasket (D).
10. Remove the motor (E) or (L), the sound-deadening pipe (F) and the sound-deadening panel (G).
11.
 - (For **BA 451, BA 451D, BA 531, BA 531D, BA 551, BA 551D, BA 551CD, BA 611D**) Disconnect the electrical connector (H) of the motor (E).
 - (For **CA 451, CA 531, CA 551**) Disconnect two electrical connections (J) and (K) of the motor (L).
12. Check the efficiency of the gasket (I) and, if necessary, replace it.

Assembly

13. Assemble the components in the reverse order of disassembly, and note the following:
 - If necessary, clean the filter (C) before assembling it (see the procedure in the relevant paragraph).

**WARNING!**

(For CA 451, CA 531, CA 551) When the maintenance/repair procedure is completed, the tank (40) must always be locked with the plate (61).

RECOVERY WATER SYSTEM

VACUUM SYSTEM MOTOR DISASSEMBLY/ASSEMBLY (All models) (Continues)

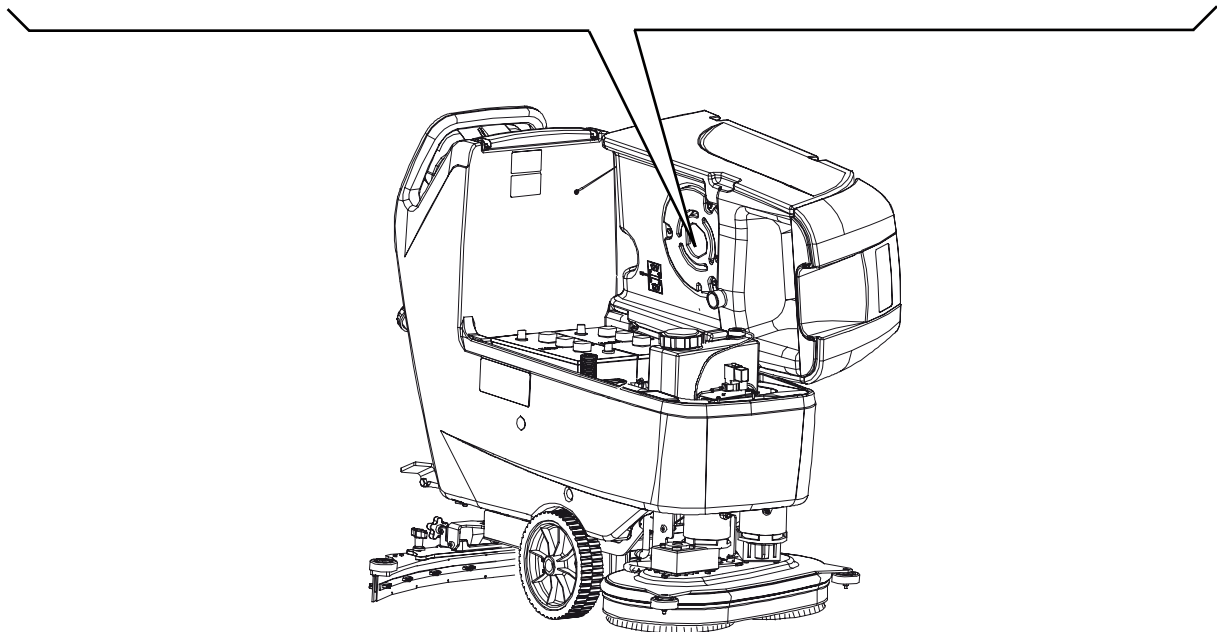
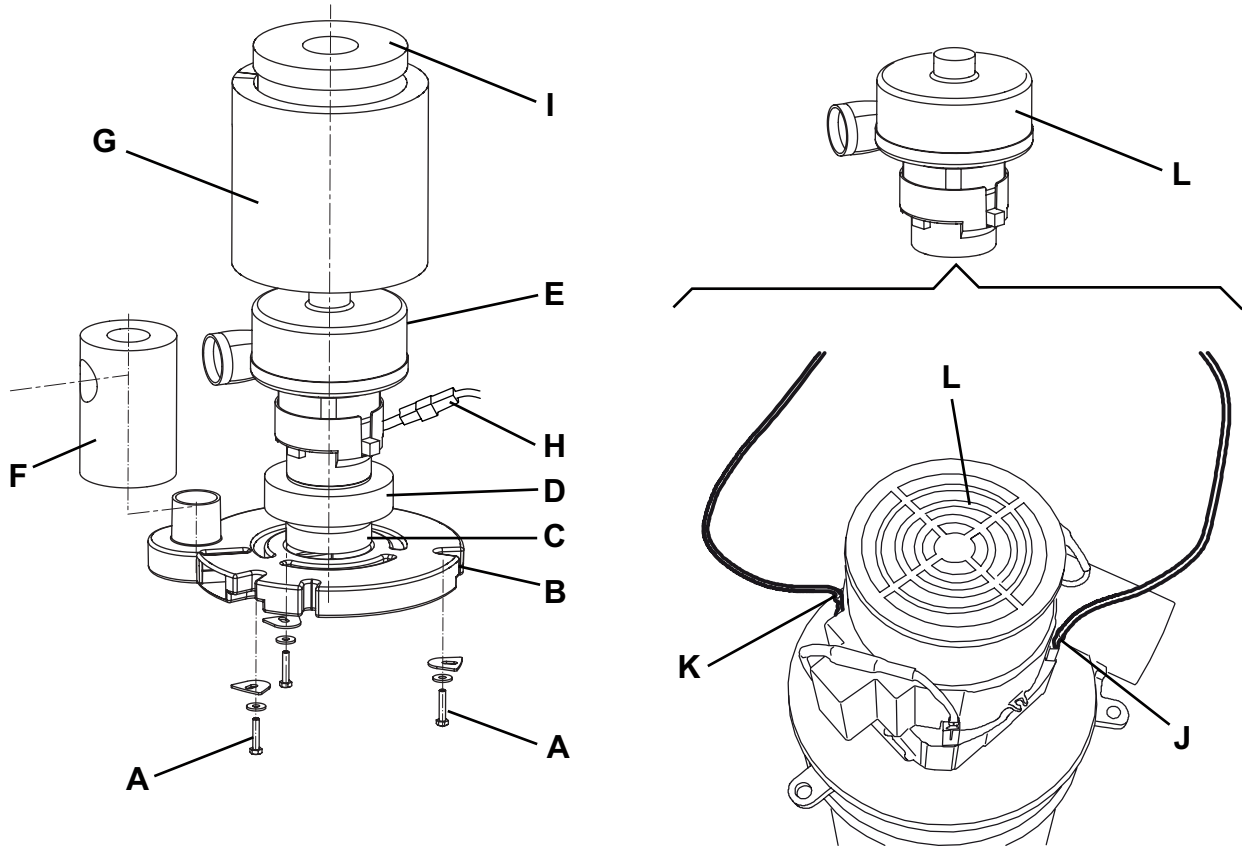

S301556

RECOVERY WATER SYSTEM

SQUEEGEE SPRING CHECK/REPLACEMENT (All models, with aluminium squeegee)

Check

1. Drive the machine on a level floor.
2. - (For **BA 451D**, **BA 531D**, **BA 551D**, **BA 551CD**, **BA 611D**) Turn the ignition key (80) to "0".
- (For **BA 451**, **BA 531**, **BA 551**) Turn off the switches (71) and (73).
- (For **CA 451**, **CA 531**, **CA 551**) Disconnect the power supply cable (59) from the electrical mains.
3. Check that the springs (A) and (B) push the squeegee (C) on the floor correctly.
4. If necessary, disassemble and replace the springs according to the following procedure.

Disassembly

5. Remove the squeegee (see the procedure in the relevant paragraph).
6. Lift the deck by pressing the pedal (11).
7. Grasp the handlebar (2) and lower the front part of the machine.
8. Remove the cotter pin (D).
9. Disengage the end (E) of the left spring (F) from the housing (G).
10. Remove the left spring (F).
11. Repeat steps 8, 9 and 10 for the right spring (H).

Assembly

12. Assemble the springs by performing steps 5 to 11 in the reverse order.

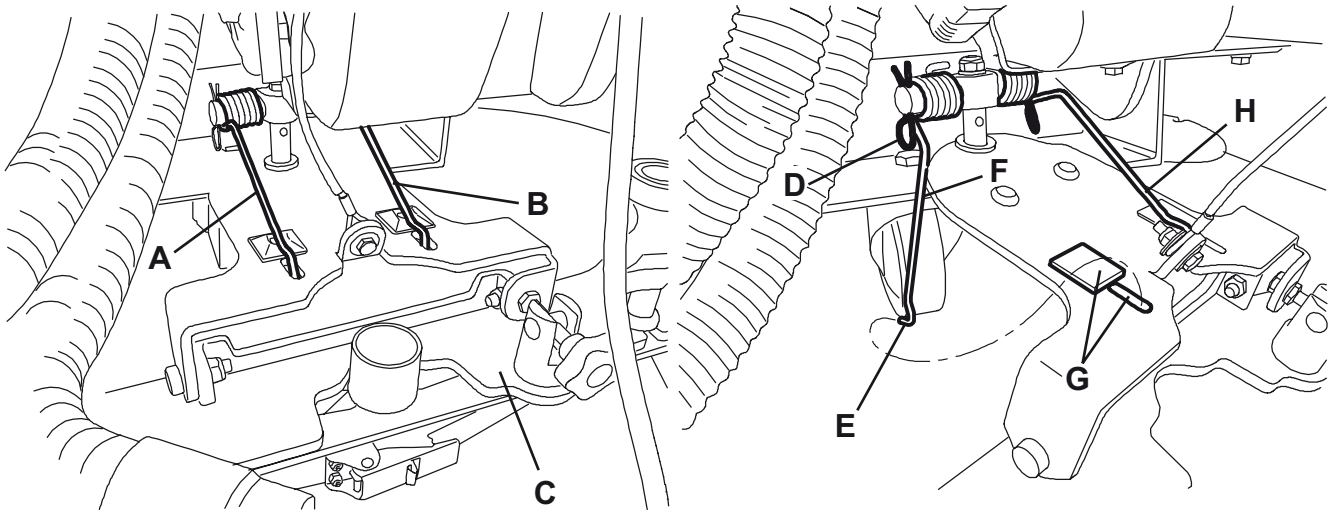

S301557

RECOVERY WATER SYSTEM

TROUBLESHOOTING

THE VACUUM SYSTEM MOTOR DOES NOT TURN ON

1. The wiring harness between the function electronic board and the vacuum system relay is damaged or short-circuited (check and repair).
2. The vacuum system relay is damaged (replace).
3. The wiring harness between relay and motor is damaged (repair).
4. The vacuum system fuse is open (replace).
5. The vacuum system motor carbon brushes are worn (replace).
6. The vacuum system motor is faulty (check the electrical input).
7. The function electronic board is damaged (replace).

DIRTY WATER VACUUMING IS INSUFFICIENT OR THERE IS NO VACUUMING

Possible causes

1. The vacuum grid with automatic shut-off float is activated because the recovery water tank is full (empty the recovery water tank).
2. The vacuum grid with automatic shut-off float is dirty, or the vacuum pre-filter is dirty (clean).
3. The tank cover is not correctly positioned (adjust).
4. The tank cover gasket is not efficient, or the compensating hole is clogged (repair/clean).
5. The vacuum system motor filter is dirty (clean).
6. The squeegee or the vacuum hose is clogged or damaged (clean or repair/replace).
7. The vacuum gaskets are damaged or do not match perfectly (repair or replace).

THE SQUEEGEE LEAVES LINING ON THE FLOOR OR DOES NOT COLLECT WATER

Possible causes

1. There is debris under the blade (remove).
2. The squeegee blade edges are torn or worn (replace).
3. The squeegee is not balanced (adjust it with the relevant handwheel).
4. (For aluminium squeegee) The squeegee springs are not efficient (check/replace).

DRIVE SYSTEM

DRIVE SYSTEM

SPEED POTENTIOMETER ADJUSTMENT/REPLACEMENT (For BA 451D, BA 531D, BA 551D, BA 551CD, BA 611D)

1. Disconnect the battery connector (12).
2. Move aside the recovery water drain hose (16).
3. Remove the battery charger cable (6), if equipped, from the cable holder (7).
4. Remove the screws (A) and carefully move aside the panel (B) by disengaging the cable grommet (C) from its housing on the panel (B).
5. Disconnect the drive paddle connector (D).
6. Remove the screws (E) and move the drive paddle cover (F).
7. Check that the springs (G) operate correctly when releasing the drive paddle (H).
8. Cut the fastening clamp (I) of the connector (J).
9. Disconnect the potentiometer connector (J).
10. Connect the tester (K) on the connections "3" and "5" of the connector (D) (to locate the connections "3" and "5", refer to the numbers shown on the cables (L)), then check for the following:
 - When the paddle (H) is released, measure $2.5\text{ K}\Omega \pm 0.1\text{ K}\Omega$
 - When the paddle (H) is completely pushed forward, measure $5.0\text{ K}\Omega \pm 0.1\text{ K}\Omega$
 - When the paddle (H) is completely pulled rearward, measure $0.0\text{ K}\Omega \pm 0.1\text{ K}\Omega$
 If necessary, to adjust the values, loosen the screw (O), loosen the nut (M) and slightly turn the potentiometer (N) as necessary. After adjusting, tighten the nut (M) and the screw (O).
 To adjust the value, when the paddle is completely pushed forward, it is possible to operate on the mechanical end-of-stroke screw (P). Remove the tester (K).
11. If necessary, replace the potentiometer according to the following procedure:
 - Loosen the screw (O).
 - Remove the screws (Q).
 - Remove the cam (R) and the connecting rod (S).
 - Cut the fastening clamp (I) and disconnect the connector (J).
 - Unsold the terminals (T), then unscrew the nut (M) and remove the potentiometer (N).
 - Install the new potentiometer in the reverse order of removal.
 - Adjust the cam (R) until the connecting rod (S) turns freely, then tighten the screws (Q).
 - Perform the adjustment shown in step 10.
 - Apply paint (U) on the nut (M).
12. Assemble the components by performing steps 1 to 9 in the reverse order.
13. Test the drive system and speed.

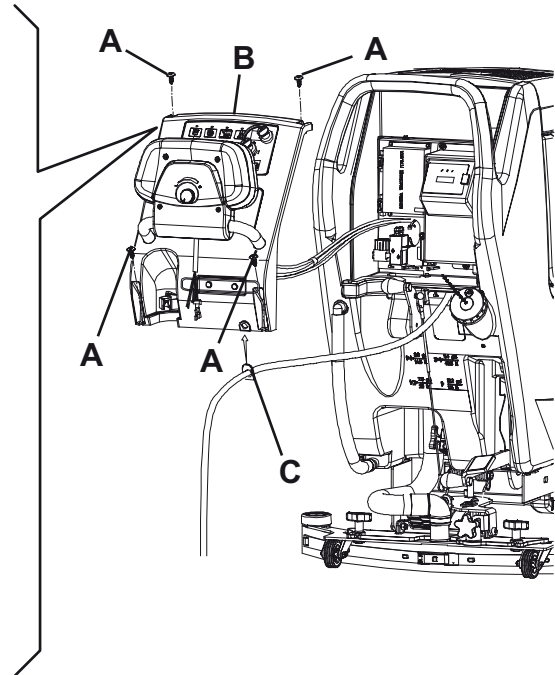
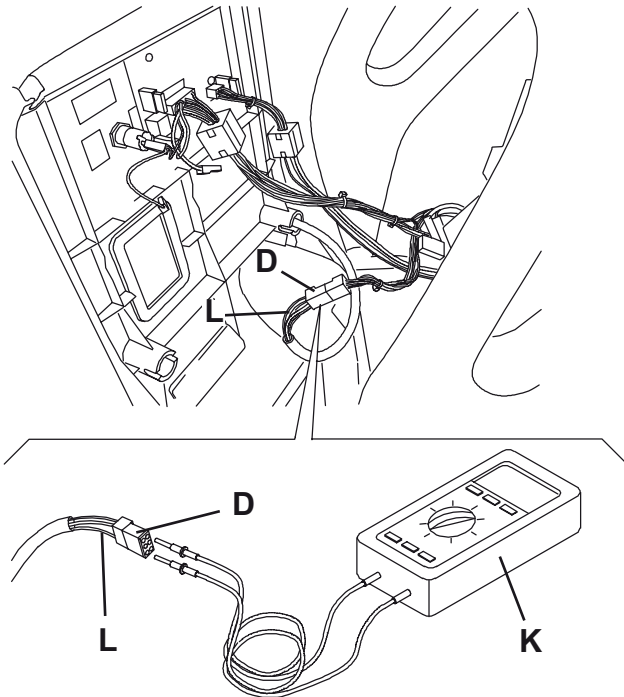

S301558

DRIVE SYSTEM

SPEED POTENTIOMETER ADJUSTMENT/REPLACEMENT (For BA 451D, BA 531D, BA 551D, BA 551CD, BA 611D) (Continues)

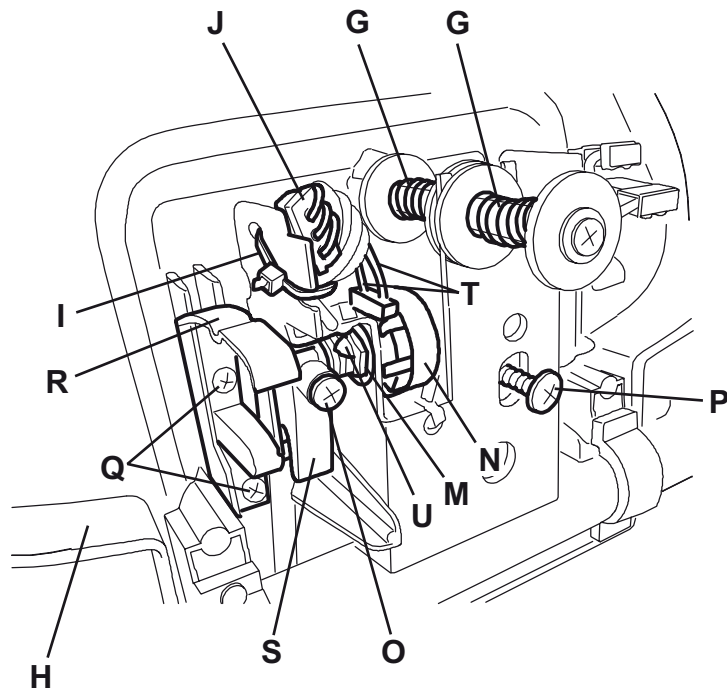
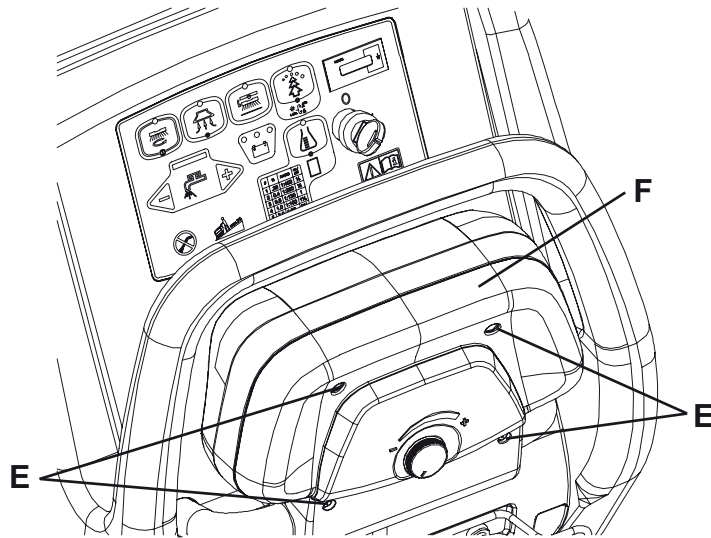

S301559

DRIVE SYSTEM

MAXIMUM SPEED POTENTIOMETER DISASSEMBLY/ASSEMBLY (For BA 451D, BA 531D, BA 551D, BA 551CD, BA 611D)

Disassembly

1. Disconnect the battery connector (12).
2. Operating inside the hole (A), loosen the threaded dowel and remove the maximum speed adjuster knob (B).
3. Unscrew the potentiometer mounting nut (C).
4. Remove the screws (D) and move the cover (E).
5. Cut the fastening clamp (F) and disconnect the potentiometer connector (G).
6. Open the clamp (H).
7. Remove the potentiometer with the relevant wiring harness (I).

Assembly

8. Assemble the components in the reverse order of disassembly, and note the following:
 - Fasten the knob (B) with the potentiometer shaft (L) completely turned to the left and the hole (A) in the lower centre part of the panel as shown in the figure.
9. Test the drive system and the maximum speed change.

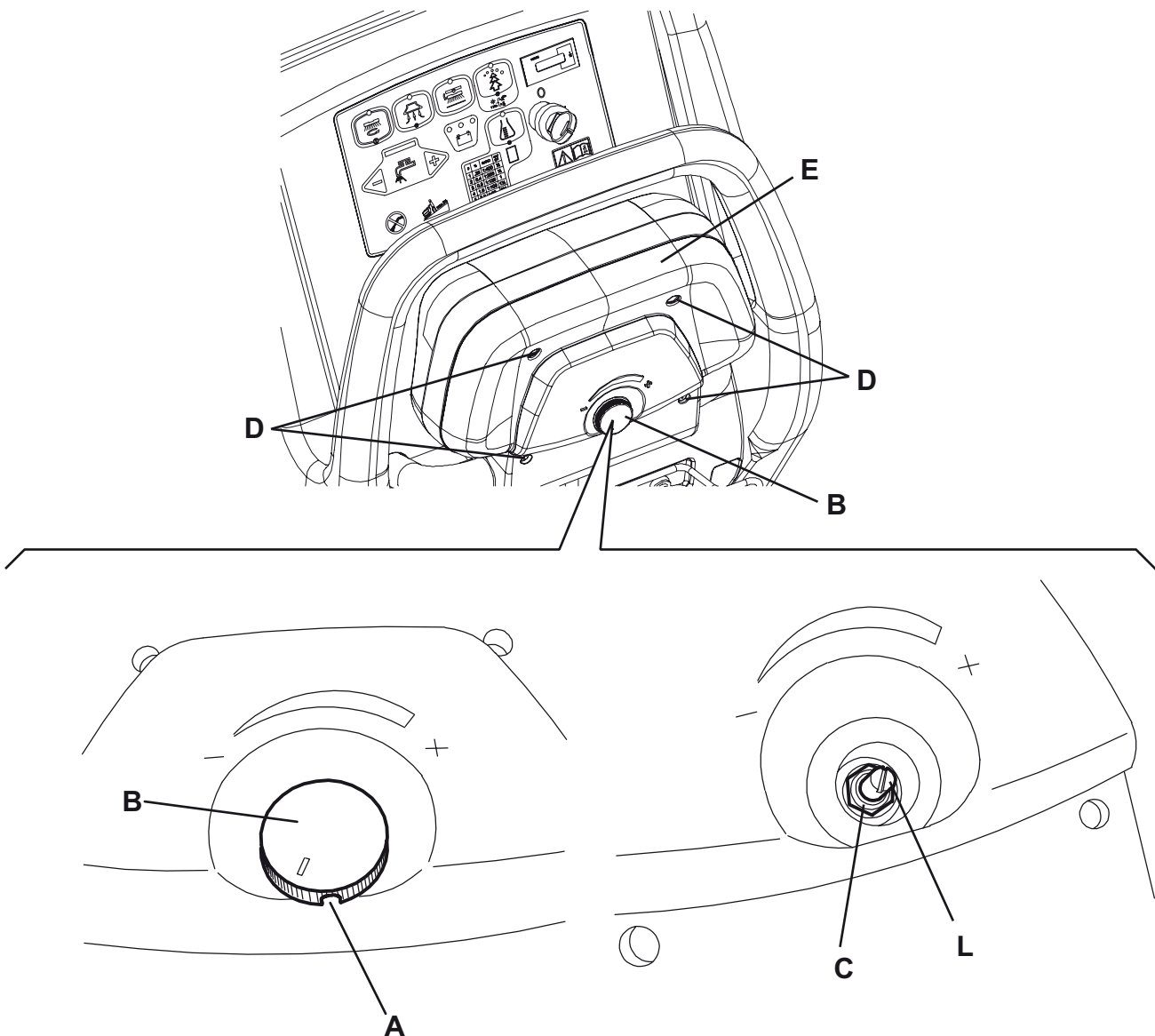

S301560

DRIVE SYSTEM

MAXIMUM SPEED POTENTIOMETER DISASSEMBLY/ASSEMBLY (For BA 451D, BA 531D, BA 551D, BA 551CD, BA 611D) (Continues)

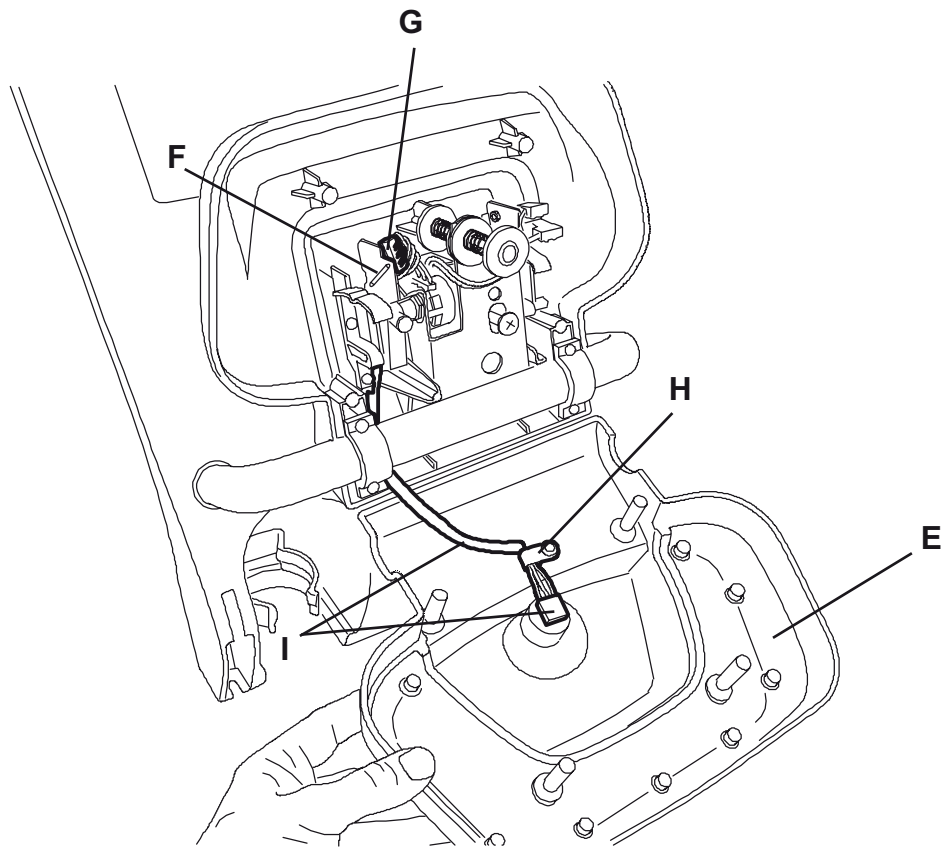

S301561

DRIVE SYSTEM

DRIVE SYSTEM MOTOR ELECTRICAL INPUT CHECK (For BA 451D, BA 531D, BA 551D, BA 551CD, BA 611D)

**WARNING!**

This procedure must be performed by qualified personnel only and with the help of an assistant.

1. Check that the batteries are completely charged, otherwise charge them as shown in the User Manual.
2. If the tank (21) contains recovery water:
 - Drive the machine to the appointed recovery water disposal area.
 - Turn the ignition key (80) to "0".
 - Empty the recovery water tank (21) with the hose (16).
3. Drive the machine on a level floor.
4. Lower the deck by pressing the pedal (11).
5. Under the left side the machine, install a suitable jack (C) in the position (A), and slightly lift the machine so that the left wheel (C) can turn freely, without touching the floor or the jack.

**WARNING!**

While performing this procedure, pay attention to the rotation of the driving wheel (C).

6. Apply the amperometric pliers (D) on one cable (E) of the drive system motor.
7. Turn the ignition key (80) to "I".
8. Turn the speed adjuster (4) to the maximum speed.
9. With the help of an assistant who firmly keeps the machine by the handlebar, push the drive paddle (3) completely forward and check that the electrical input is 1.5 - 2.5 A at 24 V. Release the drive paddle (3). Turn the ignition key (80) to "0" and remove the amperometric pliers (D).

If the electrical input is higher, perform the following procedures to detect and correct the abnormal input:

 - Check if there is dust or debris preventing the component rotation. The lifted wheel (C) must turn freely with a slight resistance of the differential.
 - If necessary, disassemble the motor-differential (see the procedure in the relevant paragraph) then check for hub correct alignment and bearing smooth running.

If the above-mentioned procedures do not lead to a correct electrical input, the motor must be replaced (see the procedure in the relevant paragraph).
10. Perform steps 4 and 5 in the reverse order.

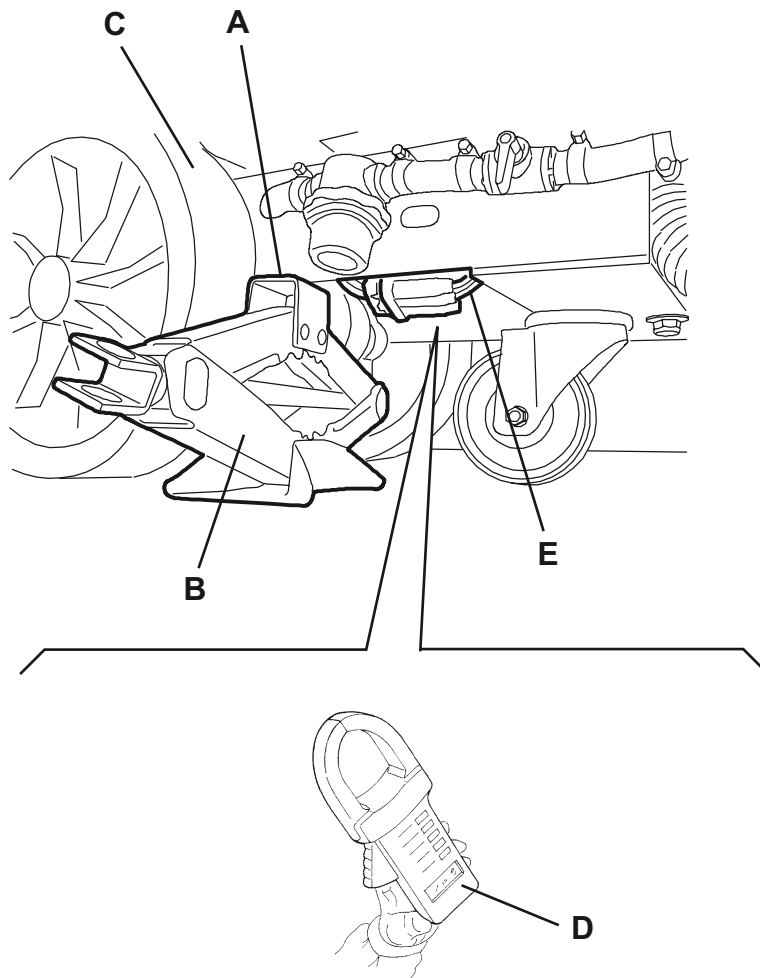
DRIVE SYSTEM**DRIVE SYSTEM MOTOR ELECTRICAL INPUT CHECK (For BA 451D, BA 531D, BA 551D, BA 551CD, BA 611D) (Continues)**

S301562

DRIVE SYSTEM

DRIVE SYSTEM MOTOR CARBON BRUSH CHECK AND REPLACEMENT (For BA 451D, BA 531D, BA 551D, BA 551CD, BA 611D)

1. Drive the machine to the appointed disposal area, and empty the recovery water tank (21) with the hose (16).
2. Place the machine on a hoisting system (if available).
Otherwise, drive the machine on a level floor.
3. Turn the ignition key (80) to "0".
4. Disconnect the battery connector (12).
5. Operating on the left side of the machine, clean the drive system motor (B) in the area of the covers (A).
6. Unscrew the covers (A) and remove the carbon brushes (C).
7. Check if the carbon brushes (C) are worn. Replace the carbon brushes when: the contact with the motor armature is insufficient, the carbon brushes are worn, the carbon brush contact surface is not integral, the thrust spring is broken, etc. If necessary, replace the carbon brushes. Replace the carbon brushes as an assembly.
8. Assemble the components in the reverse order of disassembly.

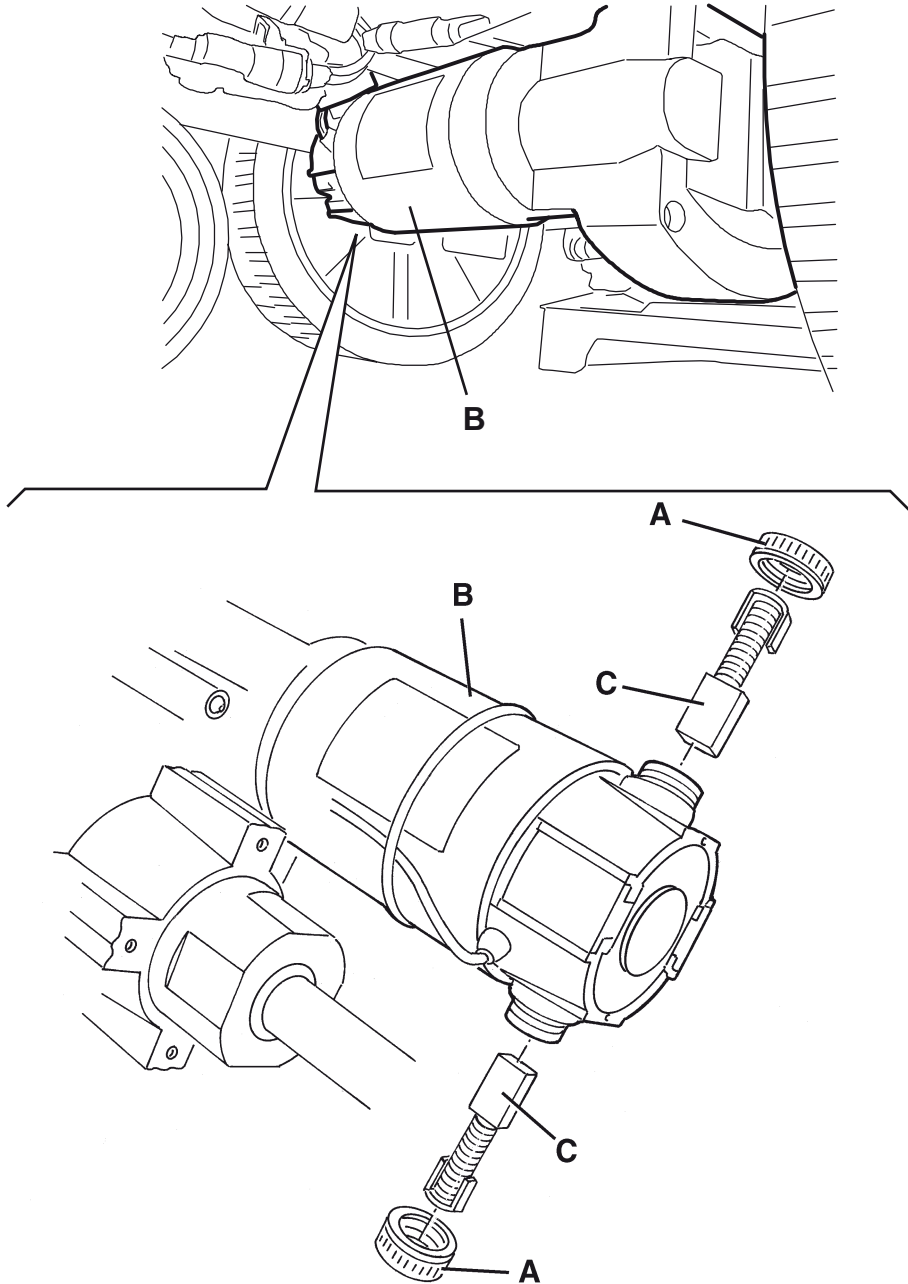

S301563

DRIVE SYSTEM

DRIVE SYSTEM MOTOR-DIFFERENTIAL DISASSEMBLY/ASSEMBLY (For BA 451D, BA 531D, BA 551D, BA 551CD, BA 611D)

Disassembly

1. If the tank (21) and/or (20) contains recovery water:
 - Drive the machine to the appointed disposal area.
 - Turn the ignition key (80) to "0".
 - Empty the recovery water tank (21) with the hose (16).
 - Empty the solution/clean water tank (20) with the hose (17).
2. Remove the squeegee (see the procedure in the relevant paragraph).
3. Remove the batteries (see the procedure in the relevant paragraph).
4. Prepare an hoisting system (A) on which the machine is to be laid on one side. Place a panel (B) on the hoisting system to avoid damaging the machine.
5. With the help of an assistant, tilt the machine on one side and lay it on the panel (B).
6. Remove the screws (C), then remove the wheels (D) and recover the keys (E).
7. Remove the screws (F) on both sides.
8. Disconnect the connectors (G) of the drive system motor.
9. If necessary, remove the spacers (I) and the retaining rings.
10. Remove the motor-differential (J).

Assembly

11. Assemble the components in the reverse order of disassembly.

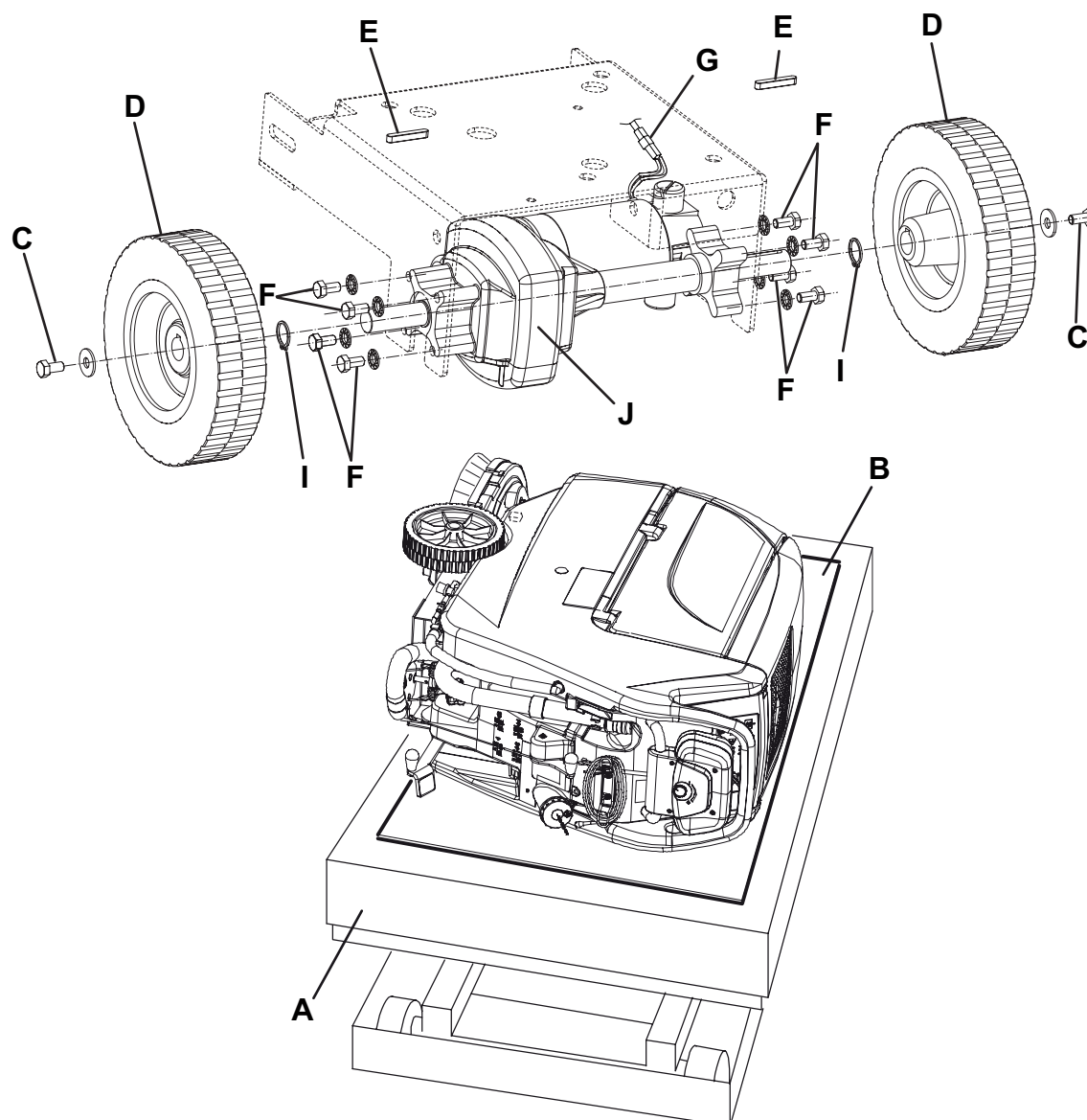

S301564

DRIVE SYSTEM

TROUBLESHOOTING

OPEN CIRCUIT

Possible causes

1. There are bulky debris or cords under the machine or around the driving wheels (remove the debris).
2. The motor is damaged (check the motor electrical input).
3. The floor gradient is excessive (do not use the drive system on slopes with a gradient exceeding the specifications).
4. There is a short circuit in the drive system electronic board harness (repair).
5. The drive system electronic board is faulty (replace).

THE MACHINE DOES NOT MOVE

Possible causes

1. The battery voltage is too low (charge the batteries).
2. The drive paddle potentiometer is misadjusted or broken (adjust or replace).
3. The speed adjuster is broken (replace).
4. The drive system enabling microswitch is misadjusted or broken (adjust or replace).
5. The drive system electronic board is faulty (replace).
6. There is an open in the fuse (repair).
7. The wiring harness is damaged (repair).
8. The drive system motor carbon brushes are worn (replace).
9. The drive system motor is faulty (replace).

DRIVE SYSTEM

TROUBLESHOOTING (Continues)

DRIVE SYSTEM ELECTRONIC BOARD DIAGNOSTIC TABLE

No. of flashes (*)	Meaning	Action
1	Drive system/brush enabling microswitch closed when starting the machine	Check the microswitch adjustment
2	Faulty speed potentiometer	Check both speed potentiometers
3	Faulty speed potentiometer	Check both speed potentiometers
4	Speed potentiometer off neutral when starting the machine	Check the speed potentiometer adjustment
5	Thermal protection	Check the drive system motor electrical input
6	Faulty drive system electronic board	Replace the drive system electronic board
7	Overcurrent output	Check the drive system motor electrical input; if the electrical input is normal, replace the drive system electronic board
8	Missing power connection	Check the drive system fuse and the drive system electronic board wiring harness; if the fuse and the wiring harness are normal, replace the drive system electronic board
9	Low battery voltage	Charge the batteries
10	High battery voltage	Check the batteries
11	Overload output	Check the drive system motor electrical input
12	(Not applicable)	--
13	Ignition key wrong sequence	Check for false contacts in the ignition key – function electronic board – drive system electronic board circuit (orange cables)
14	Software error	Replace the drive system electronic board

(*) Flashing of led (A) of the drive system electronic board (B).

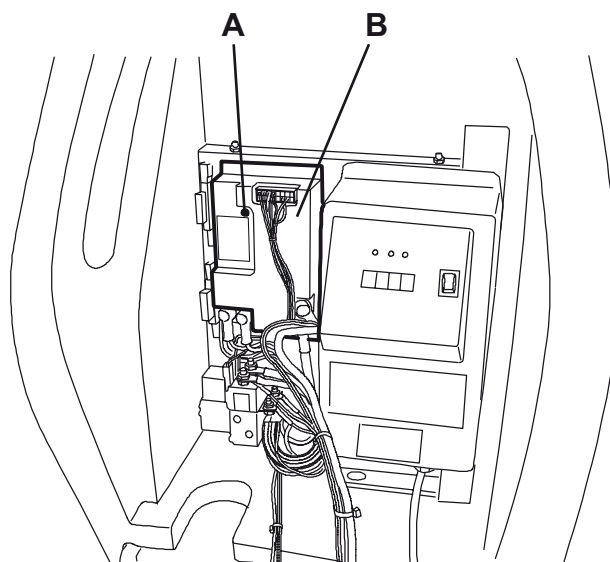

S301565

OTHER SYSTEM

OTHER SYSTEM

SCREW AND NUT TIGHTENING CHECK (All models)

1. Drive the machine to the appointed disposal area, and empty the recovery water tank (21) with the hose (16).
2. Place the machine on a hoisting system (if available).
Otherwise, drive the machine on a level floor.
3.
 - (For **BA 451D**, **BA 531D**, **BA 551D**, **BA 551CD**, **BA 611D**) Turn the ignition key (80) to "0".
 - (For **BA 451**, **BA 531**, **BA 551**) Turn off the switches (71) and (73).
 - (For **CA 451**, **CA 531**, **CA 551**) Disconnect the power supply cable (59) from the electrical mains.
4. (For **CA 451**, **CA 531**, **CA 551**) Open the recovery water tank cover (22). Remove the retaining plate (61) of the tank (40).
5. Grasp the handle (41) and carefully lift the tank (40).
6. Check:
 - Tightening of mounting screws and nuts;
 - Correct position of fasteners;
 - Visible faults in the components;
 - Leaks of fluids.
7. Carefully lower the tank (40).
8. (For **CA 451**, **CA 531**, **CA 551**) Install the retaining plate (61).

**WARNING!**

(For CA 451, CA 531, CA 551) When the maintenance/repair procedure is completed, the tank (40) must always be locked with the plate (61).

9. Remove the machine from the hoisting system.

ELECTRICAL SYSTEM**ELECTRICAL SYSTEM****MACHINE WORKING HOUR CHECK (For BA 451, BA 451D, BA 531, BA 531D, BA 551, BA 551D, BA 551CD, BA 611D, equipped with optional hour counter)**

1. (For **BA 451D, BA 531D, BA 551D, BA 551CD, BA 611D**) Turn the ignition key (80) to "1".
2. Press the vacuum system switch (73) and read on the hour counter (79) the total number of working hours (scrubbing/drying) performed by the machine.
3. Turn off the vacuum system by pressing the switch (73).
4. (For **BA 451D, BA 531D, BA 551D, BA 551CD, BA 611D**) Turn the ignition key (80) to "0".

MACHINE WORKING HOUR CHECK (For CA 451, CA 531, CA 551, equipped with optional hour counter)

1. Connect the power supply cable (59) to the electrical mains.
2. Press the vacuum system switch (63) and read on the hour counter (79) the total number of working hours (scrubbing/drying) performed by the machine.
3. Turn off the vacuum system by pressing the switch (63).
4. Disconnect the power supply cable (59) from the electrical mains and place it on the holder (50).

POWER SUPPLY CABLE CHECK (For CA 451, CA 531, CA 551)

Carefully check the power supply cable and the relevant plug for wear, cuts, cracks or other damages. If the power supply cable or the relevant plug is damaged, replace them with original spare parts.

BATTERY CHARGE AND MAINTENANCE (For BA 451, BA 451D, BA 531, BA 531D, BA 551, BA 551D, BA 551CD, BA 611D)

See the User Manual.

ELECTRICAL SYSTEM

BATTERY DISASSEMBLY/ASSEMBLY (For BA 451, BA 451D; BA 531, BA 531D, BA 551, BA 551D, BA 551CD, BA 611D)

Disassembly

1. If the tank (21) contains recovery water:
 - Drive the machine to the appointed recovery water disposal area.
 - (For **BA 451D, BA 531D, BA 551D, BA 551CD, BA 611D**) Turn the ignition key (80) to "0".
 - (For **BA 451, BA 531, BA 551**) Turn off the switches (71) and (73).
 - Empty the recovery water tank (21) with the hose (16).
2. Drive the machine on a level floor.
3. - (For **BA 451D, BA 531D, BA 551D, BA 551CD, BA 611D**) Turn the ignition key (80) to "0".
- (For **BA 451, BA 531, BA 551**) Turn off the switches (71) and (73).
4. Disconnect the battery connector (12).
5. Grasp the handle (41) and carefully lift the tank (40).
6. Disconnect the cables (A) from the battery terminals.
7. Remove the battery shims, if present.
8. Carefully remove the batteries (B).

Assembly

9. Assemble the batteries in the reverse order of disassembly, referring to the installation diagram (C), and note the following:
 - Set the machine according to the type of batteries installed (WET or GEL) as shown in the relevant paragraph.

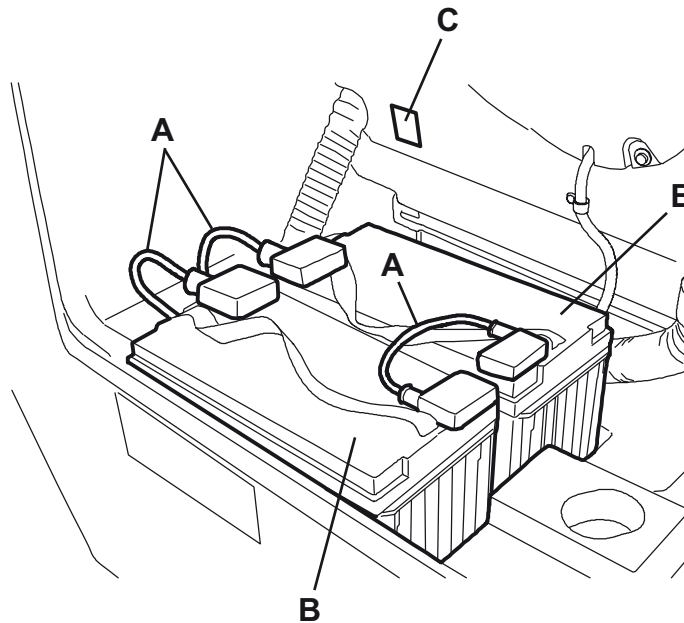

S301566

ELECTRICAL SYSTEM**BATTERY TYPE SETTING (WET OR GEL) (For BA 451, BA 531, BA 551)**

Set the electronic board of the machine and of the battery charger (if equipped) according to the type of batteries installed (WET or GEL) as shown below:

Machine setting

1. Press the switch (71) or (73) and pay attention to the following in the very first seconds of machine operation:
 - If the green warning led (81a) is flashing, the machine is set to GEL.
 - If the red warning led (81c) is flashing, the machine is set to WET.
2. If the setting is to be changed, perform the following procedure.
3. Make sure that the switches (71) and (73) are turned off.
4. Press and hold the switches (71) and (73) at the same time.
5. Release the switches (71) and (73) at least 8 seconds after starting the machine.
6. Within three seconds, press the switch (73) again for a few seconds and check that the warning led for the required setting is flashing (as shown in step 1).

Battery charger setting (if equipped)

7. Remove the battery charger data inspection window screws (A).
8. Remove the window (B).
9. Turn the battery charger selector (C) to WET position for lead batteries, or to GEL position for gel batteries.
10. Install the window (B) and tighten the screws (A).

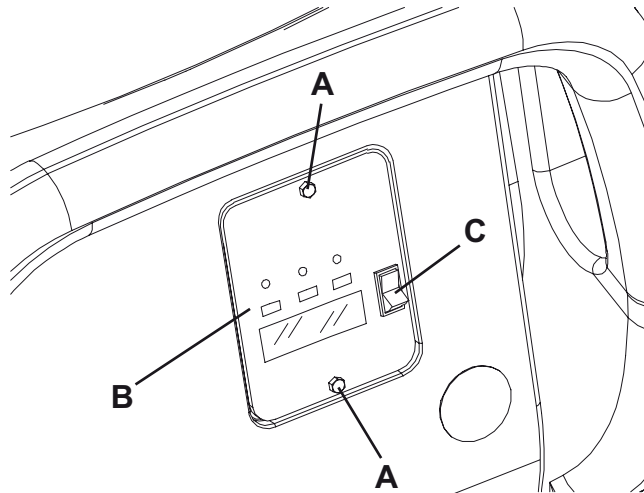

S301567

ELECTRICAL SYSTEM

BATTERY TYPE SETTING (WET OR GEL) (For BA 451D, BA 531D, BA 551D, BA 551CD, BA 611D)

Set the electronic board of the machine and of the battery charger (if equipped) according to the type of batteries installed (WET or GEL) as shown below:

Machine setting

1. Turn the ignition key (80) to "I" position and pay attention to the following in the very first seconds of machine operation:
 - If the green warning led (81a) is flashing, the machine is set to GEL.
 - If the red warning led (81c) is flashing, the machine is set to WET.
2. If the setting is to be changed, perform the following procedure.
3. Turn off the machine by turning the ignition key (80) to "0".
4. Press and hold the switches (71) and (73) at the same time, then turn the ignition key (80) to "I".
5. Release the switches (71) and (73) at least 8 seconds after starting the machine.
6. Within three seconds, press the switch (73) again for a few seconds and check that the warning led for the required setting is flashing (as shown in step 1).

Battery charger setting (if equipped)

7. Remove the battery charger data inspection window screws (A).
8. Remove the window (B).
9. Turn the battery charger selector (C) to WET position for lead batteries, or to GEL position for gel batteries.
10. Install the window (B) and tighten the screws (A).

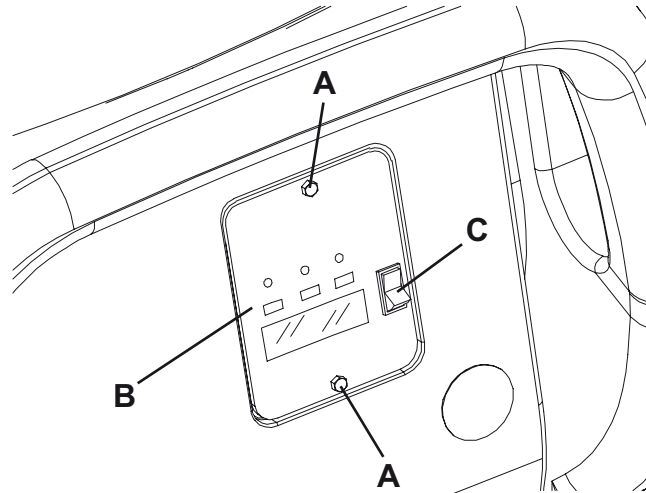

S301567

ELECTRICAL SYSTEM

FUSE CHECK/REPLACEMENT (For BA 451, BA 451D, BA 531, BA 531D, BA 551, BA 551D, BA 551CD, BA 611D)

1. Disconnect the battery connector (12).
2. Move aside the recovery water drain hose (16).
3. Remove the battery charger cable (I), if equipped, from the cable holder (J).
4. Remove the screws (A) and carefully move aside the panel (B) by disengaging the grommet (K) from its housing on the panel (B).
5. Check/replace the following fuses:
 - (C) - F1 fuse, deck: (40 A)
 - (D) - F2 fuse, vacuum system: (30 A)
 - (E) - F3 fuse, drive system: (30 A) (*)
 - (F) - F4 fuse, signal circuits: (3 A)
 - (G) - F5 fuse, brush/pad-holder release: (20 A) (*)
 - (H) - F6 fuse, pumps: (3 A) (*)

(*) Only for **BA 451D, BA 531D, BA 551D, BA 551CD, BA 611D**

6. Perform steps 1 to 4 in the reverse order.

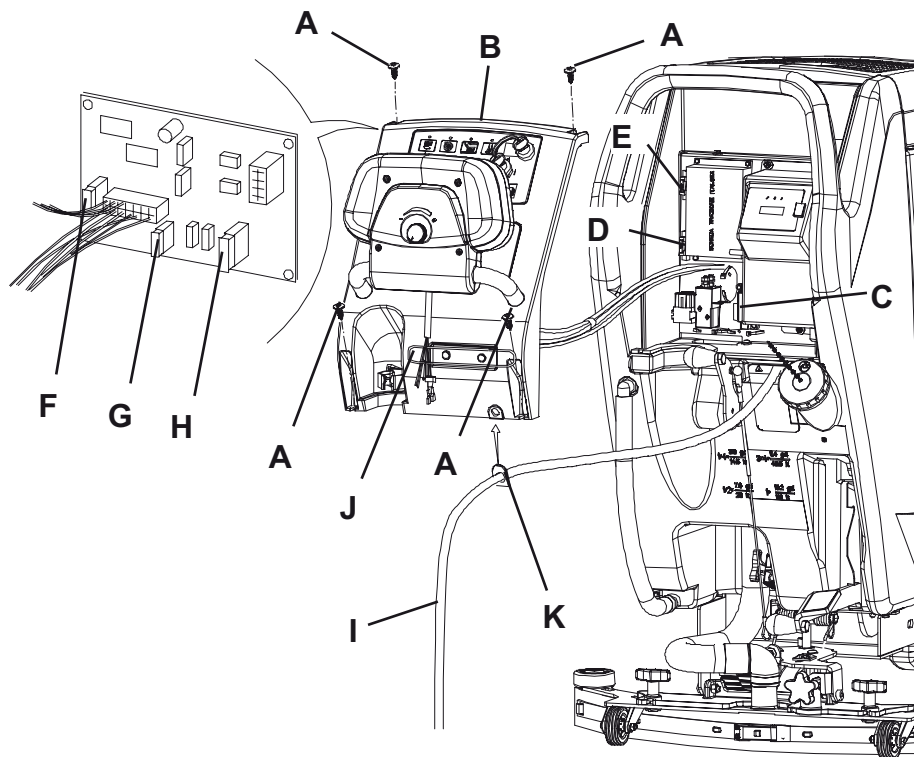

S301569

ELECTRICAL SYSTEM

FUSE CHECK/REPLACEMENT (For CA 431, CA 531, CA 551)

1. Disconnect the power supply cable (59) from the electrical mains but do not place it on the holder (60).
2. If the power supply cable (59) is on the holder (60), remove it.
3. Move aside the recovery water drain hose (16).
4. Remove the screws (A) and carefully move the panel (B).
5. Check/replace the following fuse:
 - (C) - FL1 fuse, electronic board: (1 A)
6. Perform steps 2 to 4 in the reverse order.

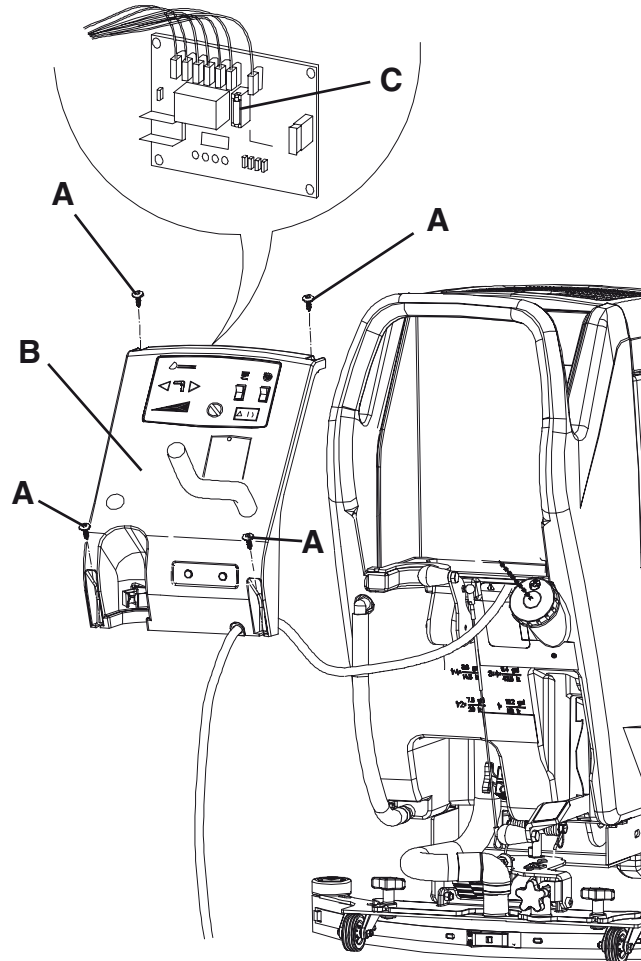

S301570

ELECTRICAL SYSTEM**BRUSH MOTOR ELECTROMAGNETIC SWITCH DISASSEMBLY/ASSEMBLY (For BA 451, BA 451D, BA 531, BA 531D, BA 551, BA 551D, BA 551CD, BA 611D)****Disassembly**

1. Disconnect the battery connector (12).
2. Move aside the recovery water drain hose (16).
3. Remove the battery charger cable (6), if equipped, from the cable holder (7).
4. Remove the screws (A) and carefully move aside the panel (B) by disengaging the cable grommet (C) from its housing on the panel (B).
5. Disconnect the connectors (D), (E), (F), and remove the panel (B).
6. Disconnect the terminals (G) and (H) from the electromagnetic switch (J). Disconnect also the terminals (I), which are present only on the models with drive system.
7. Remove the screws (K) and move the electrical panel (L) by disengaging it from the lower fastener (M).
8. Remove the screws (N) on the rear side of the electrical panel (L), then remove the electromagnetic switch (J).

Assembly

9. Assemble the components in the reverse order of disassembly.

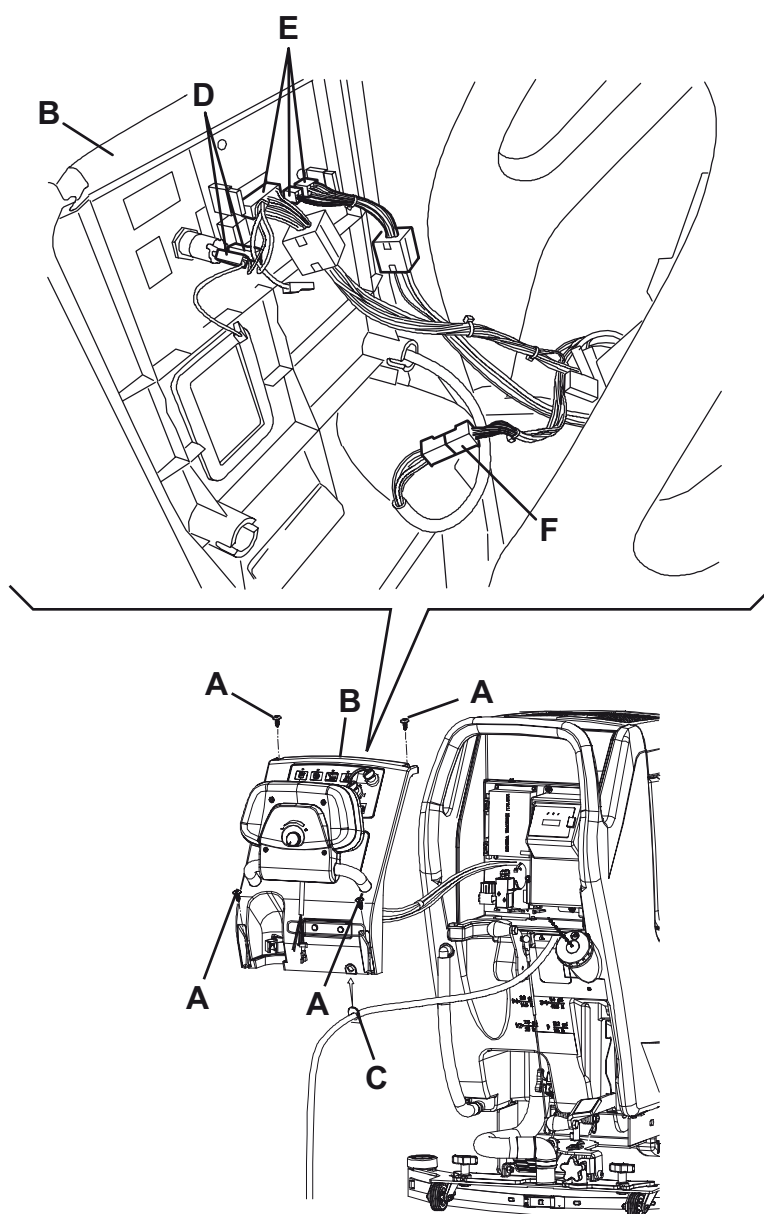

S301571

ELECTRICAL SYSTEM

BRUSH MOTOR ELECTROMAGNETIC SWITCH DISASSEMBLY/ASSEMBLY (For BA 451, BA 451D, BA 531, BA 531D, BA 551, BA 551D, BA 551CD, BA 611D) (Continues)

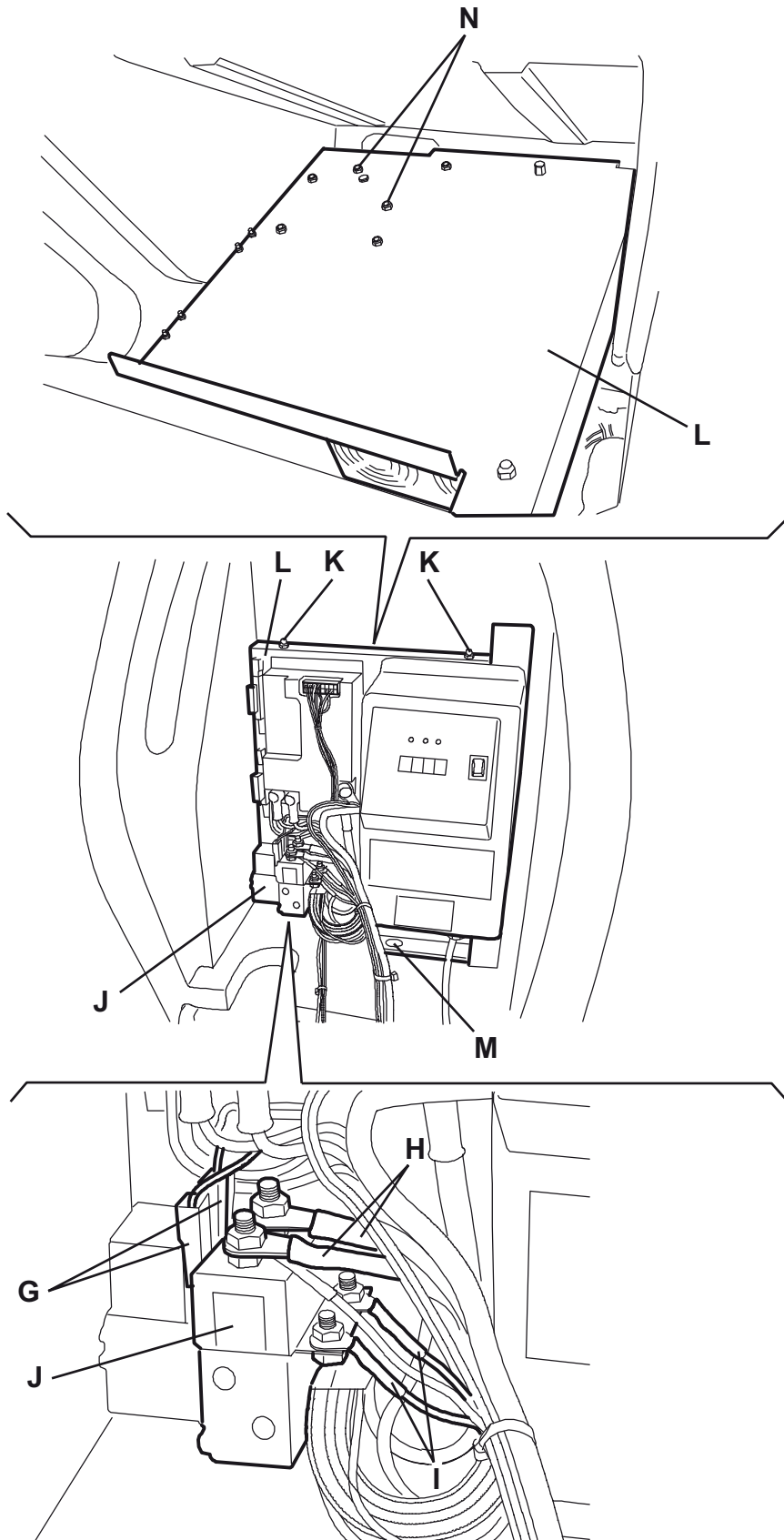

S301572

ELECTRICAL SYSTEM**DRIVE SYSTEM ELECTRONIC BOARD DISASSEMBLY/ASSEMBLY (For BA 451D, BA 531D, BA 551D, BA 551CD, BA 611D)****Disassembly**

1. Disconnect the battery connector (12).
2. Move aside the recovery water drain hose (16).
3. Remove the battery charger cable (6), if equipped, from the cable holder (7).
4. Remove the screws (A) and carefully move aside the panel (B) by disengaging the cable grommet (C) from its housing on the panel (B).
5. Disconnect the connectors (D), (E), (F), and remove the panel (B).
6. Disconnect the connectors (G) of the drive system electronic board (H).
7. Remove the screws (I) and move the electrical panel (J) by disengaging it from the lower fastener (K).
8. Remove the screws (L) on the rear side of the electrical panel (J), then remove the drive system electronic board (H).

Assembly

9. Assemble the components in the reverse order of disassembly.

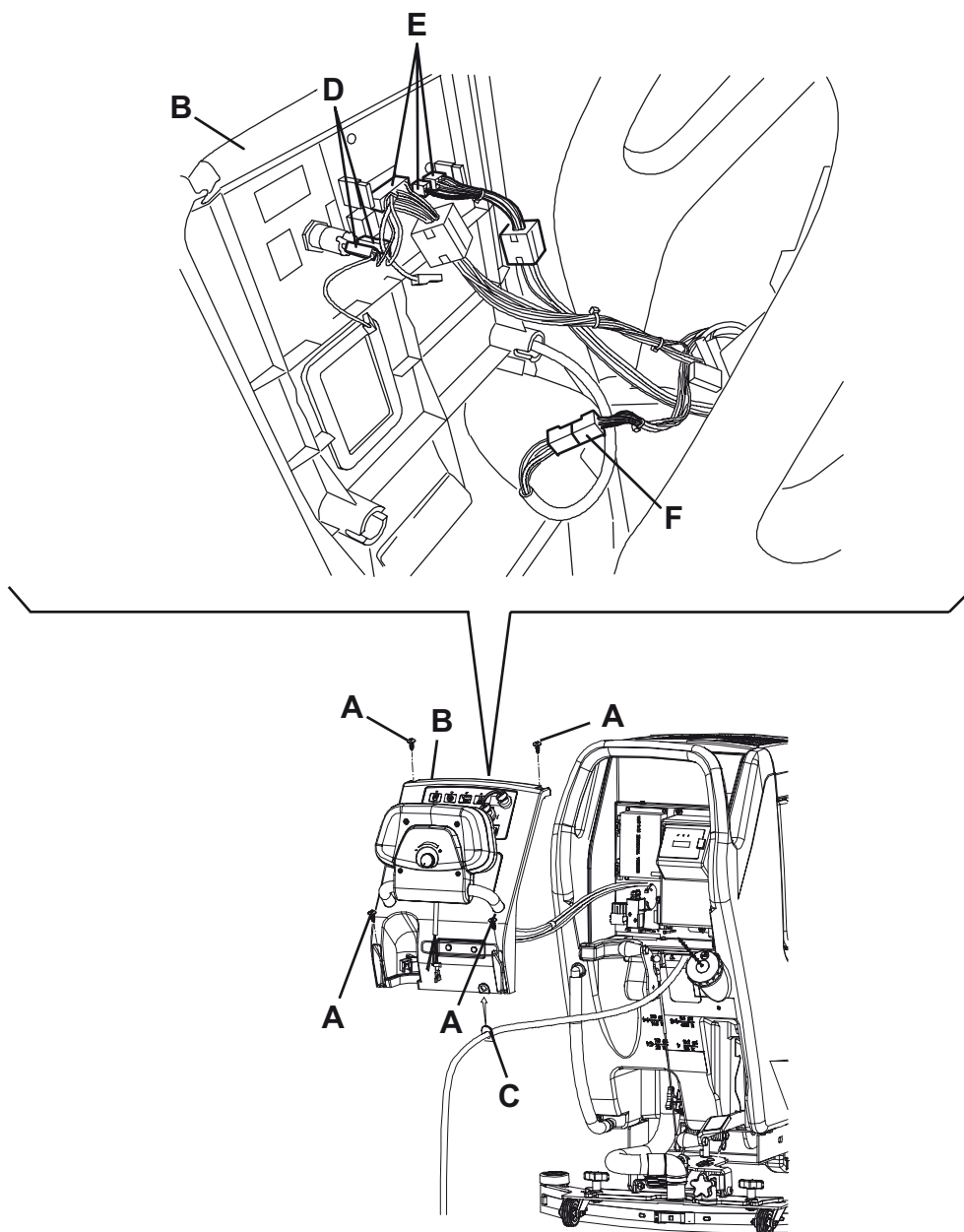

S301573

ELECTRICAL SYSTEM

DRIVE SYSTEM ELECTRONIC BOARD DISASSEMBLY/ASSEMBLY (For BA 451D, BA 531D, BA 551D, BA 551CD, BA 611D) (Continues)

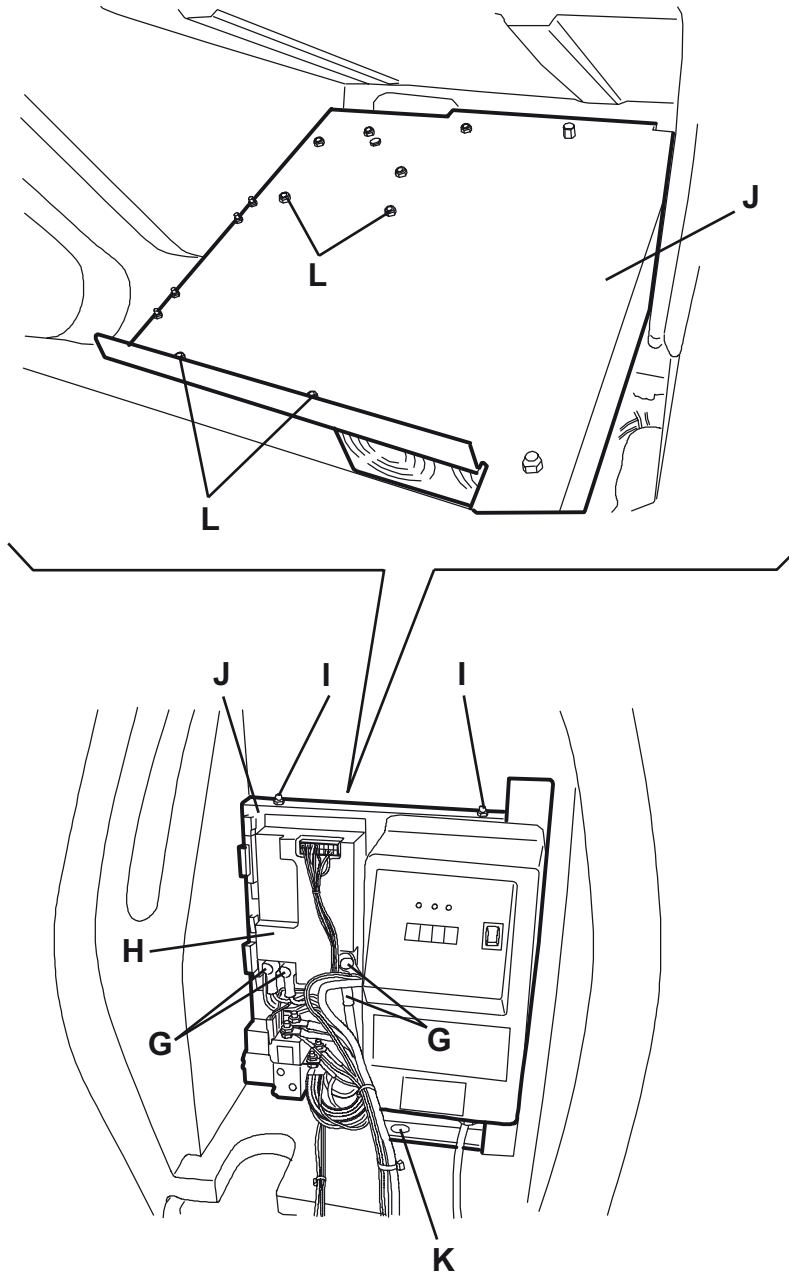

S301574

ELECTRICAL SYSTEM

FUNCTION ELECTRONIC BOARD DISASSEMBLY/ASSEMBLY (For BA 451, BA 451D, BA 531, BA 531D, BA 551, BA 551D, BA 551CD, BA 611D)

Disassembly

1. Disconnect the battery connector (12).
2. Move aside the recovery water drain hose (16).
3. Remove the battery charger cable (6), if equipped, from the cable holder (7).
4. Remove the screws (A) and carefully move aside the panel (B) by disengaging the cable grommet (C) from its housing on the panel (B).
5. Disconnect the connectors (D), (E), (F), and remove the panel (B).
6. On the panel, remove the screws (G), then remove the function electronic board (H).

Assembly

7. Assemble the components in the reverse order of disassembly.

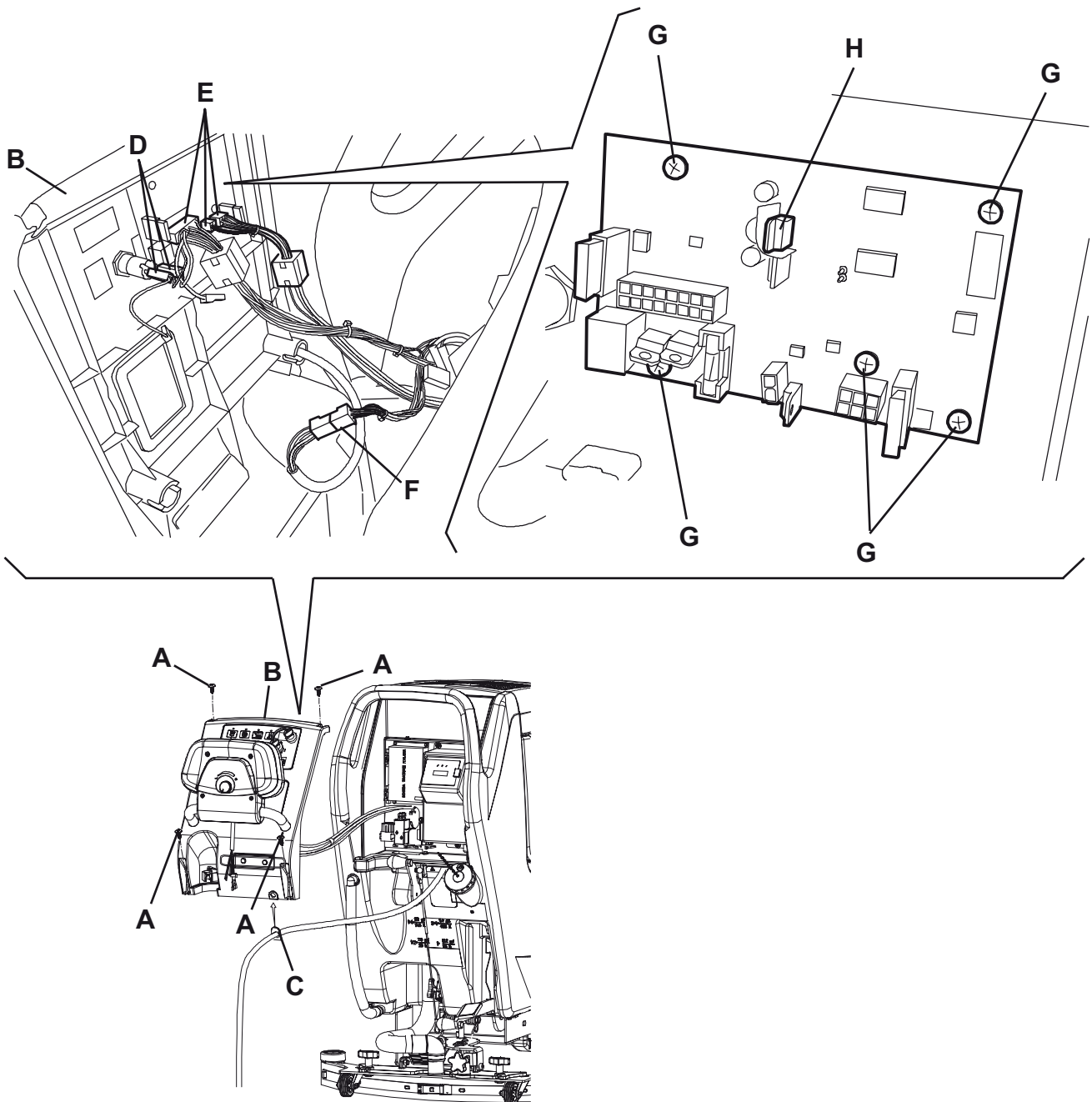

S301575

ELECTRICAL SYSTEM

WATER FLOW CONTROL ELECTRONIC BOARD DISASSEMBLY/ASSEMBLY (For CA 451, CA 531, CA 551)

Disassembly

1. Disconnect the power supply cable (59) from the electrical mains but do not place it on the holder (60).
2. If the power supply cable (59) is on the holder (60), remove it.
3. Move aside the recovery water drain hose (16).
4. Remove the screws (A) and carefully move the panel (B).
5. If necessary, mark the position of the connections (C) of the water flow control electronic board (D) to reinstall them correctly (if necessary, refer to the wiring diagram to check the connection positions).
6. Disconnect the connectors (C) of the water flow control electronic board (D).
7. Remove the screws (E), then remove the water flow control electronic board (D).

Assembly

8. Assemble the components in the reverse order of disassembly.

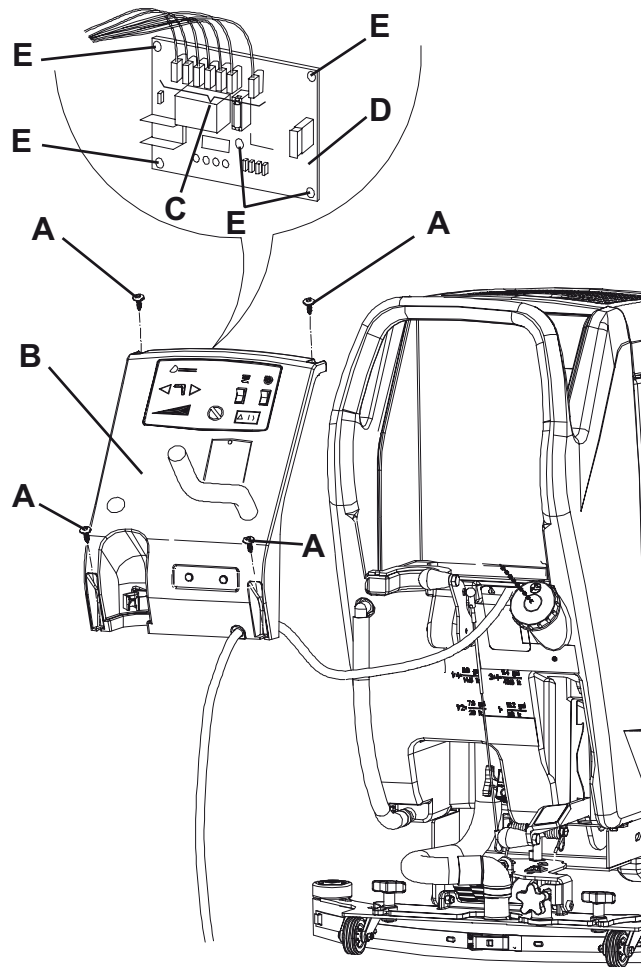

S301576

ELECTRICAL SYSTEM

TROUBLESHOOTING

See the previous chapters related to the use of the electrical system.

Other possible causes:

1. The batteries are discharged or the connections are not efficient (charge the batteries or clean the connections).
2. The batteries are broken (check the battery no-load voltage).



NOTE

In the machines equipped with on-board battery charger, a fault in the battery charger and relevant connections can affect the machine operation.

3. The battery charger is broken (replace) (only for machine equipped with on-board battery charger).
4. There is an open in the fuses (replace).
5. The harness is cut, pressed or short-circuited (repair).
6. Error codes indicated by led (81a - 81b - 81c):

Flashes	Meaning	Action
Green, yellow and red LED flashing simultaneously.	Problem related to brush motor overload.	Perform checks shown in BRUSH MOTOR ELECTRICAL INPUT CHECK.
		If check results are negative, check the F1 fuse for integrity and its nut tightness.
Red LED flashing.	The batteries are discharged.	Charge the batteries.
		If the problem persists, replace them.

ELECTRICAL SYSTEM

COMPONENT LAYOUT (For BA 451, BA 531, BA 551)

Key:

BAT	24 V battery
C1	Battery connector
C2	Battery charger connector
CH	Battery charger (optional)
CS	Deck connector
EB1	Function electronic board
ES1	Brush electromagnetic switches
ES2	Vacuum system relay
EV1	Water solenoid valve
F1	Deck fuse
F2	Vacuum system fuse
F4	Signal circuit fuse
HM	Hour counter (optional)
M1	Brush/pad-holder motor
M2	Vacuum system motor



NOTE
Figure showing BA 551

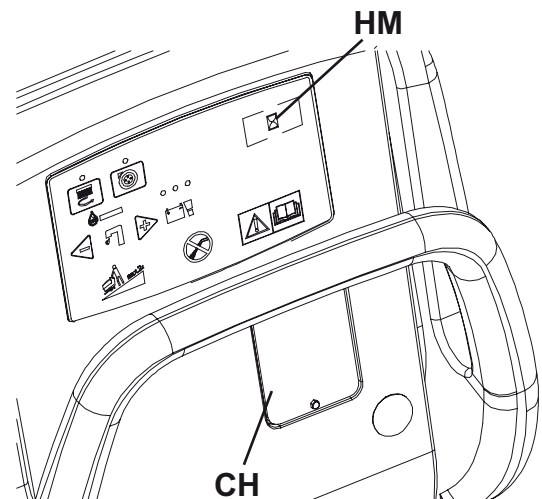
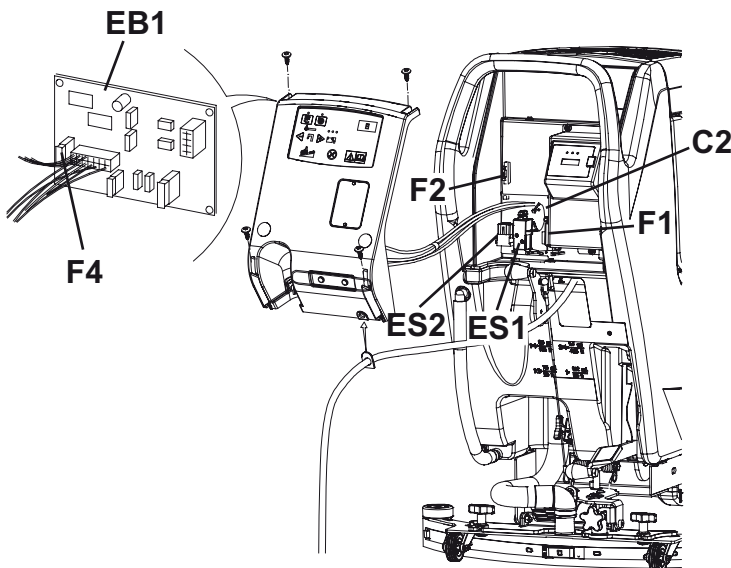
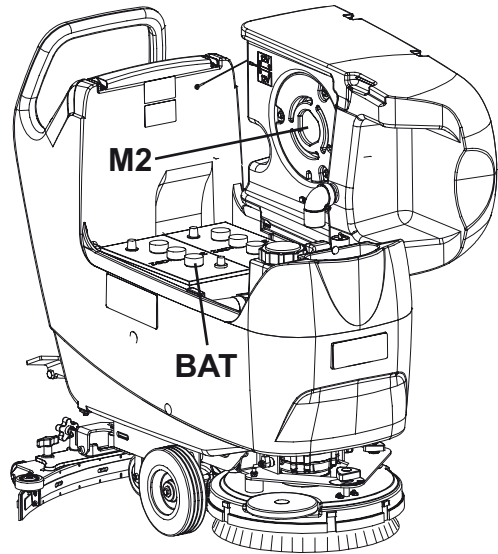
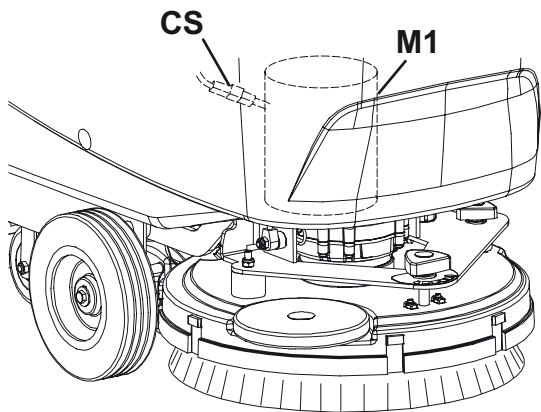
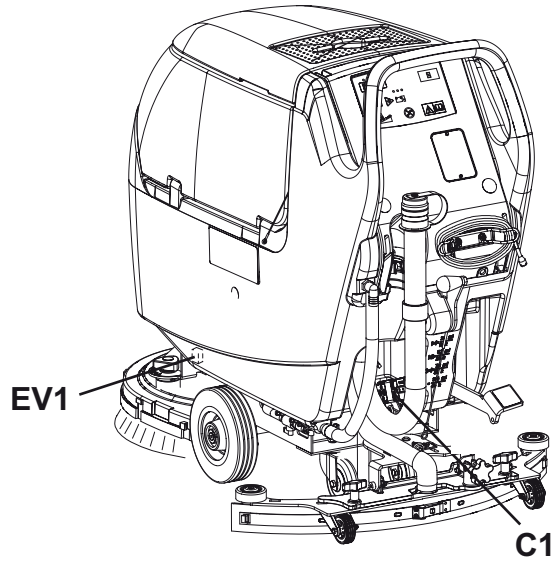

S301577

ELECTRICAL SYSTEM

WIRING DIAGRAM (For BA 451, BA 531, BA 551)

Key:

BAT	24 V battery
C1	Battery connector
C2	Battery charger connector
CH	Battery charger (optional)
CS	Deck connector
EB1	Function electronic board
ES1	Brush electromagnetic switches
ES2	Vacuum system relay
EV1	Water solenoid valve
F1	Deck fuse
F2	Vacuum system fuse
F4	Signal circuit fuse
HM	Hour counter (optional)
M1	Brush/pad-holder motor
M2	Vacuum system motor

Colour codes:

BK	Black
BU	Blue
BN	Brown
GN	Green
GY	Grey
OG	Orange
PK	Pink
RD	Red
VT	Violet
WH	White
YE	Yellow

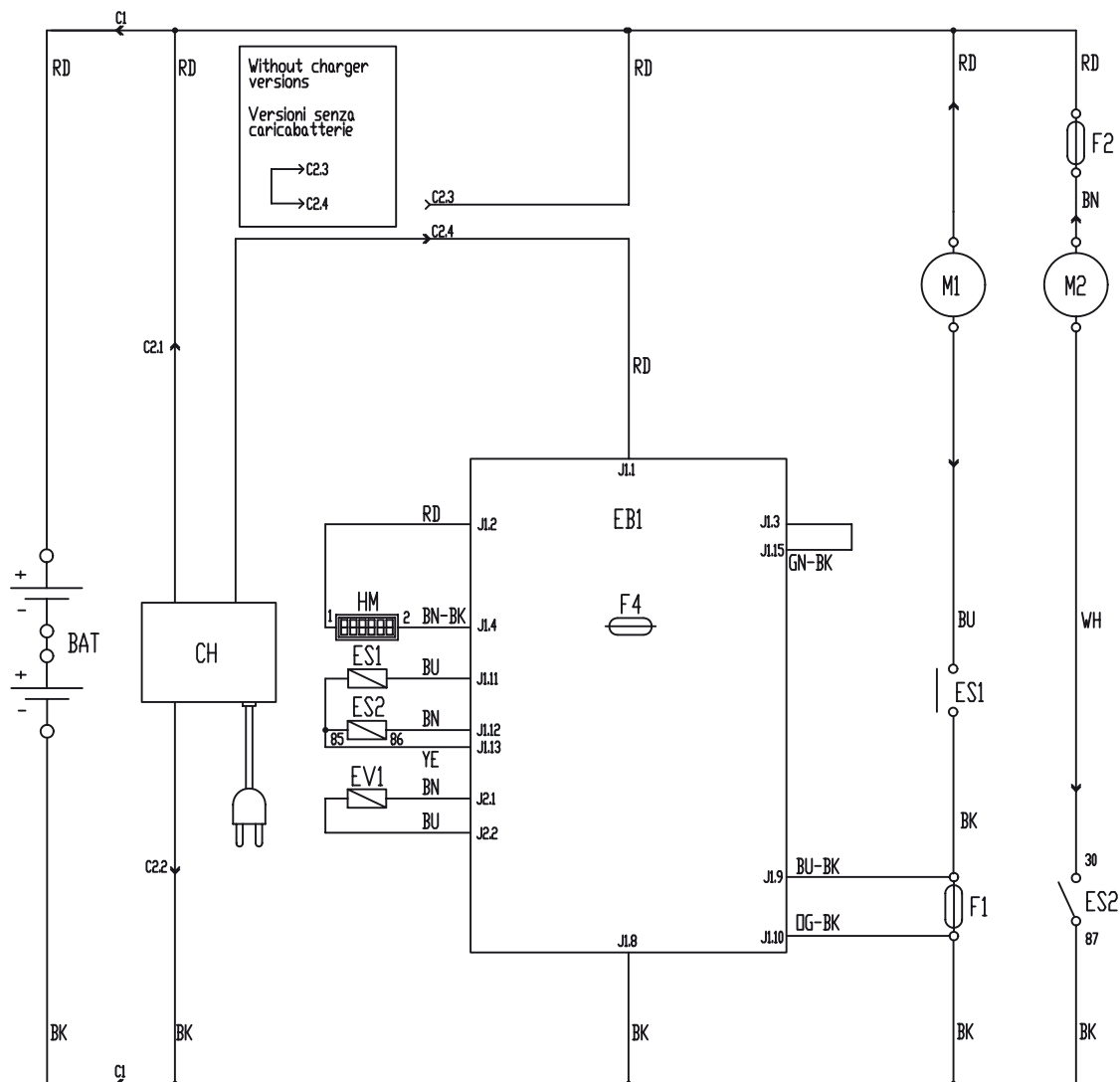

S301578

ELECTRICAL SYSTEM

COMPONENT LAYOUT (For BA 451D, BA 531D, BA 551D, BA 551CD, BA 611D)

Key:

BAT	24 V battery
C1	Battery connector
C2	Battery charger connector
CH	Battery charger (optional)
CSC	Cylindrical brush deck secondary connector
EB1	Function electronic board
EB2	Drive system electronic board
ES1	Brush electromagnetic switches
ES2	Vacuum system relay
EV1	Detergent solenoid valve (optional)
F1	Deck fuse
F2	Vacuum system fuse
F3	Drive system fuse
F4	Signal circuit fuse
F5	Brush/pad-holder release fuse
F6	Pump fuse
HM	Hour counter (optional)
K1	Ignition key
M1	Brush/pad-holder motor
M2	Vacuum system motor
M3	Drive system motor
M4	Water pump (optional)
M5	Detergent pump (optional)
RV1	Speed potentiometer
RV2	Maximum speed potentiometer
SW1	Drive system/brush enabling microswitch

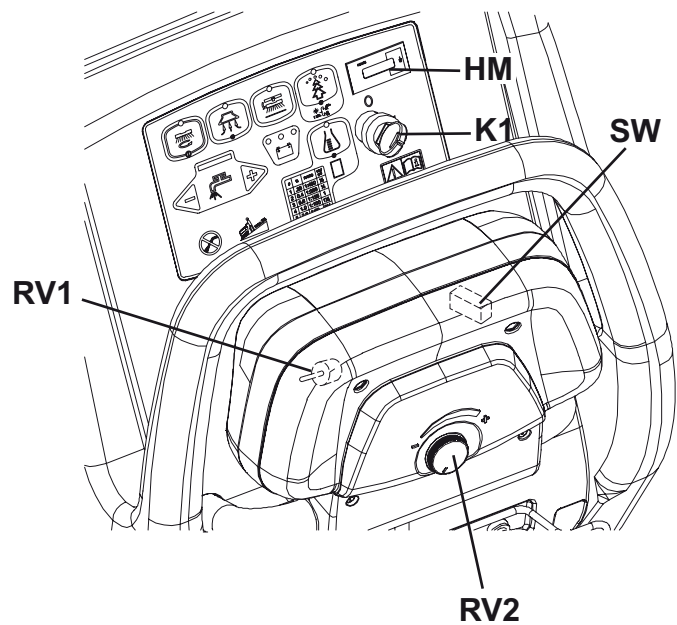
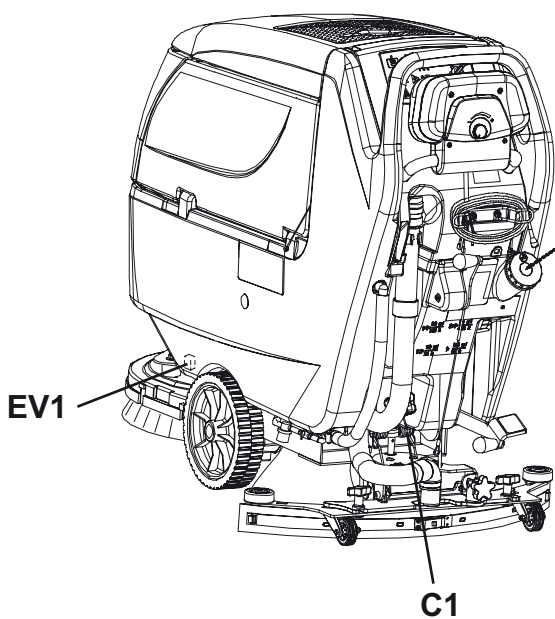

S301579

ELECTRICAL SYSTEM

COMPONENT LAYOUT (For BA 451D, BA 531D, BA 551D, BA 551CD, BA 611D) (Continues)

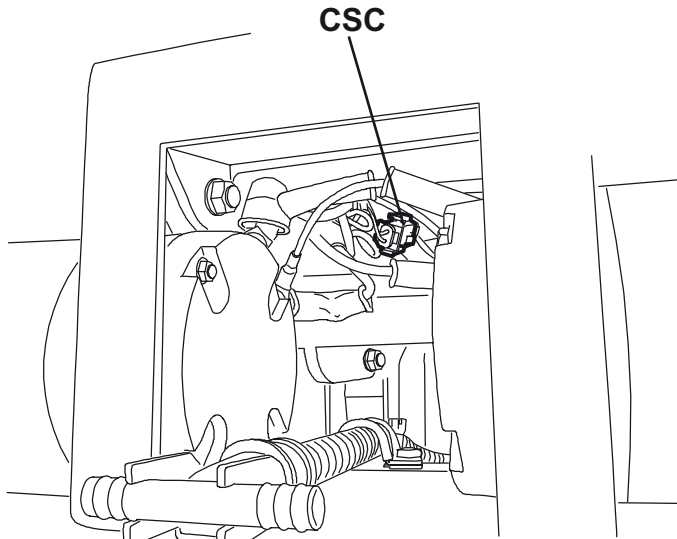
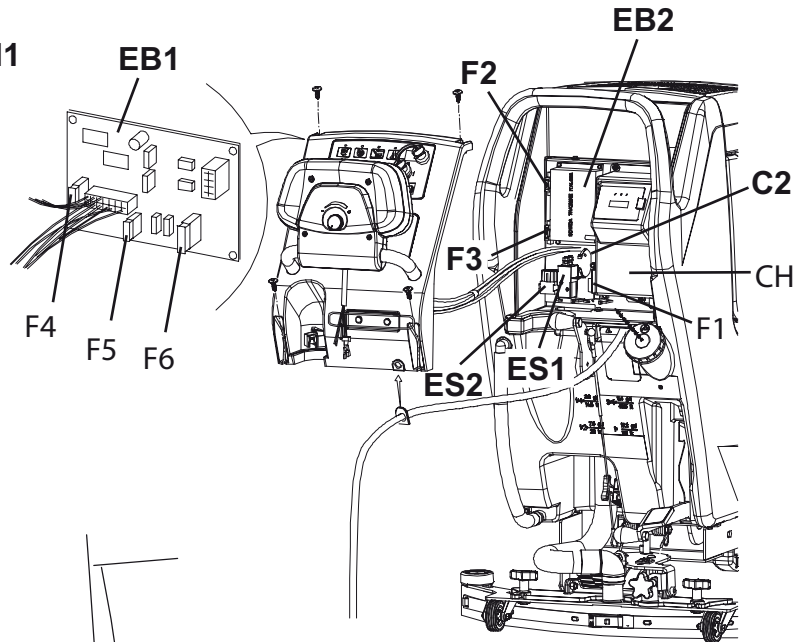
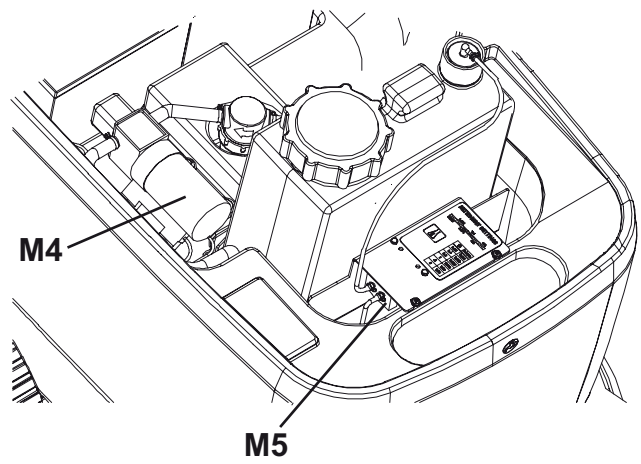
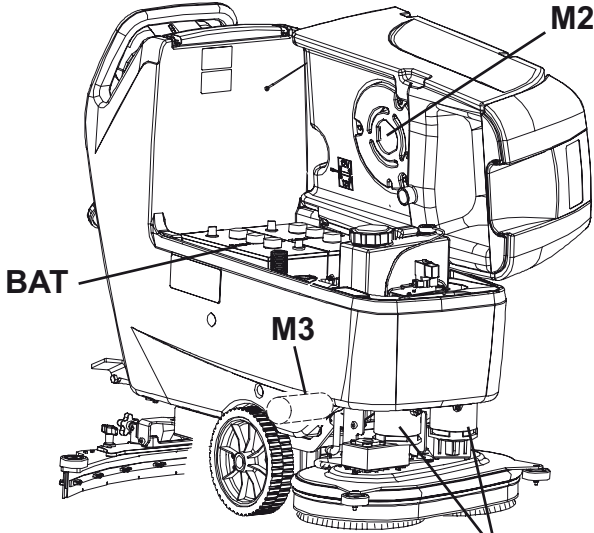

S301580

ELECTRICAL SYSTEM

WIRING DIAGRAM (For BA 451D, BA 531D, BA 551D, BA 551CD, BA 611D)

Key:

BAT	24 V battery
C1	Battery connector
C2	Battery charger connector
CH	Battery charger (optional)
CS	Cylindrical brush deck secondary connector
EB1	Function electronic board
EB2	Drive system electronic board
ES1	Brush electromagnetic switches
ES2	Vacuum system relay
EV1	Detergent solenoid valve (optional)
F1	Deck fuse
F2	Vacuum system fuse
F3	Drive system fuse
F4	Signal circuit fuse
F5	Brush/pad-holder release fuse
F6	Pump fuse
HM	Hour counter (optional)
K1	Ignition key
M1	Brush/pad-holder motor
M2	Vacuum system motor
M3	Drive system motor
M4	Water pump (optional)
M5	Detergent pump (optional)
RV1	Speed potentiometer
RV2	Maximum speed potentiometer
SW1	Drive system/brush enabling microswitch

- (*) Only for machine with wheel diameter of 9.8 in (250 mm)
- (**) Only for machines with cylindrical brush deck
- (***) Only for machines without on-board battery charger

Colour codes:

BK	Black
BU	Blue
BN	Brown
GN	Green
GY	Grey
OG	Orange
PK	Pink
RD	Red
VT	Violet
WH	White
YE	Yellow

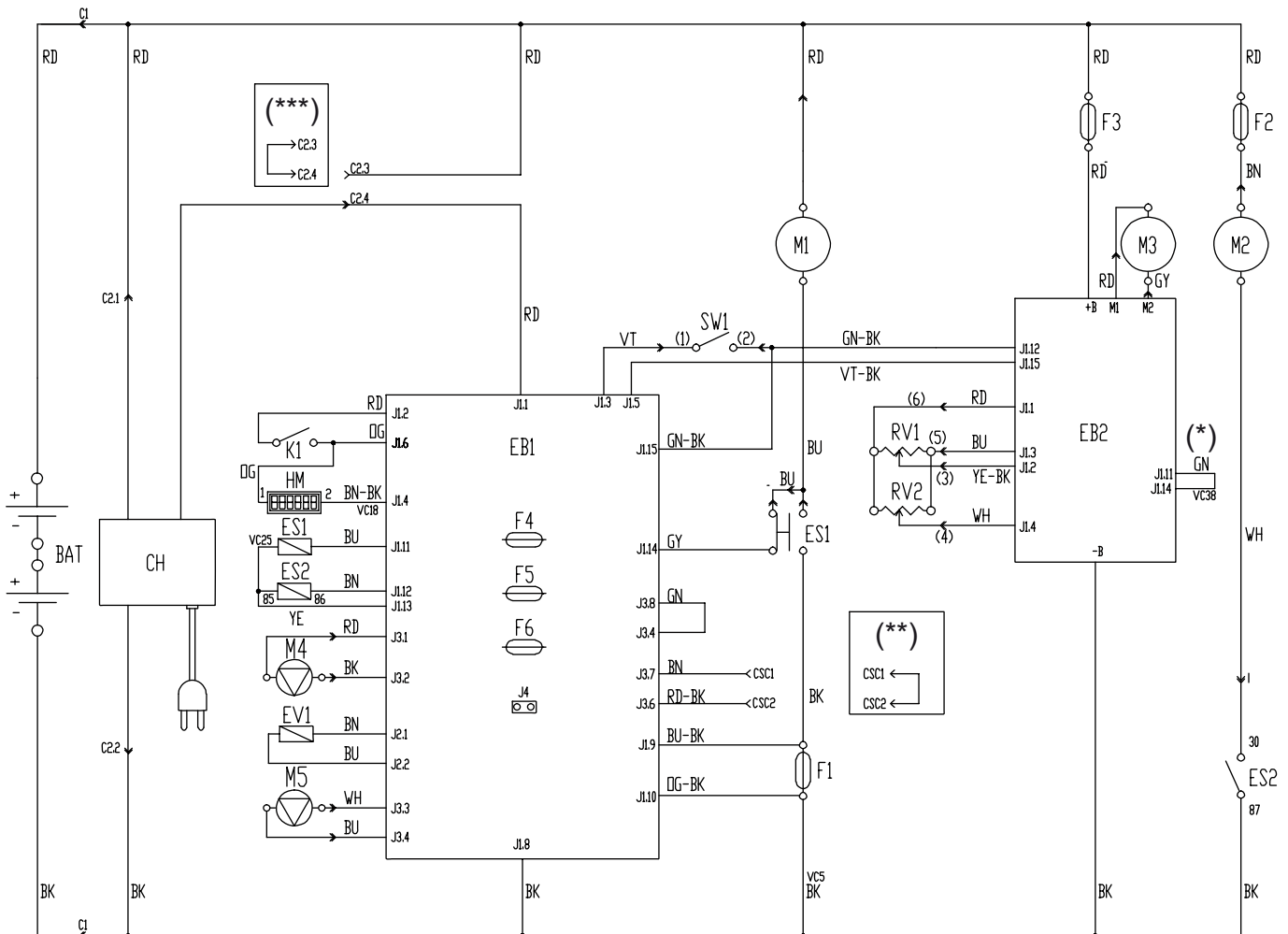

S3113332

ELECTRICAL SYSTEM

COMPONENT LAYOUT (For CA 451, CA 531, CA 551)

Key:

C1	Filtering condenser
EB1	Water flow check electronic board
EV1	Water solenoid valve
FL1	Electronic board fuse
FR	Machine frame
HM	Hour counter (optional)
HS	Grounding screw
M1	Brush/pad-holder motor
M2	Vacuum system motor
PL1	Plug
SW1	Brush/pad-holder switch
SW2	Vacuum system switch



NOTE
Figure showing CA 551

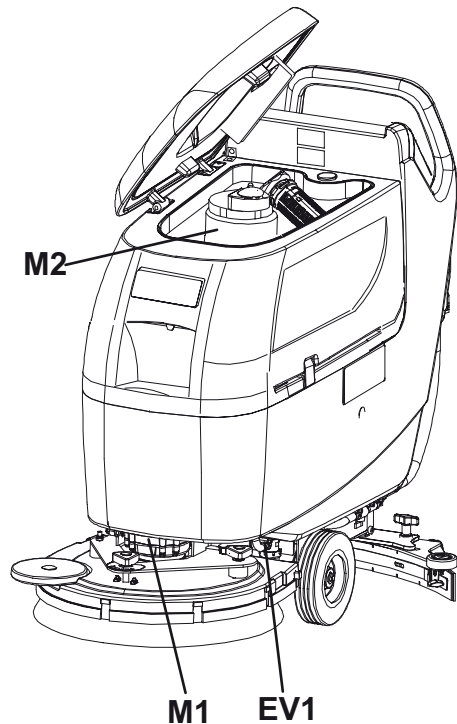
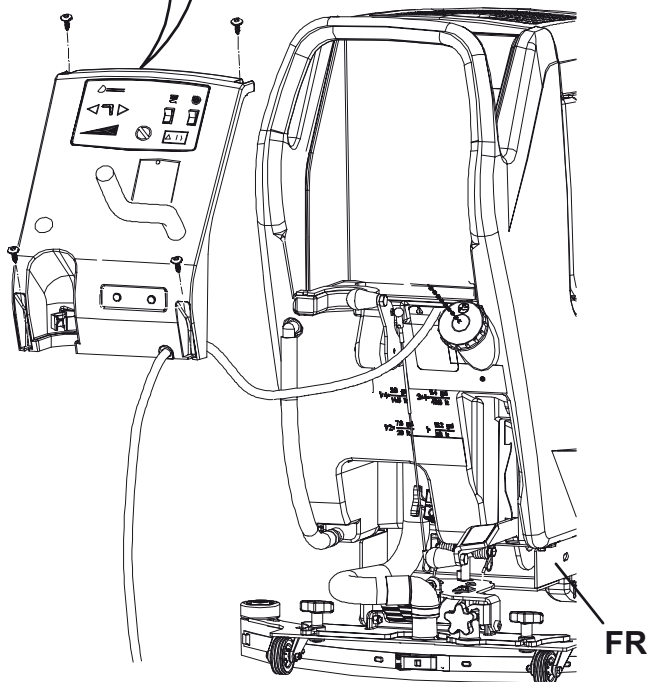
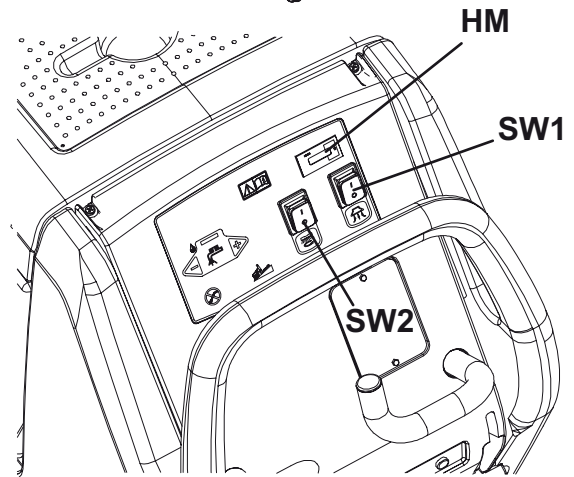
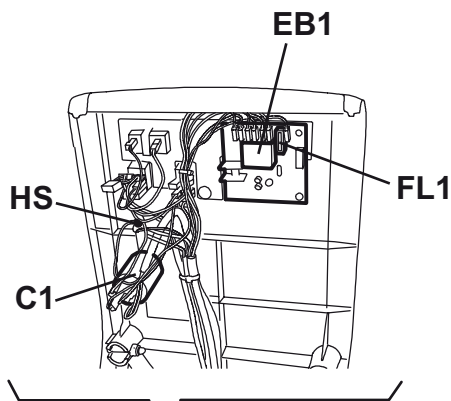
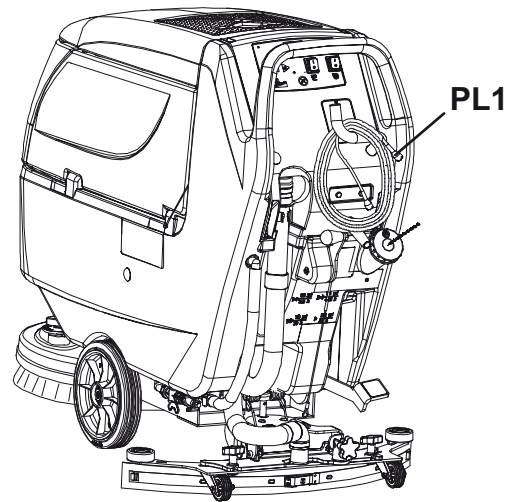

S301582

ELECTRICAL SYSTEM

WIRING DIAGRAM (For CA 451, CA 531, CA 551)

Legenda:

C1	Filtering condenser
EB1	Water flow check electronic board
EV1	Water solenoid valve
FL1	Electronic board fuse
FR	Machine frame
HM	Hour counter (optional)
HS	Grounding screw
M1	Brush/pad-holder motor
M2	Vacuum system motor
PL1	Plug
SW1	Brush/pad-holder switch
SW2	Vacuum system switch

Colour codes:

BK	Black
BU	Blue
BN	Brown
GN	Green
GY	Grey
OG	Orange
PK	Pink
RD	Red
VT	Violet
WH	White
YE	Yellow

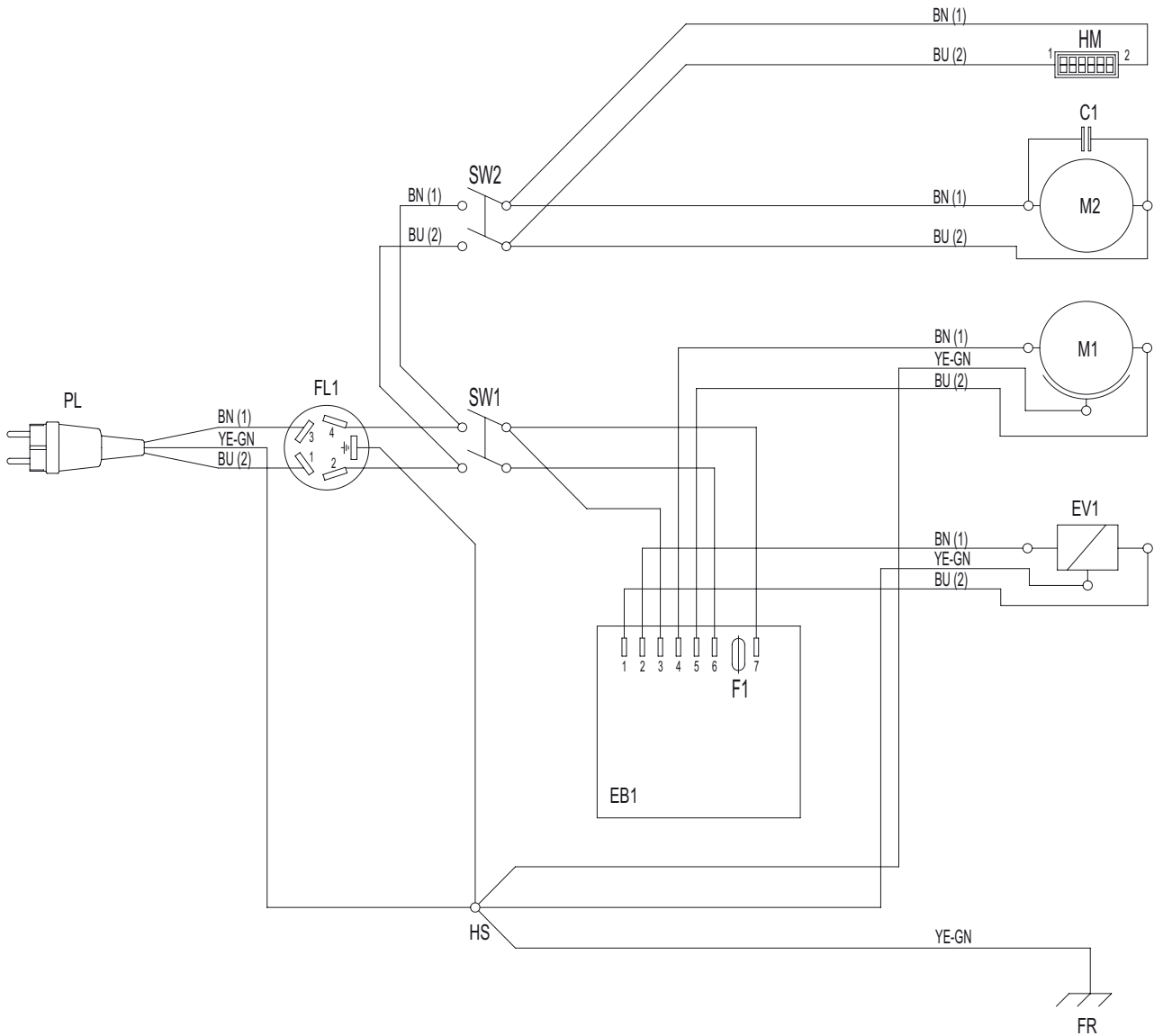

S301583

ELECTRICAL SYSTEM

EB1 ELECTRONIC BOARD CONNECTOR PINS (for BA 451, BA 451D, BA 531, BA 531D, BA 551, BA 551D, BA 551CD, BA 611D)

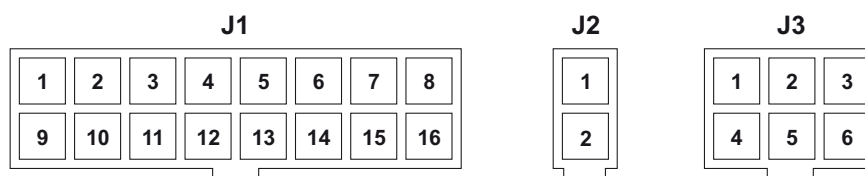

S301581

Electronic board for BA 451, BA 531, BA 551

Supplier Ref.	Ref. Rev. Spec.
7CFBA600	Till S/N 072115094
7CFBA606	current version

Electronic board for BA 451D, BA 531D, BA 551D, BA 551CD, BA 611D

Supplier Ref.	Ref. Rev. Spec.
7CFBA700	Till S/N 072014255
7CFBA706	current version

CONNECTORS (on B side card)

J1: MOLEX MINIFIT type 16 ways vertical

PIN	Description	Electronic board in/out	V ref.	Connected to
1	Electronic board power supply +	BOARD	24V always, with connected batteries	BAT
2	Ignition key circuit power supply	IN/OUT	24V always, with connected batteries	K1
3	Auxiliary signal power supply	OUT	24V always, with connected batteries	SW1 SW2
4	Hour counter power supply	OUT	0V with Vacuum function activated	HM
5	Drive system electronic board enabling	OUT	24V with key on "I"	EB2.J1.15
6	Return from ignition key	IN	24V with key on "I"	K1
7	-	-	-	-
8	Electronic board power supply -	IN	0V always, with connected batteries	BAT
9	Brush fuse voltage drop reading +	IN	0 ÷ 50mV nearly proportional to the current in brush motors	F1
10	Brush fuse voltage drop reading -	IN	0V always, with connected batteries	F1
11	Brush electromagnetic switch power supply -	OUT	0V with brush function activated	ES1
12	Vacuum system relay power supply -	OUT	0V with Vacuum function activated	ES2
13	Electromagnetic switch/relay power supply +	OUT	24V with key on "I"	ES1-ES2
14	Brush motor braking circuit	IN	24V with brush function deactivated	ES1.NC
15	Drive system/brush enabling (panel)	IN	24V with pressed paddle	SW1
16				-

ELECTRICAL SYSTEM**EB1 ELECTRONIC BOARD CONNECTOR PINS (for BA 451, BA 451D, BA 531, BA 531D, BA 551, BA 551D, BA 551CD, BA 611D) (continues)****J2: MOLEX MINIFIT type 2 ways vertical**

PIN	Description	Electronic board in/out	V ref.	Connected to
1	Solenoid valve power supply +	OUT	24V with key on "I"	EV1
2	Solenoid valve power supply -	OUT	0V pulsed, according to water flow setting, only with paddle pressed and brush function activated	EV1

J3: MOLEX MINIFIT type 6 ways vertical (only version CFBA706)

PIN	Description	Electronic board in/out	V ref.	Connected to
1	Water pump power supply +	OUT	24V with key on "I"	M4 (only for CFBA706)
2	Water pump power supply -	OUT	0V pulsed, according to water flow setting, only with paddle pressed and brush function activated	M4 (only for CFBA706)
3	Solution pump power supply +	OUT	24V with key on "I"	M5
4	Solution pump power supply -	OUT	0V pulsed as J3.2, when active squared wave with different frequencies according to the setting solution flow	M5
5	B-type deck configuration return	IN	24V always with cylindrical brush deck installed	CSC.2
6	Auxiliary power supply +	OUT	24V with key on "I"	CSC.1



We supply a full range of cleaning equipment for rental or purchase.

For more information, or a cleaning solution to suit your business, please get in touch –

For a more comprehensive product range, please visit our website.



Address

Berrington House,
Berrington Road,
Leamington Spa
CV31 1NB

Contact

t: 0845 33 77 695
f: 0845 33 78 695
e: info@c-ind.co.uk

www.crescentindustrial.co.uk